

A Novel Shaped Four Port MIMO Antenna for Wireless Communication

Sukla Basu

Department of Electronics and Communication Engineering,
Kalyani Government Engineering College, Kalyani, West Bengal, India
E-mail: sbasu1996@gmail.com

(Received 16 January 2022; Revised 5 February 2023; Accepted 4 March 2023; Available online 10 March 2023)

Abstract - This paper presents a compact novel shaped micro strip line fed four element Multiple Input Multiple Output (MIMO) antenna for wireless application at 2.4 GHz. Four vertically oriented identical rectangular patch antennas are used to form a hollow cylinder of rectangular cross section. The direction of radiation of each antenna is thus oriented at 90° with respect to its two adjacent antennas providing good isolation between adjacent antennas in this compact MIMO system. Each antenna element has the dimensions of $0.30\lambda \times 0.38\lambda \times 0.012\lambda$. The whole MIMO antenna has the outer dimensions of $0.38\lambda \times 0.38\lambda \times 0.30\lambda$. The uniqueness of the proposed MIMO antenna is that the inner space of the hollow cylindrical structure can be used for hosting the associated signal processing unit of the whole system. Performance parameters of the proposed MIMO antenna are investigated using Computer Simulation Technology (CST). Envelope Correlation Coefficient (ECC) less than 0.033 and almost 10dB Diversity Gain (DG) are obtained at 2.4 GHz for this simple and compact antenna system. Ratio of Mean Effective Gain (MEG) of any two antennas is less than 0.02dB. Performance parameters of the proposed MIMO antenna system are compared with similar types of antennas found in recent literature.

Keywords: Antenna, MIMO Antenna, 2.4 GHz Antenna, Rectangular Patch Antenna, ECC, DG, MEG

I. INTRODUCTION

The use of multiple antennas at the transmitter and receiver in wireless communication systems, popularly known as MIMO technology, has rapidly gained its popularity in recent years due to its powerful performance-enhancing capabilities [1]. Multiple antennas at the transmitting and receiving ends improve the quality and reliability of a wireless link. In a wireless communication link especially in urban and indoor environments there is no clear line-of-sight between transmitter and receiver.

The signal from a transmitter propagates through different paths before being received by the receiver. Due to multipath propagation, the received signal strength may strongly vary, even for small changes of the propagation conditions. This variation in signal strength affects the link quality. This type of fading effects can result in an increased error or loss of the connection between devices. In MIMO antenna system the signal is transmitted and received

through multiple paths via multiple antennas. As a result, the probability that all replicas of signals will fade simultaneously is reduced considerably [2].

Two of the important aspects of MIMO antenna design are reduction of mutual coupling between antennas and miniaturization of the MIMO antenna system. A number of decoupling technologies are proposed in recent literature [3,4,5,6,7]. However, decoupling technology requires a distance of the order of operating wavelength between antennas to increase isolation, which limits the miniaturization of the antenna. Considerable research works, mostly on the planar configuration of the antennas, have been done in this field for overcoming the said difficulty.

In the present paper a novel design technique for MIMO antenna is proposed using four rectangular patch antennas in a three dimensional, nonplanar configuration. Operating frequency band of the proposed MIMO antenna is 2.4GHz, the most common ISM (Industrial, Scientific and Medical) frequency band for Wireless Local Area Network (WLAN). The performance parameters of the proposed antenna are investigated using CST software and are compared also with those of similar antennas found in recent literature.

II. ANTENNA DESIGN

Major aspects of MIMO antenna design are i) Good isolation between the antennas (ii) Compactness of the whole antenna system and iii) High gain of antenna at operating frequency range. Here four identical rectangular patch antennas are used for the MIMO system. FR4 material of thickness 1.5mm is used as the substrate of each antenna. Each patch antenna is fed with inset feeding technique using microstrip line.

These four antennas form a hollow cylinder of rectangular cross section as shown in Figure 1. Conducting ground plane material covers the bottom of the whole substrate of each antenna. Design parameters are shown in Table I and Table II.

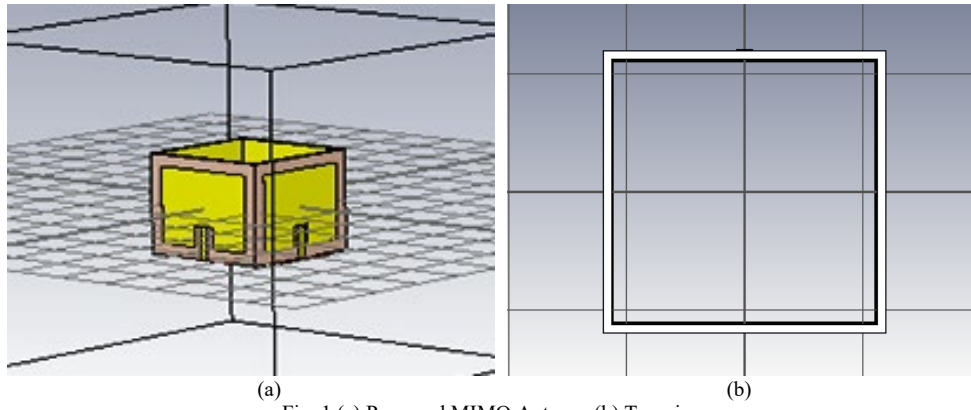

Fig. 1 (a) Proposed MIMO Antenna (b) Top view

TABLE I DESIGN PARAMETERS OF THE SINGLE RECTANGULAR PATCH ANTENNA

Length of patch (mm)	Width of patch (mm)	Length of substrate (mm)	Width of substrate (mm)	Height of substrate (mm)	Length of inset (mm)	Width of inset (mm)	Length of feed line (mm)	Width of feed line (mm)	Substrate material/ Dielectric constant
29	38.03	37.90	47.63	1.5	8.1016	6	12.55	3	FR4 /4.3

TABLE II DIMENSIONS OF THE 4 PORT MIMO ANTENNA

Shape	Length of wall (mm)	Height of wall (mm)	Wall thickness (mm)
Hollow cylinder of square cross-section. Each wall is a rectangular patch antenna.	47.63 (width of substrate of patch antenna)	37.90 (length of substrate of patch antenna)	1.5 (substrate thickness of patch antenna)

Uniqueness of the proposed design is that this four element MIMO would occupy $0.68\lambda \times 0.68\lambda$ area if it had planar configuration and adjacent antennas are oriented at 90° to each other, whereas, material of the proposed configuration occupies only $4 \times (0.38\lambda \times 0.012\lambda)$ area in a plane [Figure 2]. Thus only 4% area is occupied compared to planar configuration.

III. ANALYSIS OF THE PROPOSED MIMO ANTENNA

Performance of the proposed MIMO antenna is investigated considering the parameters given below.

1. Scattering or S Parameters (s_{ij})

Scattering parameter s_{ij} is a measure of the signal transmitted from j th port to i th port of a multiport MIMO antenna. Scattering parameter s_{ii} is a measure of the signal reflected back from the input port of i th antenna due to impedance mismatch. In the operating frequency range of an antenna s_{ii} must be less than -10dB for efficient operation of the antenna. In a MIMO antenna system, each port must be sufficiently isolated from all other ports. This means s_{ij} when $i \neq j$ must have very low values for isolated ports.

2. Envelope Correlation Coefficient (ECC)

ECC (ρ_e) is another important factor. It signifies the amount of overlapping of radiation patterns of different antenna

elements of the MIMO antenna system. ECC can be expressed in terms of s parameter as follows [8].

$$\rho_e(i,j,N) = \frac{|\sum_{n=1}^N s_{i,n}^* s_{n,j}|^2}{\prod_{k=i,j} (1 - \sum_{n=1}^N |s_{i,n}^* s_{n,k}|^2)} \quad (1)$$

N is the number of elements in the MIMO system.

3. Diversity Gain (DG)

Diversity gain is a measure of the reduction of transmission power when a diversity scheme like MIMO is introduced, without performance loss of the system. High value of diversity gain ensures good performance of the MIMO antenna. Maximum value is 10dB which implies no correlation between the antennas of the MIMO system.

$$DG = 10 \sqrt{[1 - \rho_e(i,j,N)]^2} \quad (2)$$

4. Mean Effective Gain (MEG)

MEG is the measure of power received by the diversity antenna relative to the power received by an isotropic antenna in the fading environment [9]. For i th antenna of the system

$$MEG_i = 0.5 [1 - \sum_{j=1}^N |S_{ij}|^2] \quad (3)$$

The ratio of MEG values of any two antennas should be less than 3dB for good performance of the MIMO system.

IV. RESULTS AND DISCUSSION

Performance characteristics of the proposed MIMO antenna system are investigated using CST Microwave Studio software. Figure 2 shows that S_{11} , S_{22} , S_{33} and S_{44} parameters of the MIMO antennas are below -10dB in the frequency range 2.37GHz to 2.42GHz. Thus 10dB impedance bandwidth for these antennas is 50MHz. At centre frequency ~2.4 GHz $s_{ii}(i=1,2,3,4)$ parameter value is less than -17.4 dB for all the four antennas. Isolation is an important parameter for the MIMO antennas, high isolation or low coupling between the antenna ports results in an

enhanced efficiency of the individual antenna element and reduces the power loss due to mutual coupling. Also the high isolation between antennas makes them independent so that high diversity gains can be achieved [2]. s_{ij} (i not equal to j) is a measure of this isolation. In the vicinity of 2.4GHz isolation between any two antennas is better than -15.6 dB in this antenna system as shown in s_{ij} (i not equal to j) plot of Figure 3. Isolation between farthest antennas is -18dB or more at 2.4GHz. These values are quite satisfactory considering the small size and closeness of the adjacent antennas.

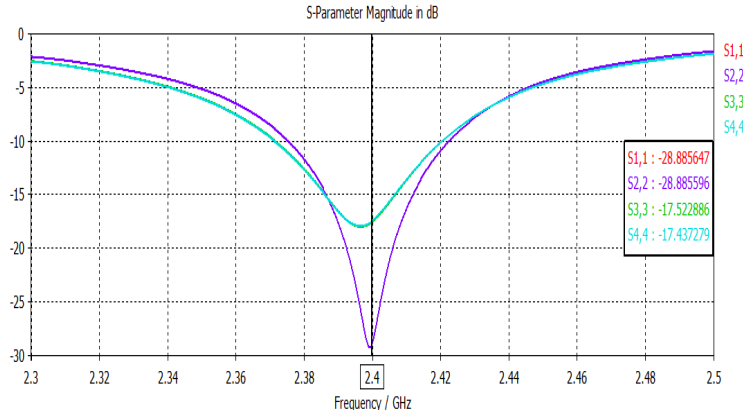

Fig. 2 Reflection coefficient versus frequency

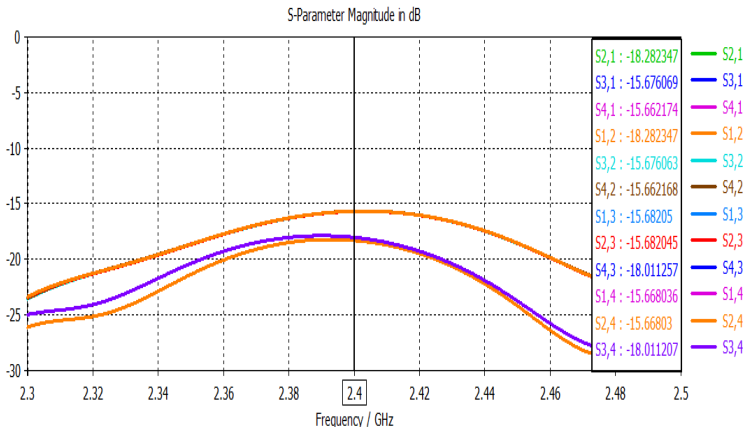

Fig. 3 Transmission co-efficients versus frequency

As already discussed ECC should be very small to ensure good pattern diversity for MIMO antennas. Figure 4 shows

correlation coefficients between different antennas are reasonably good (0.03 or less) at 2.4GHz.

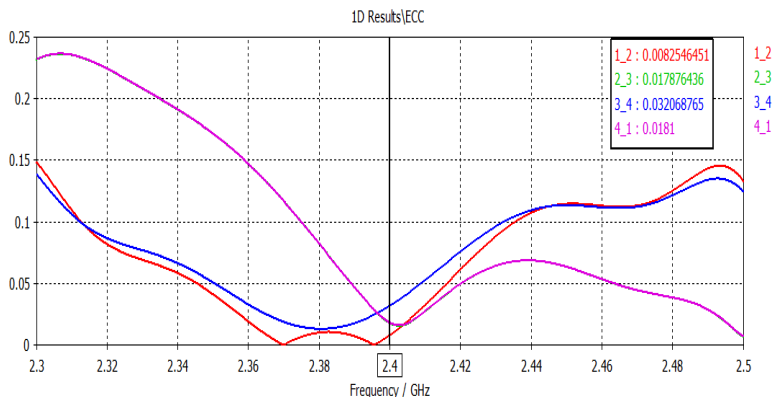

Fig. 4 ECC for MIMO antennas

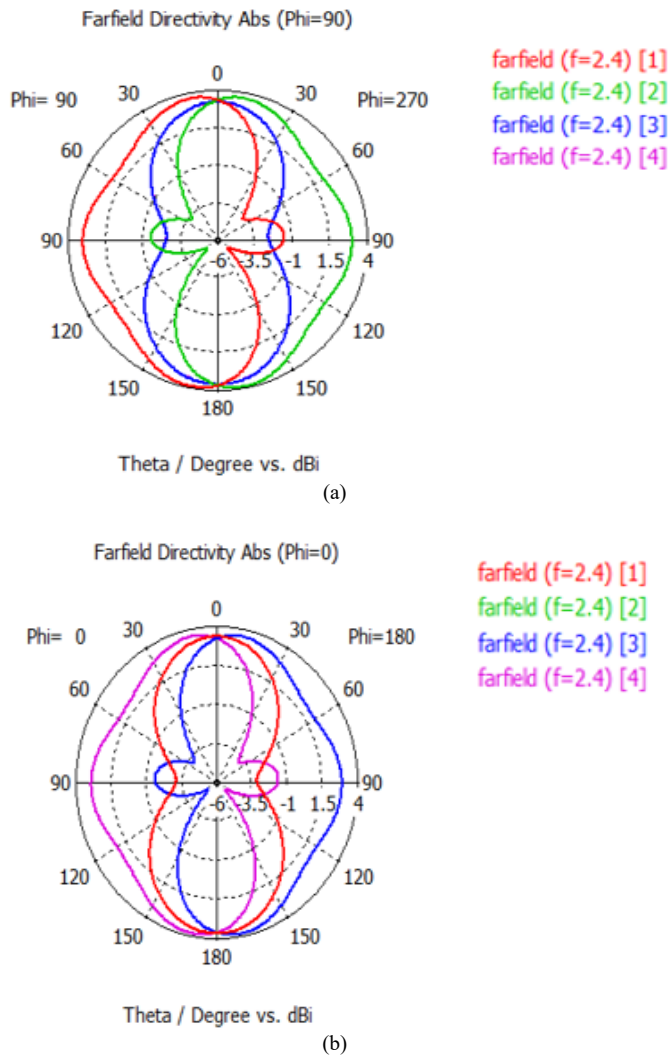

Fig. 5 Polar plot of far field directivity of MIMO antennas of Design 1. (a) $\phi=0^\circ$, (b) $\phi=90^\circ$

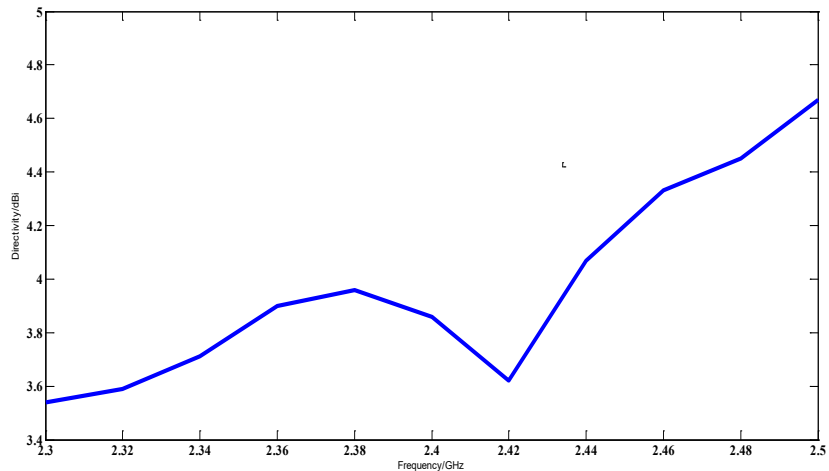

Fig. 6 Peak directivity versus frequency of single antenna

It is evident from Figure 5 (a and b) that radiation pattern of each antenna in the azimuth plane is oriented at 90° to each other and azimuth pattern diversity is obtained. Maximum directivity is around 3.9dBi at 2.4GHz for the identical

antennas of the system. Variation of directivity with frequency is shown in Figure 6. This moderate value of directivity is expected considering simple configuration of the antenna.

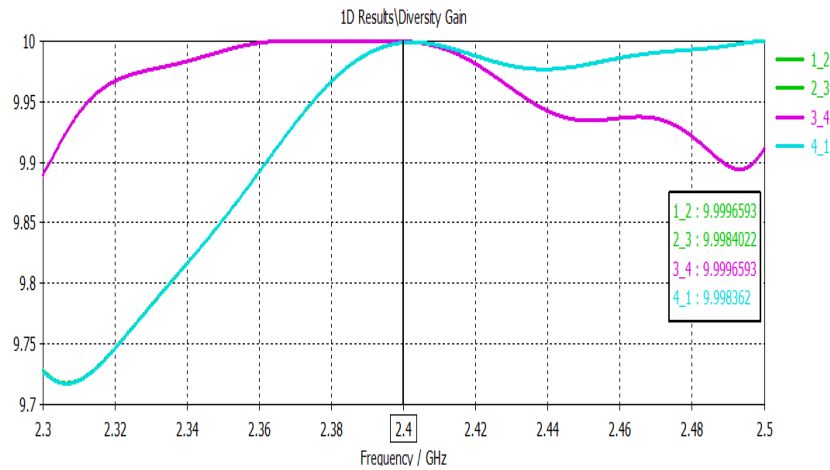

Fig. 7 Diversity gain of MIMO antennas

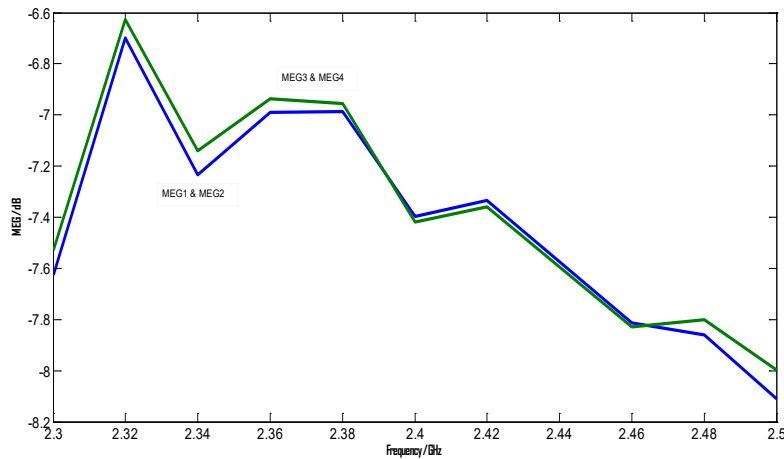

Fig. 8 Mean Effective Gain (MEG) versus frequency

Figure 7 shows the diversity gain is very good almost 10dB in the operating frequency range around 2.4 GHz. Figure 8 shows Mean Effective Gain (MEG) versus frequency. The MEG values are less than -6.6dB for all the antennas and

the ratio of MEGs of any two antennas of the system is 0.02dB or less in the operating bandwidth. These values are well within standard accepted limits for MIMO antennas.

TABLE III PERFORMANCE COMPARISON WITH RECENTLY PUBLISHED WORKS

Reference	Operating Frequency (GHz)	Bandwidth (GHz)	Area occupied (mm × mm)	Isolation (dB)	Gain (dBi)	ECC (dB)	DG (dB)	(MEG _i -MEG _j) (dB)
[1]	2.4	0.080	97.5x64	-13 -20(with DGS)	7	-	-	-
[9]	2.12-2.8	0.680	50x40	<-15	6.4	-	-	-
[10]	2.4	0.510	55x110	-10	-	-	-	-
[11]	2.5-14.5	12	30x50	-20	1 at 2.5GHz	<0.04	>7.4	-
Proposed	2.37-2.42	0.050	190.52x1.5	<-15.6	3.9	<0.033	10	<0.02

V. CONCLUSION

A four port MIMO antenna of simple as well as unique configuration is proposed and its performance characteristics are investigated. It occupies very small area (285.78mm²) on the hosting surface. This area is less than all the antennas referred in Table III. Antennas of [1] and [11] have better isolation values, however, these are two

port MIMO with more complex configurations and they occupy more area on a surface. Although antennas of [1] and [9] have more directivity values than the proposed antenna, other performance parameters of these antennas are not available for comparison. ECC and DG values of the proposed antenna are better than [11]. The performance parameters like ECC(<0.033), DG(~10dB) and MEG(<-6.6dB) of the proposed MIMO antenna are well within the

standard specified limits found in literature. The proposed MIMO antenna has the potential for being used in many types of WLAN applications at 2.4 GHz and can also be hosted on a vehicle surface with very small area requirement.

REFERENCES

- [1] R. Anuvind, A. Kothari and S. D. Joseph, "2x2 MIMO Antenna at 2.4 GHz for WLAN Applications," in *International Conference on Microwave, Optical and Communication Engineering, December 18-20, 2015, IIT Bhubaneswar, India ICMOCE-2015 International Conference on Microwave, Optical and Communication Engineering*, December 18-20, 2015, IIT Bhubaneswar, India.
- [2] Pravin W. Raut and S. L. Badjate, "Diversity Techniques for wireless communication," *International Journal of Advanced Research in Engineering and Technology, (IJARET)*, Vol. 4, No. 2, pp. 144-160, 2013.
- [3] M. Li, L. Jiang and K. L. Yeung, "A General and Systematic Method to Design Neutralization Lines for Isolation Enhancement in MIMO Antenna Arrays," *IEEE Trans. Veh. Technol.*, Vol. 69, pp. 6242-6253, 2020.
- [4] R. Yang, S. Xi, Q. Cai, Z. Chen, X. Wang and G. Liu, "A Compact Planar Dual-Band Multiple-Input and Multiple-Output Antenna with High Isolation for 5G and 4G Applications," *Micromachines*, Vol. 12, pp. 544, 2021.
- [5] D. Gao, Z. X. Cao, S. D. Fu, X. Quan and Chen, "A Novel Slot-Array Defected Ground Structure for Decoupling Microstrip Antenna Array," *IEEE Trans. Antennas Propag.*, Vol. 68, pp. 7027-7038, 2020.
- [6] J. Huang, G. Dong, Q. Cai, Z. Chen, L. Li, G. Liu, "Dual-Band MIMO Antenna for 5G/WLAN Mobile Terminals," *Micromachines*, Vol. 12, pp. 489, 2021.
- [7] Y. Dou, Z. Chen, J. Bai, Q. Cai, G. Liu, "Two-Port CPW-Fed Dual-Band MIMO Antenna for IEEE 802.11 a/b/g Applications," *International Journal of Antennas and Propagation*, 2021. DOI: <https://doi.org/10.1155/2021/5572887>.
- [8] Y. A. S. Dama, R. A. Abd-Alhameed, S. M. R. Jones, D. Zhou, N. J. McEwan, M. B. Child and P. S. Excell, "An Envelope Correlation Formula for (N,N) MIMO Antenna Arrays Using Input Scattering Parameters, and Including Power Losses," *International Journal of Antennas and Propagation*, Vol. 2011, pp. 1-7, 2011. DOI: <https://doi.org/10.1155/2011/421691>.
- [9] H. Peng, R. Zhi, Q. Yang, J. Cai, Y. Wan and G. Liu, "Design of a MIMO antenna with high gain and enhanced isolation for WLAN applications," *Electronics (Basel)*, Vol. 10, No. 14, pp. 1659, 2021.
- [10] N. B. A. Rahman, A. A. Al-Hadi, and R. Khan, "Study of user effects on two-port MIMO antennas at 2.4 GHz and 5.8 GHz for Wi-Fi and WLAN applications," *Bull. Electr. Eng. Inform.*, Vol. 8, No. 1, 2019.
- [11] A. Iqbal, O. A. Saraereh, A. W. Ahmad and S. Bashir, "Mutual coupling reduction using F-shaped stubs in UWB-MIMO antenna," *IEEE Access*, Vol. 6, pp. 2755-2759, 2018.