

Reduction of Source Current and Source Voltage Harmonics Using SHAPF

Preetha Sukumar¹, M. Ramachandran², K. Umamaheswari³ and A. Maryia Chithra Mary⁴

^{1&2}Assistant Professor, ³Associate Professor, Department of EEE,
V.S.B. Engineering College, Karur, Tamil Nadu, India

⁴Assistant Professor, Department of EEE, Sree Sowdambika College of Engineering, Aruppukottai, Tamil Nadu, India
E-Mail: preethu.karur@gmail.com

(Received 5 September 2018; Revised 30 September 2018; Accepted 18 October 2018; Available online 24 October 2018)

Abstract - This paper investigate the source current and voltage harmonics reduction under unbalanced supply condition. The current harmonics produced are reduced by the Shunt active filter. In order to reduce the voltage harmonics Shunt active filter is not capable. So SHAPF is designed to compensate the source current and voltage harmonics. SHAPF is also used for compensation of reactive power and improve power quality. It also eliminates series and parallel resonance. The control technique for the SHAPF is based on the Instantaneous Reactive Power Theory. Both the real and reactive power are changed in terms of voltage component. In order to compensate the source current and load voltage harmonics the reference voltage is calculated. Simulations are carried out on MATLAB-Simulink and results are presented.

Keywords: Active and passive Filter, SHAPF, Instantaneous Reactive Power Theory, Harmonics, MATLAB

I. INTRODUCTION

The Modern society is more dependent on electricity. Without electricity the life in the world is highly impossible. Power quality plays a very important role for the effective functioning of the power system components. The power quality became most important term in power sector. Mainly the end users are concerned about power quality issues. The main issues that occur in the power systems are transients, voltage sag/swell, noise which cause harmonics. This will affect the quality of power delivered to the end user [1]. The quality of power is affected by the deviation in the voltage, current or frequency. Harmonic is defined as the integral multiple of the fundamental frequency. It can be voltage harmonics and current harmonics in an electric power system which is caused due to non-linear electric loads. In power grid Harmonic frequencies are a major cause of power quality problems. The major effect of power quality problem is the production of harmonics. The presence of harmonics decreases the quality of power and may damage the end user equipment. Due to the harmonics, heating of underground cables, insulation failure occurs. It also leads to increase of losses and reduces the life-time of the equipment. In an AC power system, the current varies sinusoidally at a frequency of 50 or 60 hertz. When a linear load is connected to the system, it draws a sinusoidal current at the same frequency and the voltage. Current harmonics are occurred due to the non-linear loads. A non-linear load like

a rectifier is connected, it draws a current that is not essentially sinusoidal. The current waveform is more complex. It mainly depends on the type of load and interaction with other components. The most efficient solution to develop the power quality is by using the filters in order to reduce harmonics. There are many diverse filter topologies like- active filter, passive filter, hybrid filter.

The current harmonics is compensated with the help of passive filters. The Active filter is used to compensate the voltage harmonics. The Active filter adjusts the voltage at the load but cannot decrease the current harmonics in the system [2-3]. The hybrid filter is the arrangement of both the active and passive filter. Among various combinations the series Active Power Filter with a Shunt connected Passive Filter (SHAPF) is extensively used. To overcome the troubles of both passive filter and active filters, Series Hybrid Active Power Filters (SHAPF) has been used. It provides the cost valuable solution for the nonlinear load compensation. The performance of the SHAPF depends on the proper algorithm. The selection of configurations and control strategies are projected to lessen inverter capacity [4-6]. Many approaches have been designed. The instantaneous reactive power theory cause a great impact on harmonic isolation. The instantaneous active and reactive power has a normal component and oscillating component. This paper is prepared as follows. First, system configuration is presented in section I. The generalized definition of instantaneous active, reactive and apparent power quantity is presented in section II-A. The control strategy for the Series Active Filter is presented in section II-B. Simulation results are given in section III. The Simulation for the compensation for current & voltage harmonics, reactive power and unbalanced supply voltage is obtainable.

II. SYSTEM CONFIGURATION

Figure 1 shows the block diagram of Series Hybrid Active Power Filter. It consists of the shunt passive filter and series active filter with a series transformer. It acts as a harmonic isolator. The harmonic current is ended into the passive filter. The SHAPF eliminate the series and parallel resonance that occur into the system. The setup also reduces the need of the specific tuning of the passive filter. The harmonics that are

generated are eliminated by the passive filter. series active filter eliminate only higher order harmonics. So the rating of the active filter needed must be less compared to the conventional shunt active filters [7-9].

Series active filter compensate both the unbalanced voltage and harmonics simultaneously. The arrangement of this series active filter and shunt passive filter reduces the need for accurate tuning of the passive filter and it also eliminates the possibility of occurrence of both series and parallel resonance. The ripple filters are used to smother the switching ripples which are generated due to the high-frequency switching. The main reason for the coupling the transformers is not only to isolate the PWM inverters from the source but it also match the voltage and current ratings of the PWM inverters.

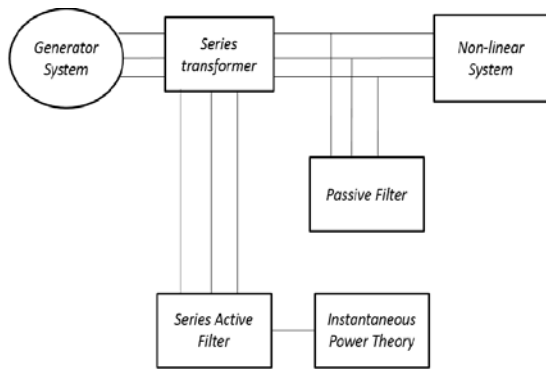

Fig. 1 Block Diagram of SHAPF

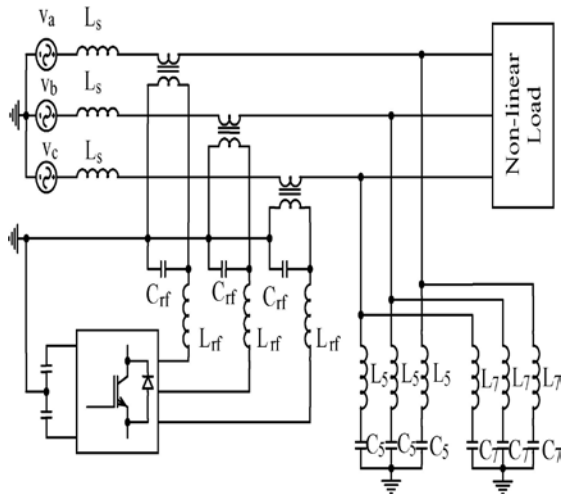

Fig. 2 SHAPF Topology Diagram

The turn ratio of the transformer must be high so that it reduce the amplitude of the inverter output and to reduce the voltage induced across the primary winding. The selection of the turns ratio of the transformer affect the performance of the ripple filter which is connected to the output. The series active filter in this setup is controlled as active impedance and it is controlled as a harmonic voltage source which provides

zero impedance at fundamental frequency and provides high impedance at all desired harmonic frequencies.

The SHAPF topology diagram is in the Figure 2. The series active filter is connected with the transformer which is connected in series to the system. The passive filter reduces the higher order harmonics and the fundamental harmonics are eliminated with the help of active filter connected in series. The series active filter is connected with the transformer through the ripple filter. The Capacitance value is assigned such that the harmonics are eliminated.

III. CONTROL SCHEME

A. Instantaneous Reactive Power Theory

"The Generalized Instantaneous Reactive Power Theory", also known as Instantaneous Power Theory or PQ Theory. The PQ Theory deals with the three phase circuits at the same time as a unity system. This Theory was given by Akagi, Kanazawa and Nabae in 1983. Control strategy presented in this section is capable of compensating the source current harmonics and it balance in load voltages. It deals with instantaneous power and classified into following two groups. The first one is developed based on abs phase to three orthogonal axes which is known as p-q theory that is based on a-b-c to α - β -0 transformation, and the next is directly on a-b-c phases. The main use of this theory is that it is valid for steady state or transitory operations. It also allow control the active filter in real time. The main advantage of using this technique is the calculation is simple. It require only algebraic calculation. The p-q theory consists of an algebraic Clarke transformation of the 3 Φ voltages and currents in the a-b-c coordinates to the α - β -0 coordinates, followed by the computation of the p-q theory instantaneous power components [10-11]. The 3 Φ instantaneous current can be distorted into α - β -0 axes. On applying the α - β -0 transformation, the zero sequence can be divided and eliminated.

B. Control Strategy

The Control strategy has a very significant role in the performance of the system. The instantaneous 3 ϕ currents and the 3 ϕ voltages are measured and transformed from a, b, c to $\alpha, \beta, 0$ coordinates by using the Clark transformation.

The a, b, c voltage are converted into $\alpha, \beta, 0$ coordinates by the Clarke transformation.

$$\begin{bmatrix} V_0 \\ V_\alpha \\ V_\beta \end{bmatrix} = \sqrt{\frac{2}{3}} \begin{bmatrix} 1/\sqrt{2} & 1/\sqrt{2} & 1/\sqrt{2} \\ 1 & -1/2 & -1/2 \\ 0 & \sqrt{3}/2 & -\sqrt{3}/2 \end{bmatrix} \begin{bmatrix} V_a \\ V_b \\ V_c \end{bmatrix} \quad (1)$$

The line current obtained from the Clarke transformation in terms of $\alpha, \beta, 0$ coordinates is

$$\begin{bmatrix} I_b \\ I_a \\ I_\beta \end{bmatrix} = \sqrt{\frac{2}{3}} \begin{bmatrix} 1/\sqrt{2} & 1/\sqrt{2} & 1/\sqrt{2} \\ 1 & -1/2 & -1/2 \\ 0 & \sqrt{3}/2 & -\sqrt{3}/2 \end{bmatrix} \begin{bmatrix} I_a \\ I_b \\ I_c \end{bmatrix} \quad (2)$$

The real power and reactive power are calculated from the voltage and current in terms of α, β coordinates is

$$\begin{bmatrix} p \\ q \end{bmatrix} = \begin{bmatrix} V_\alpha & V_\beta \\ -V_\beta & V_\alpha \end{bmatrix} \cdot \begin{bmatrix} I_\alpha \\ I_\beta \end{bmatrix} \quad (3)$$

Where

Instantaneous Real Power $p = V_\alpha I_\alpha + V_\beta I_\beta$

Instantaneous Imaginary Power $q = V_\alpha I_\beta - V_\beta I_\alpha$

The Instantaneous Real Power and the Instantaneous Reactive Power has both average power and oscillating power. The average power of the real and reactive power are expressed as \bar{p} and \bar{q} . The oscillating power obtained from the real and reactive power are expressed as \tilde{p} and \tilde{q} . The real power and reactive power can be obtained based on the average and oscillating power is

$$p = \bar{p} + \tilde{p} \quad (4)$$

$$q = \bar{q} + \tilde{q} \quad (5)$$

The α and β coordinates are to be considered and the zero sequence parameter is eliminated. The voltage corresponding to the α and β with the real power and the reactive power is obtained from (6).

$$\begin{bmatrix} V_\alpha^* \\ V_\beta^* \end{bmatrix} = \frac{1}{r_\alpha^* + r_\beta^*} \begin{bmatrix} I_\alpha & I_\beta \\ I_\beta & I_\alpha \end{bmatrix} \begin{bmatrix} \bar{p} \\ \bar{q} \end{bmatrix} \quad (6)$$

The reference voltage, compensate the harmonic voltage which is calculated in (7), which is obtained from the inverse Clarke transformation.

$$\begin{bmatrix} V_{ca}^* \\ V_{cb}^* \\ V_{cc}^* \end{bmatrix} = \sqrt{\frac{2}{3}} \begin{bmatrix} 1 & 0 \\ -1/2 & \sqrt{3}/2 \\ 1/2 & -\sqrt{3}/2 \end{bmatrix} \begin{bmatrix} V_\alpha^* \\ V_\beta^* \end{bmatrix} \quad (7)$$

The reference voltage and the source voltage are compared and the output signal is given to the comparator. The output from the comparator is used to control the controller [6]. The inverter is operated corresponding to the output obtained from the comparator. SHAPF inject the voltages that follow the reference voltage. It can compensate both the source voltage unbalances and produce current harmonics simultaneously. The particular features of this technique is computational complexity is less compared with existing techniques and it is simple in separating harmonic voltage component.

IV. SIMULATION RESULTS

The control algorithm for the SHAPF is designed in the MATLAB/Simulink. From the performance of the control strategy is improving the system behavior. The simulation is

carried out different conditions like Without Filter, With Passive Filter and With Active and Passive Filter The planned control strategy is simulated with a non-linear balanced load and the performance of the system is Tabulated. In the below table the system data is given as The load voltage and load current obtained when the system is in open loop without any filter is shown in the Figure 2 and Figure 3. Load voltage and Load Current obtained consist of more Harmonics which must be eliminated. The harmonics generated is eliminated with the help of filters. The FFT Analysis is carried out for the system without any filter. The THD values are calculated and it is 34.64%, which is higher shown in the Figure 4.

TABLE I SYSTEM PARAMETER

System Parameter	Value
Voltage	230 V
Source Inductance	10 H
Source Resistance	0.5
Turns Ration of Coupling Transformer	1:1

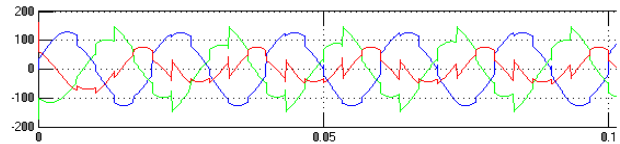

Fig. 2 Load voltage without any filter



Fig. 3 Load current without any filter

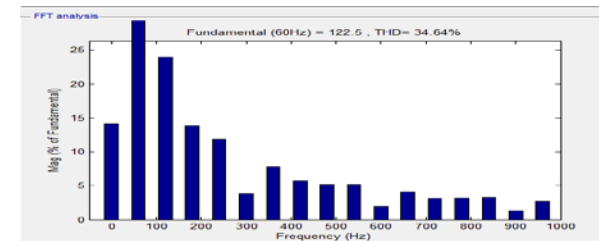

Fig. 4 THD Analysis without any filter

The load voltage and load current obtained when the system with passive filter is shown in the Figure 5 and Figure 6. The Load voltage and the load current obtained with passive filter consist of less harmonics.

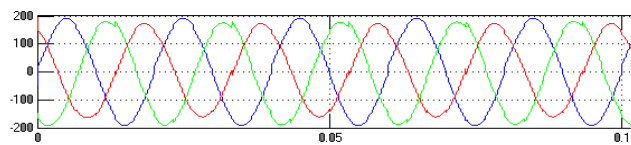

Fig. 5 Load voltages with passive filter

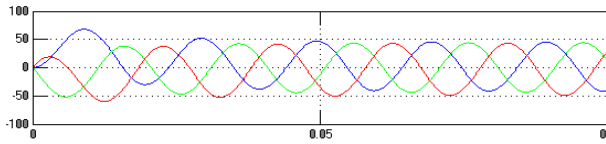

Fig. 6 Load current with passive filter

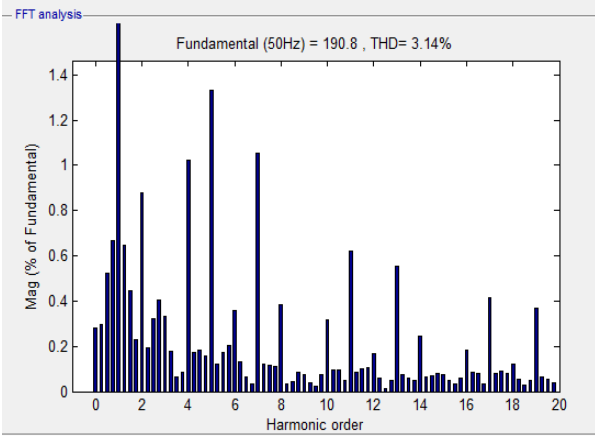

Fig. 7 THD Analysis with passive filter

The FFT Analysis is carried out. The THD values are calculated for the system with passive filter and shown in the Figure 7. The value is 3.14%, which is less compared with the system without filter. The load current and load voltage obtained when the system with both Active and Passive filter is shown in the Figure 8 and Figure 9. The Harmonics content in the load voltage and Load current obtained with the series connected active filter and shunt passive filter is comparatively low than the other.

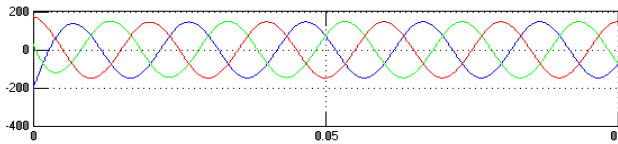

Fig.8 Load voltage with SHAPF

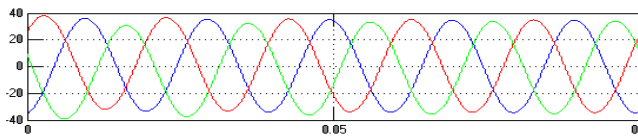

Fig. 9 Load current with SHAPF

TABLE II COMPARISON OF THE THD VALUES

System	THD Values in %
Without Filter	34.64
With Passive Filter	3.14
With SHAPF	0.18

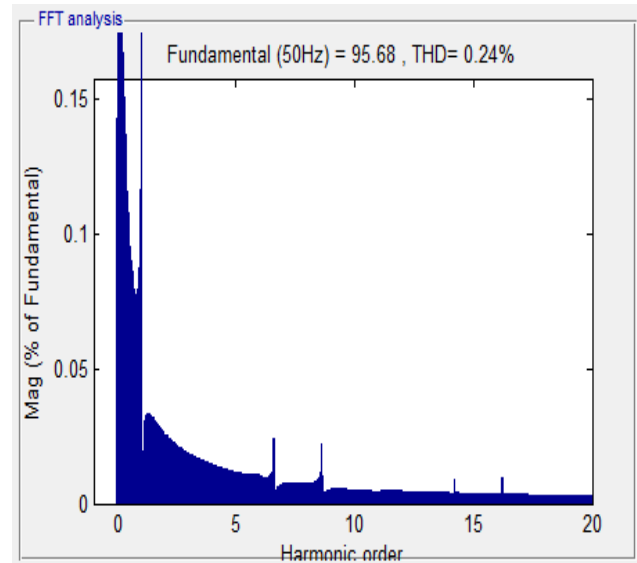

Fig. 10 THD Analysis with SHAPF

The FFT Analysis is carried out. The THD values are calculated for the system with SHAPF and shown in the Figure 10. The value is 0.24%, which is lesser compared with passive filter. The Table gives the THD value for the system (a) without filter, (b) With Passive Filter, (c) With Active and Passive Filter. The THD value that are obtained by the RL Load. From the table the THD value for the system with both Active and Passive Filter are very much less compared with the system with no Filter and system with Passive Filter. The voltage and current harmonics that are produced in the system will be eliminated with the Active and Passive Filter. The Active Filter is connected in series and Passive Filter is connected in parallel to obtain the necessary output.

V. CONCLUSION

The demand for electric power is rising at an exponential rate. But the quality of power delivered becomes the most important issue in the power sector. By reducing the harmonics and also by improving the power factor the performance of the power system can be improved. The power proves the electric power quality by the use of Active Power Filter is discussed. The loads connected to the system are non-linear which leads to the production of harmonics in the system. A Hybrid Active Power Filter which consists of series connected Active Power Filter and shunt connected Active Power Filter is used to reduce the harmonics. The simulation is also made under unbalanced load and found that the Filter the behavior of the system is improving by reducing the harmonics. Therefore, it is accomplished that the hybrid filter which consist of series Active Power Filter and a shunt passive filter is a practicable economic solution for improving the power quality and reducing the harmonics in electric power system.

REFERENCES

- [1] W. E. Reid, "Power quality issues-standards and guidelines", *IEEE Trans Ind. Appl.*, Vol. 32, No. 3, pp. 625-632, 1996.
- [2] J. C. Das, "Passive filters-potentialities and limitations," *IEEE Transaction Industry Applications*, Vol. 40, No. 1, Jan. 2004.
- [3] P. Salmerón and S. P. Litrán, "A Control Strategy for Hybrid Power Filter to Compensate Four-Wires Three-Phase Systems", *IEEE Transactions on Power Electronics*, July 2010, Volume 25, Issue 7, pp. 1923–1931.
- [4] Dr.K.Umamaheswari, M.Ramachandran, Mariya Chitra Mary A, Preetha S," Matrix Converter based series compensator for mitigating power quality disturbance". *Journal of Emerging Technologies and Innovative Research* Vol. 5, issue 9, September 2018, ISSN – 23459-5162
- [5] K.Umamaheswari and Dr.V.Venkatachalam, "Flyback with Half Wave Rectifier for Single Stage Power Factor Correction" *International Journal of Scientific and Engineering Research (IJSER)* Vol. 4, No. 4, April 2013 Edition (ISSN 2229-5518).
- [6] K.Umamaheswari and Dr.V.Venkatachalam, "Single Phase Converters for Power Factor Correction with Tight Output Voltage Regulation", *International Journal of Emerging Technology & Advanced Engineering*, Vol. 3, No. 2, February 2013.
- [7] K.Umamaheswari and Dr.V. Venkatachalam "Optimal Power Factor Correction Controller for Single Stage Power Converter", *International Journal of Applied Engineering Research (IJAER)* ISSN 0973-4562 Vol. 9, No. 23, pp. 21473-21499, 2014.
- [8] K. Umamaheswari and Dr.V.Venkatachalam "Optimal Power Factor Corrector of Single Stage Power Converter using BC tuned PID Controller", *Journal of Intelligent and Fuzzy System (JIFS)*, Vol. 30, No. 6, pp. 3155-3166, 2016.
- [9] Dr.K.Umamaheswari "Perturbation On-Time (POT) Technique to improve Power Factor Correction and Low THD" *Journal International Journal of Advance Research in Science and Engineering*, Vol. 7, No. 1, January 2018
- [10] J. Tian, Q. Chen and B. Xie, "Series Hybrid Active Power Filter based on Controllable Harmonic Impedance", *IET Journal of Power Electronics*, 2012, Vol. 5, No. 1, pp. 142-148.
- [11] H. Akagi, Y. Kanazawad, and A. Nabae, Instantaneous power theory and application to power conditioning" IEEE Press, Wiley-inter-science, A Jon Wiley & sons, INC., Publication.
- [12] M. F. Shousha, S. A. Zaid and O. A. Mahgoub. "Better Performance for Shunt Active Power Filters" *Clean electrical Power (ICCEP)*, *IEEE*, June 2011
- [13] H. Fujita, H. Akagi, "A practical approach to harmonic compensation in power systems series connection of passive and active filters," *IEEE Transactions on Industry Applications*, Vol. 27, Nov.-Dec. 1991.
- [14] M. A. Mulla, Chudamani, R. Chowdhury, 'A novel control scheme for series hybrid active power filter for mitigating source voltage unbalance and current harmonics'. Presented at the Seventh Int. Conf. on Industrial and Information Systems (ICIIS-2012) held at Indian Institute of Technology Madras, Chennai, India, 06–09 August 2012.