

Automatic Transformer Cooling System Using PLC

S. Bharathidasan¹, N. Balamurugan², B. Susithra³, M. Nishad⁴ and B. Sankar⁵

¹Associate Professor, Department of Electronics and Communication Engineering,

^{2,3,4&5}UG Student, Department of Electrical and Electronics Engineering,

Sree Sakthi Engineering College, Coimbatore, Tamil Nadu, India

E-Mail: ktvrbharathi@gmail.com, bravobalak@gmail.com, susithrabalan1997@gmail.com

(Received 12 December 2018; Revised 10 January 2019; Accepted 29 January 2019; Available online 6 February 2019)

Abstract - In the previous 20 years transformer warming is a noteworthy issue in creating station, substation, circulation locale and different territories. The primary driver of overheating are Insulation overheating, Corona overheating, Liquid overheating, Arcing is overheating, screen testing overheating. Because of this it causes numerous issues, for example, Coil harm, bursting of transformer, Block of wind, and so forth. To lessen the warmth which is created from the transformer, to trip the transformer when it is in over warmth condition and the stop the absolute circuit for upkeep period a we have built up this task dependent on Programmable Logic Controller.

Keywords: Programmable Logic Controller, Corona, Coil Damage, Arcing

I. INTRODUCTION

The transformer is a system which converts one voltage level into another voltage level without changing its frequency during this process, a loss occurs in the core and windings of the transformer. These losses are known as heat losses. Due to the heat losses in the transformer the transformer output will be less than the input power. The transformer heat gets increased with the increase of capacity of the transformer.

The types of cooling system applied in transformer are air cooling, oil cooling, water cooling, oil and water cooling. In past years these cooling system has been done manually. Due to manual operating it gets disadvantages such as over heat cannot be recognized, problem recognizing is difficult etc.

To diminish the Down-time of existing framework without irritating security and electrical interlocking courses of action, and to up-dates framework control Programmable Logic Controller (PLC) will be the best decision at our hand. The Internal and outside cooling methods might be furnished in a powerful way with parcel more included offices by bringing PLC into activity. Nearly, 90% of Industries are quickly exchanging over to this most recent innovation. Over 90% of physical wiring will be kept away from. It is a demonstrated innovation for any dimension of process confusions. Our venture bargains how PLC might be acquainted with screen a G.T to begin cooling fans (Forced Air Cooling) what's more, to begin oil siphons (Forced Oil Cooling) with other incorporated claim assurances of transformer and related switch-yard control exchange components. To look at how predominant the

PLC is we take conventional transfers rationale based control for a similar action alongside standard of working and how the circuit is framed utilizing Electro Mechanical Relays and clocks, to give time delays in process. The present PLC renders us predominant control and correspondence offices as well. Generator Transformer right away called G.T is a Power.

A. Generator Transformer

Transformer has a capacity of 250 MVA. It plays an essential job in any of the Power Stations to venture up the producing voltage to lattice offered dimension of either 230 KV or 400 KV. The term Power Transformer is utilized for limit more than one MVA.

$$P = VI \cos \Phi \text{ -----(1)}$$

Where, P= Power in watts, V = Voltage in Volts, I = Current in Amps, The above equation can be written as, $V=P/I$

Since the Generator Transformer is Power Transformer whose limit is 250MVA with yield of 230KV, observing the temperature of Oil and Winding will be a urgent one.

The cooling arrangement of the G.T is for the most part subdivided into three classifications. They are as per the following,

1. ONAN (Oil Natural Air Natural)
2. ONAF (Oil Natural Air Forced)
3. OFAF (Oil Forced Air Forced)

II. LITERATURE SURVEY

The maturing of intensity transformer is exposed to the winding protection and the oil inside the transformer [1]. One of the issue is that lead to breakdown of the protection is brought about by the change of warm warming whether from inside or outside the transformer. The other case that is caused the breakdown of the protection of intensity transformer is the transformer stacking dispatch. The transformer cooling framework has incorporated the electrical fan to fill in as a coolant utility for the radiator. It has been the successful strategy to keep the warm state of intensity transformer has a decent condition toward the task time. The existing cooling framework use thermocouple as a sensor for the warm pointer. This framework is frequently being delicate and can cause the quickening of transformer maturing. The framework has been upgraded by making the

cooling framework utilizing load marker as a excess framework for power transformer cooling framework. This impromptu creation has been executed to keep the great state of warm condition in power transformer.

To meet out the future burden request, electrical industry should be cost proficient [2]. Existing transformer speak to as an affirm subsequently checking will be prime factor for viable utilization of these transformer. Web based checking framework infers the administrator to upgrade the heap which has chance over the usefulness of transformer. In control framework transformer assumes an essential job in the traditional air conditioning framework. Accordingly a few transformers are basic due to more power taking care of limit. Power transformer is a one such transformer whose limit is more than 1MVA. such a transformer must be given more significance. So as to enhance the execution, cooling framework and assurance plot must be utilized. This frame works way great exhibitions along with cost proficiency.

It is proposed for computing the transformer temperature mode, when working with changing burden plan for irregular time interim (day, month & year) [3]. Transformer load specialized and money related assessment has been completed to characterize parameters that don't require impediment of new buyer associations. For the capacity of programmed power bookkeeping framework, checking is suggested of the cooling surrounding temperature for ensuing subjective appraisal of the warm weakening of the curl protection and the rest of the life expectancy of transformers, as per the proposed system.

Discrete cooling framework transformer is inclined to be picked amid the development procedure of underground transformer substation in significant urban areas, while there are few explores on the radiation of discrete cooling framework transformer [4]. In this paper, ICEM CFD programming is connected to build up the disentangled model of discrete transformer dependent on the hypothetical examination of warm conduct of typical one-piece transformer. To rearrange the model, winding and iron center tough to be considered as principle warm source in the displaying procedure. In this model, the transformer is considered overall, the Bossiness show in Fluent is utilized to mimic the warm field what's more, oil stream field within transformer, and the variety of physical qualities of transformer with temperature is taken into record. From that point forward, the product CFD-Post is connected to streamline the count result and get the reprogram of temperature and speed stream graph. From the examination of warm recorded, the temperature and explicit position of hot-point are resolved; this gives the premise to hot-point estimation of transformer. Additionally, the variety of warm field of discrete cooling framework transformer with distinctive outside temperature is get by changing the outer condition, and its warm field is analyzed with the one of ordinary one-piece transformer, so the prevalence of discrete cooling framework in pragmatic application framework is demonstrated.

Transformer assumes an indispensable job in transmission and appropriation framework [5]. There are numerous issues related with control misfortune in transformer yet this paper for the most part centers on effective cooling framework intended for beating warming and protection misfortunes. With the usage of keen matrix and savvy urban communities, the conventional control method of transformer's cooling framework can't fulfill the new need. In a perfect world PLC is utilized for web based observing and information recording. In our paper, we have proposed a canny cooling framework dependent on Programmable Rationale Controller (PLC) which annihilates the issue of manual transformer cooling control framework via consequently exchanging between the cooling banks. The cooling framework in our paper includes three cooling banks, each having a fan and a siphon. At once, two out of three cooling banks will work. In instance of disappointment of any of the working banks, the third bank will consequently switch on instead of the defective bank. Thus third bank will keep on working until broken bank is fixed. This exchanging between cooling banks is PLC controlled and in this manner destroys the mistakes brought about by human intercession. Alongside this, consistent observing and information recording is all the while done. We have additionally centered upon legitimate use of reserve bank by methods for occasional exchanging.

The sequence has shown the appropriateness of the warm system and CFD models to a characteristic cooling, strong protection dry-type transformer [6]. Approval demonstrates that the LV winding has a less complex development and accordingly has showed signs of improvement demonstrating precision. Future investigations will incorporate rectifying the over-estimation of the HV cooling. The subtleties of the HV turns furthermore, transform protection should be considered, coming about in a lower successful warm conductivity, all together for the expected precision for the HV twisting to be made strides.

The examination has demonstrated the propriety of the warm framework and CFD models to a trademark cooling, solid security dry-type transformer [7]. Endorsement shows that the LV winding has a less intricate advancement and in like manner has hinted at enhancement showing exactness. Future examinations will fuse redressing the over-estimation of the HV cooling. The nuances of the HV turns moreover, change insurance ought to be considered, coming to fruition in a lower effective warm conductivity, all together for the expected exactness for the HV curving to be made progress.

In this commitment, a 2D and 3D reproduction demonstrate was introduced to decide the oil speed of an OD cooled winding pursued by an examination of the problem area temperature and its position [8]. The introduced winding model, which has been approved by exploratory outcomes, gives valuable understanding into the level cooling channels opposite to the fundamental oil stream bearing. The tentatively decided oil stream speeds and their optical examination demonstrated a decent concurrence with the

relating numerical information and, in this way, affirmed the reasonableness of 3D numerical models to figure the winding warm conduct. The examination showed solid non-uniform oil stream dissemination on the level channels affecting the situation of the problem area. The investigation likewise demonstrated that the oil stream speed in the upper channels is more prominent than the lower ones. Correspondingly, the cooling in the lower channels is less and, hence, the problem area happens in the base territory of each pass. The introduced model can be used by transformer creators to streamline the cooling of control transformer windings.

III. PROPOSED METHOD

A. Block Diagram

The Figure 1 show the cooling system is done by the help of PLC the major component in this diagram is the PLC, IR Sensor, thermistor, centrifugal pump, SMPS, buzzer and LED. The thermistor senses the temperature in the transformed and it is fed to PLC.

The output of the PLC is connected with fan and centrifugal pump. If the heat increases the output gets on and off in the temperature increased or decreased condition. The fan and centrifugal pump are sensed by the IR sensor weather it is running or not and the output is given to the PLC. In case the fan and centrifugal pump didn't work the supply to that fan and pump gets cut off and gives alarm to the control station.

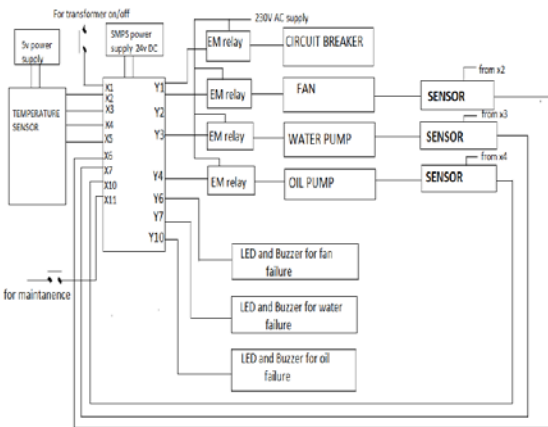

Fig. 1 Cooling system using PLC

B. SMPS

An electronic circuit that converts power using switching devices that are turned on and off at high frequencies, and storage components such as inductors or capacitors to supply power when the switching device is in its non-conduction state. The switched mode power supply too converts the available unregulated ac or dc input voltage to a regulated dc output voltage. Switching power supplies have high efficiency and are widely used in a variety of electronic equipment, including computers and other sensitive equipment requiring stable and efficient power supply.



Fig. 2 SMPS

C. PLC

A programmable logic controller (PLC) or programmable controller. It is an industrial digital computer. Robotics devices or any activity that requires high reliability control and ease of programming and process fault diagnosis. Programmable Logic Controller (PLC) is a digital computer used for the automation of various electro-mechanical processes in industries. These controllers are specially designed to survive in harsh situations and shielded from heat, cold, dust, and moisture etc. The program is written on a computer and is downloaded to the PLC via cable.



Fig. 3 PLC

D. Infrared Sensor

A device which can detect motion by receiving infrared radiation. Infrared radiation is an electromagnetic wave with wavelength of 700nm to 1 mm. It is emitted by objects with temperature above 0 Kelvin. Furthermore intensity and wavelength of infrared radiation depends on the temperature of the object. The infrared sensors are the sensors that detect/measure infrared radiation or change in the radiation from outer source or inbuilt source. Also sensors that use the property of infrared radiations to detect the changes in surrounding are termed as infrared sensors.

IV. LADDER LOGIC DIAGRAM

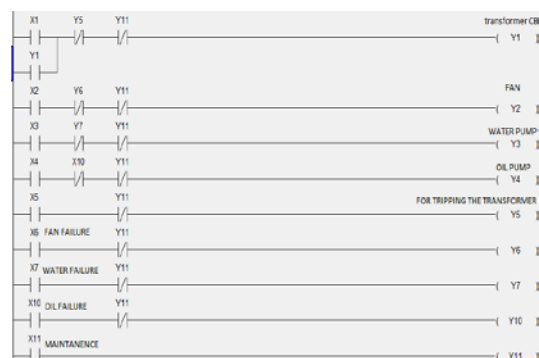

Fig.4 Ladder logic diagram

In this (fig. 4) we have developed ladder logic diagram by using delta PLC simulation in this project. It consists of nine cases. We are monitoring and controlling the transformer and cooling system by PLC. The software we are using WPL 2.47 (latest version).

V. RESULTS AND DISCUSSION

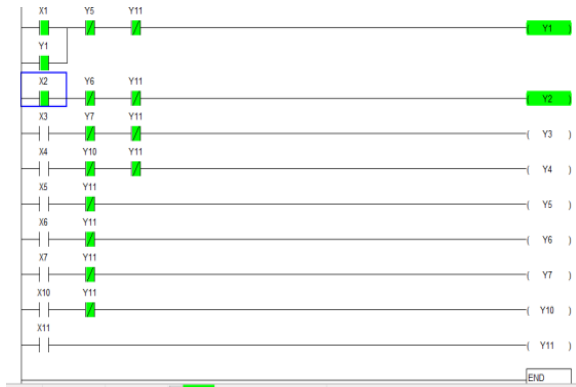

Fig. 5 Simulation Output at 30 degree

If the temperature increases to 30 degree the x2 gets on and the (y2) fan gets ON. Because the transformer is not much. So the fan cools the transformer for the limited temperature till 60 degree.

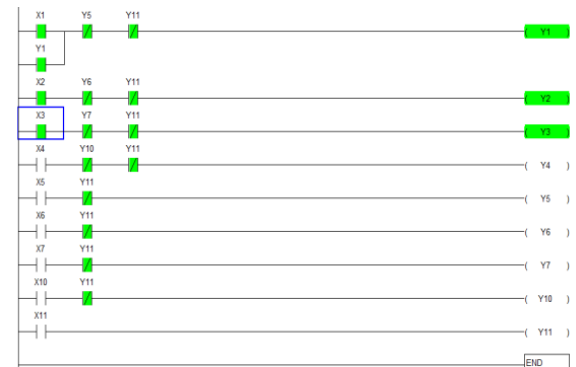

Fig. 6 Simulation Output at 60 degree

If the temperature increases to 60 degree the x3 gets on and the (y3) water cooling system gets ON. Because the temperature is slightly high it may cause damage. So the water cools the transformer.

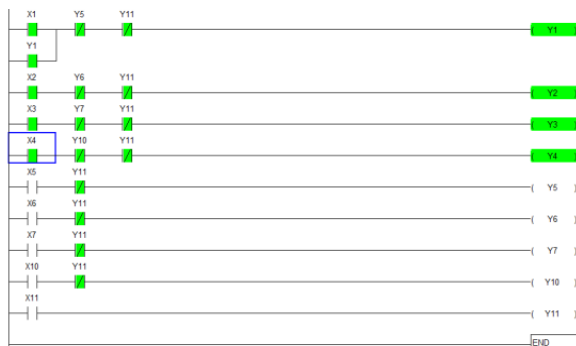

Fig. 7 Simulation Output at 90 degree

If the temperature increases to 90 degree the x4 gets on and the (y4) oil cooling system gets on. Because the temperature of the transformer is quite high so the oil cooling system is also gets ON condition.

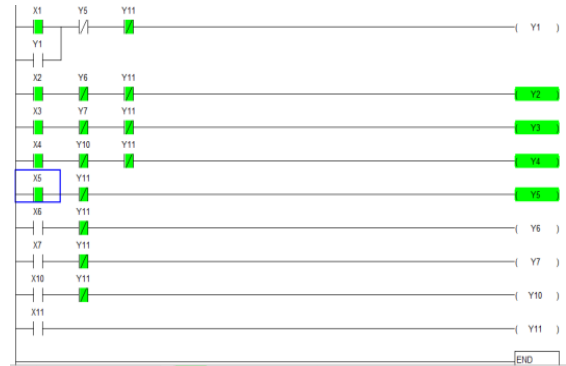

Fig. 8 Simulation Output at more than 90 degree

If the temperature increases more than 90 degree the (y5) gets on and trips the input of the transformer. Because it causes damage to the transformer winding and there are chances for burning, bursting of transformer so we are cutting the input supply of the transformer.

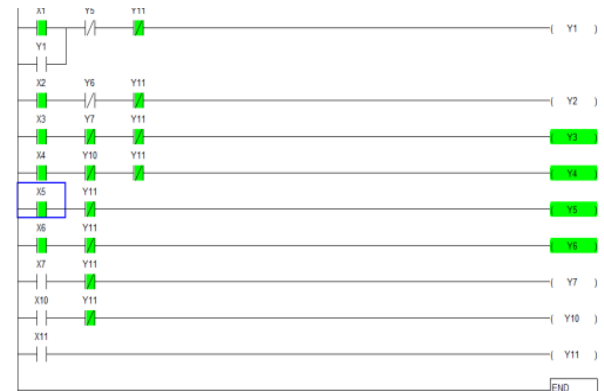

Fig. 9 Simulation Output at more than 90 degree fan off

If the fan does not works an x6 gets on and trips the supply of the fan and gives alarm to the control station. When the fan is not in a working condition there are chances for more damages in the motor so we are tripping the input of the cooling system.

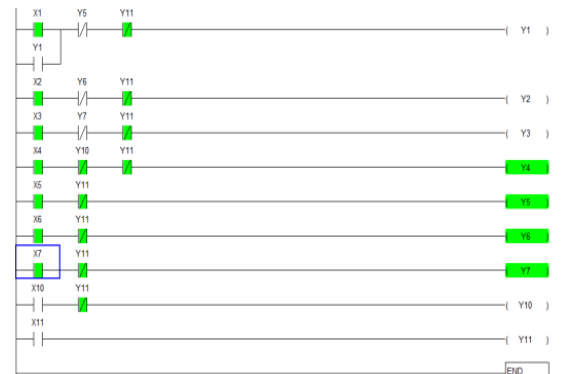

Fig. 10 Simulation Output at more than 90 degree water cooling off

If the water cooling system didn't work the x7 gets on and trips the supply of the water cooling system and gives alarm. When the centrifugal pump is not in a working condition there are chances for more damages in the motor so we are tripping the input of the cooling system.

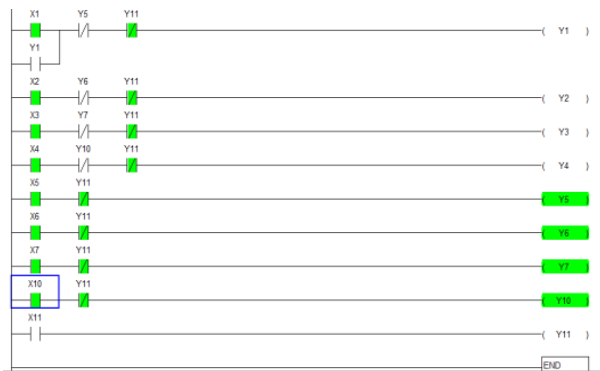

Fig. 11 Simulation Output at more than 90 degree oil cooling off

If the oil cooling system didn't work the x10 gets on and trips the supply of oil cooling system and gives alarm. When the centrifugal pump is not in a working condition there are chances for more damages in the motor so we are tripping the input of the cooling system.

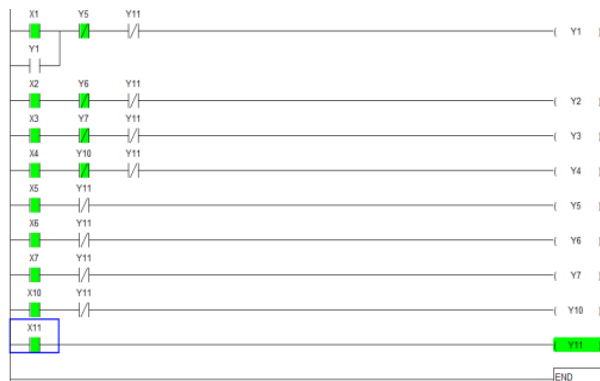

Fig. 12 Manual Maintenance

For maintenance purpose the x11 is used and it is used manually. If the x11 gets on the total output gets off condition. This switch is given when there is any service in the transformer, excess installation of transformer etc.

VI. CONCLUSION

In this we have been developed an easy monitoring and controlling system of transformer. Due to this project we can control a transformer inside the control room the equipment will be safe and there will be no damage in transformer and other cooling system. Inconveniences shooting knowledge winds up less demanding presently contrasted with existing innovation. PLC is easy to

understand Hardware whose task for the most part relies upon our own-composed Programming in its memory. Over 90% of physical wiring can be stayed away from. It is a demonstrated innovation for any dimension of process complexities.

VII. FUTURE WORK

We can give indication to the main substation by the help of cloud or GSM to know what's happening in branches of the main substation. In future we can develop the monitoring and control system with the help of cloud server in the individual substation and also in the main substation. Due to this the monitoring and controlling is been done in an easy way.

REFERENCES

- [1] M. Helmi Prakoso and Heri Gunawan, "Redundant Control of Power Transformer Cooling System Using Actual Load Indicator", *Proceedings of IEEE 10th International Conference on Information Technology and Electrical Engineering (ICITEE)*, 2018.
- [2] S. Sankar, R. Raghul, C. Selvakumar, and A. Sasidha, S. Jaisiva "250MVA generator transformer cooling system control using plc", *proceedings of IEEE International Journal of Pure and Applied Mathematics*, Vol.119, No. 14, 631-636,2018.
- [3] Vladimir N. Kostin, Tatyana E. Minakova, and Alexandra V. Kopteva, "Urban Substations Transformers Allowed Loading", *proceedings of IEEE*, published on 2018.
- [4] Ruo Chen Guo, Jie Lou, Zhen Wang, Hua Huang, Bengang Wei, and Yuying Zhang, "Simulation and Analysis of Temperature Field of the Discrete Cooling System Transformer Based on FLUENT", *proceedings of IEEE 1st International Conference on Electrical Materials and Power Equipment*, on 2017.
- [5] Shreenivas Pai, Karna Desai, Archana Doshi, Neha Bansal, Devendra Mohesarkar, and Mihir Pathare, "Intelligent PLC based transformer cooling system", *proceedings of IEEE International Conference on Nascent Technologies in the Engineering Field (ICNTE)*, published on 2017.
- [6] W. Wu and J. A. Kern "Temperature raise prediction of a natural cooling dry type transformer", *proceedings of IEEE*, published on 2016.
- [7] I. Hurezeanu, C. I. Nicola, D. Sacerdoianu, M. Nicola, A. M. Aciu and M. C. Nitu, "Temperature control and monitoring system for power transformer winding using fiber optic sensor", *proceeding of IEEE, International Symposium on Fundamentals of Electrical Engineering*, University politehnica of Buchrest, Romania, June30-July2,2016.
- [8] S. Tenbohlen, Senior Member, IEEE, N. Schmidt, C. Breuer, S. Khandan, and R. Lebreton "Investigation of thermal behavior of oil directed cooled transformer winding", *proceedings of IEEE*, on 2016.
- [9] N. M. Neethu, Anil Das, Sarath S. Nithin Premsy and Anagha VJ. "Smart transformer using PLC and SCADA", *proceedings of IEEE, International Journal of Multidisciplinary Research and Development* Vol.3, No.6, June 2016.
- [10] Guojin Chen, Ming Xu, Tingting Liu, Jing Ni, Dong Xie and Yanping Zhang, Hangzhou Kelin Hangzhou, Zhejiang "Intelligent control system of transformer based on dcs and dual plc", *proceedings IEEE Fifth Conference on Measuring Technology and Mechatronics Automation* on 2013.