

Automatic Corporation Water Supply Control Using Arduino

S. Bharathidasan¹, Y. Farisha², R. Harisoothanakumar³, U. Rajeshwari⁴ and J. Suryaprabha⁵

¹Associate Professor, Department of Electronics and Communication Engineering,

^{2,3,4&5}UG Student, Department of Electrical and Electronics Engineering,

Sree Sakthi Engineering College, Coimbatore, Tamil Nadu, India

E-Mail: ktvrbarathi@gmail.com, farishayacoob7@gmail.com, hariramanathan665@gmail.com

(Received 13 January 2019; Accepted 15 February 2019; Available online 22 February 2019)

Abstract - The main aim of our project is to control the corporation water supplying for several areas from one control board. Here we have used Arduino board for controlling the System. For the communication purpose Radio Frequency (RF) transmitter and receivers are used. This will made the system more efficient for signal and information passing. Our project proposes an economic, efficient, eco-friendly system for controlling the corporation water supply. The advantages by our project are time management, proper drinking water supply with defined time, can reduce wastage of water.

Keywords: Arduino, RF module

I. INTRODUCTION

Water is a basic need for all living being. Thus proper water supply is necessary for all. Our project portrays about a proper water distribution with timing. Thus by providing regular and defined water supply there will be a reduced problem for water in the towns and cities. In our project we have proposed a system for controlling the corporation water supply from the control unit. This also reduces the man power. The main aim of our project is to provide corporation water supply with proper timing from one place (control unit). We are using Arduino as controller and RF module for communication. When our project is implemented everywhere wastage of water also reduced, because of a desired timings and calculated water levels. We can implement this project in all towns and modern cities.

II. LITERATURE REVIEW

The Internet of Things (IoT) gather valuable information with the assistance of different existing innovations and after that self-sufficiently stream the information between different gadgets. The Raspberry PI controls the Solenoid esteem. Every one of the information is gathered with a raspberry pi and it process constantly and drive information on to the cloud. The cloud utilized here is things peak it's a free cloud accessible to a few breaking points. Here the qualities will be transferred once in 15sec [1].

In this project, it is proposed to build up an inserted based remote water observing and robbery counteractive action framework by account the stream rates at the consumer end. Depending upon the level of the water the speed of the motor will be varied Computation of bill on premise of water utilized. Circulation of water as indicated by the bill installment. Status reports on portable through Global

System for Mobile communication (GSM) Module. PYTHON database Graphical user interface (GUI) for charging the board. Customer data and revive office. On the off chance that water level in the primary tank is above 90% then naturally the DC siphon will be killed. At the point when the water level in the fundamental tank is at or beneath 20% then DC siphon will naturally turn ON [2].

This paper exhibits a design for Smart Water Distribution System (SWDS) that corporate the IoT and Distributed computing innovations with Information and Communication Technology (ICT). The framework gathers the information from sensors by a predefined interface, dissect the information and show the outcomes on a sequential port terminal. The information is put away in the Cloud and it is transferred to the online life. Wireless Sensor Networks (WSN) layer is a gathering of associated sensors, RFID peruses, cameras, M2M terminals and any gadget may gather information from nature. RFID is the most utilized WSN hub. IoT is the execution condition to all keen sensor [3].

UGM Implementing activities comprise of four stages that include preparation phase, data collection phase, processing stage and stage of presentation Digital Terrain model (DTM) Modeling is vital in light of the fact that the aftereffect of the displaying for example DTM is utilized as the premise of elevation for all objects that exist, both above and underneath the dirt surface. Through the expelling technique, the building 2D information is pulled up from the DTM with the assessed rise esteem acquired from the increase of the quantity of floors with the assessed stature of the building per floor being 7.5 meters. The arrangement of room or 3D objects is done through expelling existing information as per the stature and thickness of each faucet water. 3D modeling of DWSS network distribution can be built and presented as an offline application in Arc Scene [4].

Because of the information and process conduct here used principally Kalman recursions for portraying and assessing the specialized condition of water organize the evaluated information are acquired from in-field perceptions and operational records. Two standards of methodologies are used. The first is a Markov chain (MC) display utilized for deciding the state likelihood and a general specialized conduct of a water dispersion framework. The second

model, which we are going to utilize, is a state-space demonstrates – the Kalman recursion. Direct frameworks utilize such created methods for control from starting. The methodology dependent on unique straight models is for this situation exceptionally successful since just truncated information and constrained records about the watched framework disappointments are accessible [5].

The administration framework comprises of two parts segment. The Water Management Station and the Branch Station. The water supply scale is ceaselessly extended with the expanding necessity of the water quality and quantity. According to the underlying structure report, four same sort diffusive siphons ought to be settled in sponsor siphon station and each siphon continued lifting water for 22 hours. While the water request is high, the everyday running time will be expanded. At the point when the water level surpass the notice level or on the other hand underneath the most reduced water level, alert flag would be transmitted to the control focus, at that point a flag of stop (begin) siphon send back, ball valves of siphon consequently shut or open through the remote control[6].

In this undertaking they are chipping away at the conveyed arrange under the region of single water tank. Pressure transmitter is utilized for estimating pressure of approaching stream. And this data is seen on SCADA framework. Level sensor is utilized for estimating the dimension of water in water tank. Here, we are utilizing ultrasonic dimension sensor. To realize how much dimension it will get filled, the dimension sensor is utilized is a principle controller which takes I/p from information lumberjack and passes this data to the particular designer, with the assistance of GPRS system. The PLC is primary controller utilized for putting away these all data and controlling reason [7].

The proposed system uses DSP processor GSM modem image sensor and solenoid valve. DSP processor is used to interface GSM modem image sensor and solenoid valve. Image sensor is placed on the mechanical meter at the time of billing the central server sends message to and it captures image of meter reading. The DSP processor processes the captured image to get meter reading and sends it to the central server for billing and analysis. The software is already designed to generate automatic bill for received meter readings and will be sent to the registered consumer mobile number. The main advantage is accurate and automatic billing reduced man power requirement efficient water management etc., further to detect leakages in any zone AMR reading analysis can be used or leak noise correlators ground penetrating radar can be used Here DSP processor is used to speed up the operation[8].

This paper portrays about the PLC based automatic corporation water distribution system which helps us to distribute the water automatically according to the needs of the particular locality. The embedded controller already pre-programmed to do the operation. Solar energy is used as an alternative source for power supply operation of the PLC

unit. Float meter is used to measure accurate water supply. Specifically this research idea focuses the proper method of water distribution system using PLC and methodology required to protect the leakage of water and constant pressure maintenance while water distribution. A leakage sensor is used for that purpose. The PLC is used for monitoring and controlling the resistance .Flow meter is used to monitor the water supplying and it gives the signal to the pipe valve [9].

Water Wise is a stage for water distribution systems administrators that gives ongoing checking and choice help tools that can be utilized to help enhance framework the board and activity. A GPS with heartbeat for each second usefulness for time synchronization, and a 3G modem for information transmission The sensor hub is put away in a walled in area with its batteries also, mounted on a shaft. Pressure driven and water quality sensors are mounted on an incorporated multi-test that is embedded into the water pipe through an entryway valve. Water Wise hubs can be remotely and progressively designed to detect and transmit information in an assortment of ways [10].

III. PROPOSED METHOD

A. Block Diagram

The proposed system consists of arduino for controller and RF for communication. Thus from a main control unit we are controlling corporation water supply. This will be useful for peoples to get a proper water supply every day.

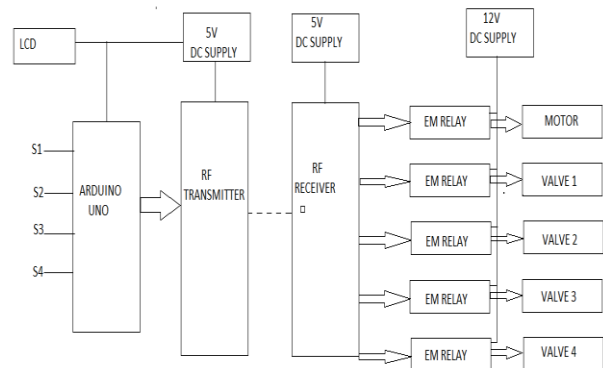

Fig. 1 Block diagram

B. Working

The transmitter is placed in the main control unit. It consists of the RF transmitter, Liquid Crystal Display (LCD) display, arduino and switches. Here the LCD, arduino, switches, RF module and other components need 5V supply for working, thus voltage regulators are used. The supply is given to the circuit initially. The receiver portion is near the water tank to control the valves. It consists of a RF receiver, a 240/12 v transformer, relay unit. The solenoid valve and the motor are connected with the relays. It is shown in fig.1. For supplying the circuit 9 v batteries are used. The arduino is already programmed as to work for our need. Thus when

the switch, which the valve to be opened is turned ON, the programmed signal will be given to the RF transmitter from arduino.

The transmitter transmits the data to the RF receiver. As the receiver receives the signal it will open the relevant valve to supply the water. After the set time the water supply gets automatically OFF. That is the valve will be closed through the relay. Thus the water supply is made simply by reducing the man power and also the wastage of water will be reduced.

C. RF Module

An RF module (radio frequency module) is a (usually) small electronic device used to transmit and/or receive radio signals between two devices. In an embedded system it is often desirable to communicate with another device wirelessly. The RF kit is shown in fig.2.

For many applications the medium of choice is RF since it does not require line of sight. RF communications incorporate a transmitter and a receiver. They are of various types and ranges. Some can transmit up to 500 feet. RF modules are widely used in electronic design owing to the difficulty of designing radio circuitry. RF modules are most often used in medium and low volume products for consumer applications such as garage door openers, wireless alarm or monitoring systems, industrial remote controls, smart sensor applications, and wireless home automation systems. They are sometimes used to replace older infra-red communication designs as they have the advantage of not requiring line-of-sight operation.



Fig. 2 RF MODULE

D. Arduino

Arduino UNO is an open-source microcontroller board based on the Microchip ATmega328P microcontroller and developed by Arduino. Arduino board designs use a variety of microprocessors and controllers. The boards are equipped with sets of digital and analog input/ output (I/O) pins that may be interfaced to various expansion boards or breadboards (shields) and other circuits. The boards feature serial communications interfaces, including Universal Serial Bus (USB) on some models, which are also used for loading programs from personal computers. The microcontrollers are typically programmed

using a dialect of features from the programming languages C and C++. In addition to using traditional compiler tool chains, the Arduino project provides an integrated development environment (IDE) based on the Processing language project.

E. Transformer

A transformer is a static electrical device that transfers electrical energy between two or more circuits. A varying current in one coil of the transformer produces a varying magnetic flux, which, in turn, induces a varying electromotive force across a second coil wound around the same core. Electrical energy can be transferred between the two coils, without a metallic connection between the two circuits. A 240/12V transformer is used in our project.

F. LCD

A liquid crystal display or LCD draws its definition from its name itself. Liquid crystal displays are super-thin technology display screen that are generally used in laptop computer screen, TVs, cell phones and portable video games. Light is projected from a lens on a layer of liquid crystal. This combination of colored light with the grayscale image of the crystal (formed as electric current flows through the crystal) forms the colored image, this image is then displayed on the screen. A 16*2 LCD display is used here for displaying the output is shown in fig.3



Fig. 3 LCD DISPLAY

G. Rectifier

A rectifier is an electrical device that converts alternating current (AC), which periodically reverses direction, to direct current (DC), which flows in only one direction. The process is known as rectification, since it "straightens" the direction of current. Rectifiers have many uses, but are often found serving as components of DC power supplies and high-voltage direct current power transmission systems.

H. Relay

A relay is an electrically operated switch. Relays are used where it is necessary to control a circuit by a separate low-power signal, or where several circuits must be controlled by one signal. A type of relay that can handle the high power required to directly control an electric motor or other loads is called a contactor. There are several relays used for different applications. We are using a 12 v relay for our circuit.



Fig. 4 RELAY

I. Solenoid Valve

A solenoid valve is an electromechanical device in which the solenoid uses an electric current to generate a magnetic field and thereby operate a mechanism which regulates the opening of fluid flow in a valve. The mechanism varies from linear action, plunger-type actuators to pivoted-armature actuators and rocker actuators. The valve can use a two-port design to regulate a flow or use a three or more port design to switch flows between ports. Multiple solenoid valves can be placed together on a manifold. Solenoids offer fast and safe switching, high reliability, long service life, good medium compatibility of the materials used, low control power and compact design.

IV. HARDWARE SETUP

The below figure shows the receiver and transmitter with the water supplying tank. It consists of a LCD display to display the output.



Fig. 5 Hardware setup



Fig. 6 Hardware running condition

The prototype figure shows the running condition of the valve 3. It is displayed in the LCD. After the programmed

time the valve closed automatically and the water supply will be stopped.

V. CONCLUSION

Water distribution, one of the major issues in developed and developing cities of our country. The corporation involves people appointed to control the flow and distribute the water based on the needs. But conflicts may be caused for various reasons. Automation of this water distribution may reduce the problem. Hence the proposed system was successfully implemented with Arduino that controls the supply of water based on the preprogrammed time setup. This System reduces the man power and financial needs given as salary for the distribution people. It also helps in providing uniform distribution and also reduces the wastage of water.

VI. FUTURE WORK

The Proposed system is implemented as prototype and tested. The same can be implemented as real-time application. The system is designed with time slots for particular area. We can use mobile apps for controlling the switch, thus we can access the system from anywhere.

REFERENCES

- [1] S Kusuma, *et al.*, "An IOT based Water Supply Monitoring and Controlling System", *Proceeding of International Research Journal of Engineering and Technology*, Vol. 5, No. 2, Feb-2018.
- [2] Prof. S.R. Kinge, *et al.*, "Automatic Water Distribution System", *Proceeding of Journal of Emerging Technologies and Innovative Research*, Vol. 4, No. 5, May 2017.
- [3] Sawsan Alshattawi, *et al.*, "Smart Water Distribution Management System Architecture Based on Internet of Things and Cloud Computing", *Proceeding of IEEE International Conference on New Trends in Computing Sciences*, 2017.
- [4] Auliantya Ayurin Putri, *et al.*, "3D Modelling and Visualization of Drinking Water Supply System Using 3D GIS", *Proceeding of IEEE 2017 7th International Annual Engineering Seminar on 2017*.
- [5] D. Valis, *et al.*, "Modelling Water Distribution Network Failures and Deterioration", *Proceeding of IEEE IEEM*, 2017.
- [6] Ling Fu, "Operation and Management of Drinking Water Supply Project in Rural Regions of Loess Plateau", *Proceeding of Scientific Research Foundation of Shandong Jiaotong University (No. Z201323)*, 2016.
- [7] Pratiksha Hattikatti, *et al.*, "PLC Controlled Water Distribution System", *Proceeding of International Journal of Advanced Research in Electrical & Electronics and Instrumentation Engineering*, Vol. 4, No. 5, May 2015
- [8] Mr. Santosh Gautam Kashid, *et al.*, "A Survey of Water Distribution System and New Approach to Intelligent Water Distribution System", *Proceeding of IEEE First International Conference on Networks & Soft Computing*, 2013.
- [9] P.Mukesh Aravind, *et al.*, "PLC Based Automatic Corporation Water Distribution System Using Solar Energy", *International Journal of Engineering Research & Technology*, Vol. 2, No. 12, Dec. 2013.
- [10] E Michael Allen, *et al.*, "Water Distribution System Monitoring and Decision Support Using a Wireless Sensor Network", *Proceeding of International Conference on Software Engineering*, 2013.