

Design and Simulation of Photovoltaic Array

Tithi Anish Antani¹, Ujjwal Kumar², Sindhu K. Bhat³ and Soumya Mishra⁴

^{1,2,3&4}Department of Electrical and Electronics Engineering, MVJ College of Engineering, Bengaluru, India

E-Mail: tithiantani@rediffmail.com, sammrat.kumar26@gmail.com, soumya.mishra@mvjce.edu.in, sindhubhat2015@gmail.com

(Received 15 April 2019; Revised 30 April 2019; Accepted 25 May 2019; Available online 2 June 2019)

Abstract - This paper illustrates a simple yet accurate method of modelling photovoltaic array. By adjusting the curve at three points: open circuit, maximum power, and short circuit, the parameter of the nonlinear equation can be determined. The information about these three major points is provided by all commercial array datasheets, using this data we can easily find the best I-V equation for the single-diode photovoltaic (PV) model. Adjusting the parameters of I-V equation, one can build a PV circuit model with any circuit simulator by using basic math blocks. The proposed circuit model and modeling method are useful for power electronics designers who need a simple, fast, accurate, and easy-to-use modeling method for using in simulations of PV systems.

Keywords: Array, Circuit, Equivalent, Model, Modeling, Photovoltaic (PV), Simulation

I. INTRODUCTION

The sunlight has enough energy to meet the needs of global demand if extracted in proper manner using photovoltaic panel. Sunlight is a great source of energy that can be converted into electricity using a photovoltaic (PV) system consisting of photovoltaic cells. The cells when connected in certain configuration form panel or modules as shown in Fig. 1. A group of panels further forms an array. This paper demonstrates modeling of photovoltaic modules or panels which are composed of several basic cells. At the terminals of a photovoltaic array the electricity available may directly be consumed by small loads such as lighting systems and DC motors. Electronic converters are required for some applications to process the electricity from the photovoltaic device. These converters can be used to control the power flow in the grid-connected systems and also to track the maximum power point (MPP) of the device, this can be done by regulating the voltage and current at load.

Factors like sunlight intensity, cloud cover, relative humidity and heat buildup contribute to the relative increase or decrease of the power production through PV panel. On the cloudy day the intensity of sunlight decreases since clouds reflects some of the rays and limits the amount of sunlight absorption by the panel. During summer as well when the temperature increases and reaches it's highest and starts heating up the setup quickly, the solar power reduces by 10% to 25% since too much heat increases conductivity of semiconductor making the charges balance and reducing the magnitude of the electric field. Also, if due to humidity in the surrounding the humidity penetrates the solar panel then the panel's overall performance drops resulting into less amount of power generated and in worst case scenario

it can permanently deteriorate the performance of modules in the panel.

To conduct an extensive study on electronic converters that can be used for PV systems, it is very much required to know how to model the PV devices that are the major source to the converters. The nonlinear I-V characteristics of PV modules have to be adjusted to obtain the maximum energy from sunlight. The mathematical model of the photovoltaic array can be used to study the dynamic analysis of converters, in the study of maximum power point tracking (MPPT) algorithms and mainly to simulate the photovoltaic system and its components using simulators.

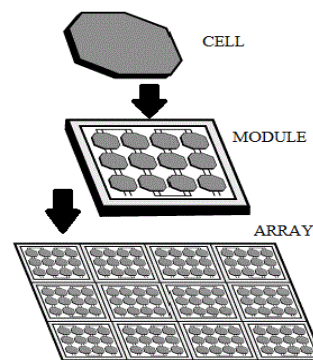

Fig. 1 Photovoltaic Hierarchy

Progressing through this paper, one would see that by using basic equations modeling of PV system is implemented. This paper does not provide in dept analysis of the PV phenomenon, yet an overview is given for reference and better understanding of the concepts being used while simulating the model.

II. HOW A PV CELL WORKS

A semiconductor diode having p-n junction exposed to light, capable of generating energy from the light that strikes the surface is called photovoltaic cell (PV). These PV cells are made up of several types of semiconductors like mono crystalline and polycrystalline silicon, using different processes of manufacturing. A thin or bulky layer of silicon in silicon PV cell film is connected to electrical terminals. Generation of charges takes place when sunlight strikes a thin metallic grid like surface. In accordance to irradiation intensity of light the current is generated. For this purpose, the doping of one of the sides of thin layer of p-n

junction is done. Photovoltaic phenomenon occurs at a certain condition and that is the light incident in the surface of the cell should have sufficient energy to detach the covalent electron of the cell, so the light of threshold wavelength is necessary for the generation of electric energy.

The empirical data is provided by the manufacturer of the PV device, which can be further used in mathematical equations for the modeling of PV device I-V curve. Also, some manufacturers may provide the I-V curve obtained experimentally for different operating conditions.

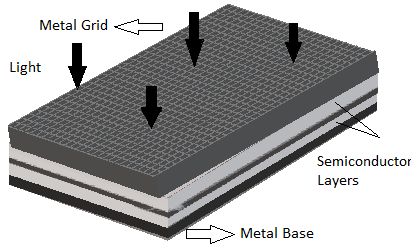

Fig. 2 Structure of a PV cell

III. MODELING OF PHOTOVOLTAIC ARRAYS

A Photovoltaic (PV) cell is composed of p-n junction diode which is the ideal part of PV cell but in practical there is some internal resistance is offered when there are several cells connected in series -parallel configuration to forming a practical PV device, the same is depicted in Fig. 3.

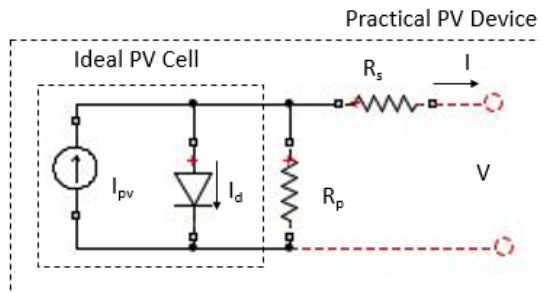

Fig. 3 Single diode representation of the practical PV cell

The base equation for the modeling of PV cell that describes the ideal I-V characteristic of photovoltaic cell is given below as follows:

$$I = I_{PV,cell} - I_d \quad (1)$$

$$I = I_{PV,cell} - I_{0,cell} \left[e^{\left(\frac{qV}{akT}\right)} - 1 \right] \quad (2)$$

Where $I_{pv,cell}$ is the generated current by the sunlight incident on the surface of the panel which is directly proportional to the Sun irradiation, I_d is the Shockley diode equation which is obtained using following parameters: $I_{0,cell}$, q , k , T , a and V . Here $I_{0,cell}$ is the reverse saturation or

leakage current of the diode, q is the electron charge having value of $1.60217646 \times 10^{-19} C$, k is the Boltzmann constant with the value of $1.3806503 \times 10^{-23} J/K$, T (in Kelvin) is the temperature of the p-n junction, and a is the diode ideality constant.

The practical PV array cannot be represented by the equation used to represent elementary PV cell. The PV array in practical is composed of several PV cells connected in series parallel configuration which adds up few more parameters to the base equation that we considered previously.

$$I = I_{PV} - I_0 \left[e^{\left(\frac{V+R_s I}{V_t a}\right)} - 1 \right] - \frac{V + R_s I}{R_p} \quad (3)$$

where I_{pv} and I_0 as mentioned previously are the photovoltaic (PV) and saturation currents, respectively, of the array.

$$V_t = \frac{N_s k T}{q} \quad (4)$$

Here V_t is the thermal voltage of the array with N_s cells connected in series. Connections of cells in series and parallel makes difference to its voltage and current values respectively, by increasing or decreasing the value of the corresponding parameter. Considering the array that is composed of N_p cells connected in parallel then the saturation current can be expressed as $I_{pv} = I_{pv,cell} N_p$. R_s and R_p are the equivalent series and parallel resistance respectively.

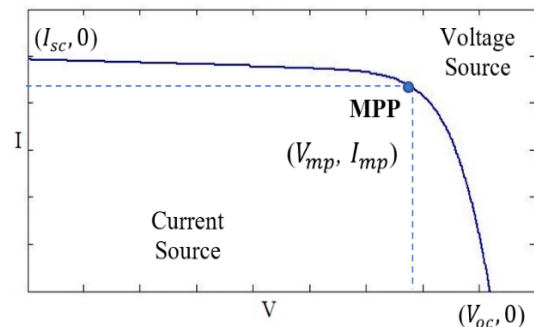

Fig. 4 Characteristic I-V curve of a practical photovoltaic device highlighting three points: short circuit (0, Isc), maximum power point (Vmp, Imp) and open-circuit (Voc, 0).

This equation depicts the I-V curve, where three major highlighted points are: short circuit, MPP and open circuit. In practical scenario looking at the physical aspect of the PV array, after modeling single cell we connect several individual cells in series parallel configuring. Though for the purpose of simulation one may only consider the number of cells that are connected in series as well as parallel instead of simulating single cell and then replicating

them and connecting them in series-parallel fashion according to the requirement. The previous equation is altered in a way where N_p and N_s is included in the equation.

Arrays that are large are composed of several panels, that are modeled in the same way, provided that the equivalent parameters (short-circuit current, open-circuit voltage) are properly inserted in the modeling process. The corresponding equivalent parameters of the association are obtained, as a result. The experimental data is available only for commercial low-power modules and that is the reason why this paper has been chosen to deal with small arrays.

In Fig. 5(a) one can observe that several identical modules are connected in series which together form an array. As discussed before increase in N_{ser} is directly proportional to increase in output voltage, yet current remains unchanged. Also, the equivalent series and parallel resistance is also directly proportional to the number of modules.

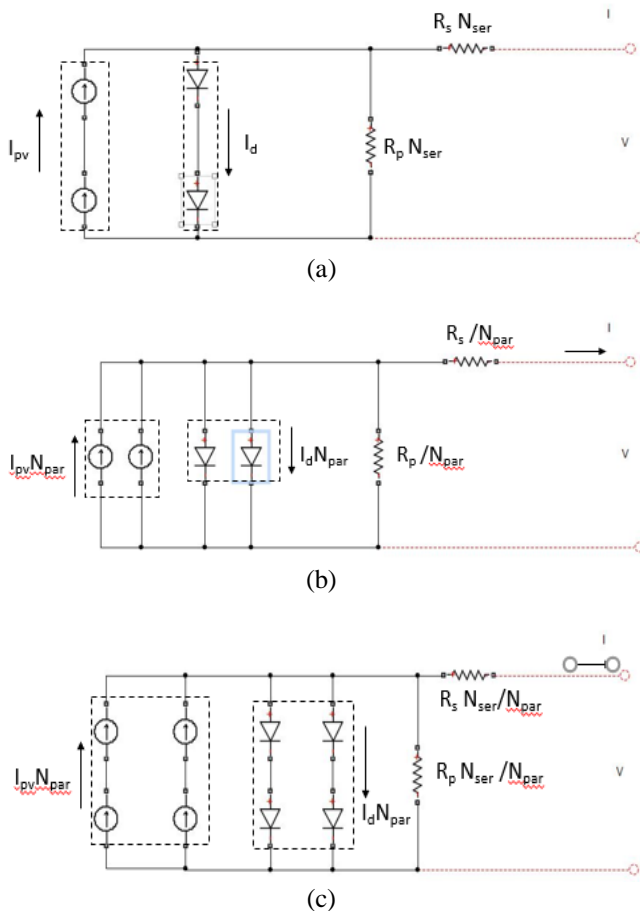

Fig. 5 (a) Array of series connected cells (b) Array of parallel connected cells (c) Array of series and parallel connected cells

Similarly, in Fig. 5(b) it is shown that several identical modules are connected in parallel which together form an array, which results in increased output current and the output voltage remains same. The number of parallel modules is inversely proportional to equivalent series parallel configuration of cells.

In Fig. 5(c) it shown that several modules connected in series and parallel configuration forming a photovoltaic array. The following equivalent I-V equation for any given array is formed by $N_{ser} \times N_{par}$ identical modules:

$$I = I_{pv} N_{par} - I_o N_{par} \left[e^{\left(\frac{V + R_s \left(\frac{N_{ser}}{N_{par}} \right) I}{V_{t,n} N_{ser}} \right)} - 1 \right] - \frac{V + R_s \left(\frac{N_{ser}}{N_{par}} \right) I}{R_p \left(\frac{N_{ser}}{N_{par}} \right)} \quad (5)$$

The basic equation of the photovoltaic cell as discussed above has several parameters that has to be calculated separately and then put into the base equation. These separately calculated parameter forms a sub-system own its own which gives an output which is fed to the system formed with the base equation.

$$I_{pv} = (I_{pv,n} + K_I \Delta T) \frac{G}{G_n} \quad (6)$$

So, taking the first parameter into consideration that is I_{pv} which comprises of $I_{pv,n}$ that is the light-generated current at the nominal condition, K_I is current co-efficient, $\Delta T = T - T_n$ where T and T_n are the actual and nominal temperatures in kelvin, G is the irradiation on the device surface and G_n is the nominal irradiation in W/m^2

The diode saturation current I_o is another parameter that is expressed in accordance to temperature by:

$$I_o = I_{o,n} \left(\frac{T}{T_n} \right)^3 e^{\left[\frac{qE_g}{ak} \left(\frac{1}{T_n} - \frac{1}{T} \right) \right]} \quad (7)$$

where E_g is the bandgap energy of the semiconductor ($E_g \approx 1.12$ eV for the polycrystalline Si at 25 °C, and $I_{o,n}$ is the nominal saturation current:

$$I_{o,n} = \frac{I_{sc,n}}{e^{\left(\frac{V_{oc,n}}{n a V_{t,n}} \right)} - 1} \quad (8)$$

Here $V_{t,n}$ is the thermal voltage of N_s series-connected cells at the nominal temperature T_n .

The saturation current density of the semiconductor J_o and the effective area of the cells are the two parameters on which saturation current I_o of the PV cell forming the device depends upon. Furthermore, the current density J_o has its dependency on the intrinsic characteristics of the PV cell which further depends on parameters such as the coefficient of diffusion of electrons in the semiconductor device, the lifespan of minority carriers and many others, though all this detailed information is not available in the datasheet provided for commercial uses. So, instead one can obtain the nominal saturation current $J_{o,n}$ from the equation (8) which is obtained by evaluating equation (3) at nominal

open circuit conditions where $V = V_{oc,n}$, $I=0$ and $I_{pv} \approx I_{sc,n}$.

The diode constant a value maybe be chosen arbitrarily. The range in which value of a lies is $1 \leq a \leq 1.5$ and also other parameters of I-V model affects the choice of the value of a. Since a expresses the degree of identity of the diode and it is completely empirical in nature, to adjust the model any initial value of a can be considered.

Later for the fitting purpose the value of a can be modified if necessary. The curvature of the I-V characteristics and the accuracy of the model are affected by varying the value of this constant and adjusting it for the best outcomes.

Going further into modeling and improving the equations to get more accurate result one can use the below given below equation:

$$I_o = \frac{I_{sc,n} + K_I \Delta T}{e^{\left(\frac{V_{oc,n} + K_V \Delta T}{aV_t}\right)} - 1} \quad (9)$$

The above modification is done to match the open circuit voltages of the model, with the data obtained experimentally for quite a large of temperatures. By including the current and voltage co-efficient K_I and K_V we have obtained the improved version of equation (8). In Eq. (9) a different approach is proposed to express the dependence of I_o on the temperature so that the net effect of temperature is linear variation of open-circuit voltage in accordance to the practical voltage/temperature co-efficient. By improving the equation, one may simplify the model and eliminate the chances of error at the vicinities of the open-circuit voltages.

In this paper the reference datasheet taken is of Kyocera KC200GT and the data as used in the paper is mentioned as below in Table I and Table II. The characteristic data mentioned in the table is used in the equations used for modeling PV array. The data provided is commercially available with all the PV array for the reference.

IV. ADJUSTING THE MODEL

The simulation in this paper has been done in accordance to model KC200GT SOLAR ARRAY AT 25 °C and one can obtained a pre-determined parameter as a part of datasheet using those parameters, other several parameters can be calculated. Though R_s and R_p are two such parameter that are remaining unknown so for the calculation one can adjust and obtain the appropriate value that gives accurate results in several iterations.

To determine the value of these parameters the mathematical formula can be used which uses all the experimental data mentioned in the datasheet provided. There is only one set of value for these.

TABLE I PARAMETERS MENTIONED IN DATASHEET OF THE KC200GT PV ARRAY AT 25 °C, 1000 W/M²

I_{mp}	7.61A
V_{mp}	26.3V
$P_{max,e}$	200.143 W
I_{sc}	8.21A
V_{oc}	32.9V
K_V	-0.1230 V/K
K_I	0.0032 A/K
N_s	54

TABLE II PARAMETERS MENTIONED IN DATASHEET OF THE KC200GT PV ARRAY AT 25 °C, 1000 W/M²

$P_{max,m}$	200.143 W
$I_{o,n}$	-0.1230 V/K
I_{pv}	0.0032 A/K
R_p	415.405Ω
R_s	0.221Ω
a	1.3

Two parameters that fits to give an outcome where the $P_{max,m} = P_{max,e} = V_{mp} I_{mp}$ that is the maximum power calculated from the datasheet is equal to the maximum power at MPP.

So, for the purpose of obtaining value of R_s and R_p one can solve the equation (10) and (11) given below:

$$P_{max,n} = V_{mp} \left\{ I_{PV} - I_o \left(e^{\left(\frac{q[V_{mp} + R_s I_{mp}]}{kTaN_s}\right)} - 1 \right) - \frac{V_{mp} + R_s I_{mp}}{R_p} \right\} \quad (10)$$

$$P_{max,n} = P_{max,e} \quad (11)$$

$$R_p = \frac{V_{mp} (V_{mp} + I_{mp} R_s)}{P_{max,m}} \quad (12)$$

So, looking at the equation (10) and (11) one can see how R_p is dependent on R_s value and as R_s changes the R_p value will be changed.

V. SIMULATION RESULTS

Simulation of the photovoltaic device using the above-mentioned equation for the eq. (5) is as follows.

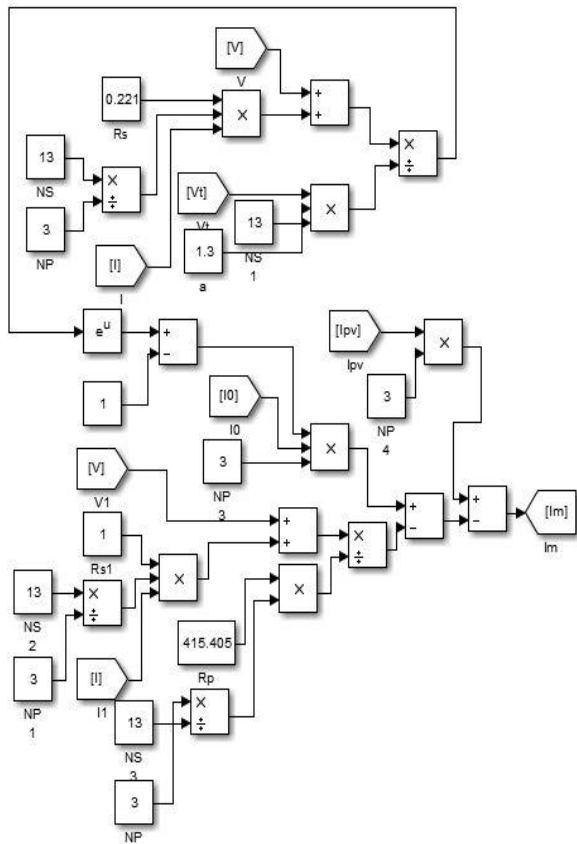

Fig. 6 Simulation for equation (5)

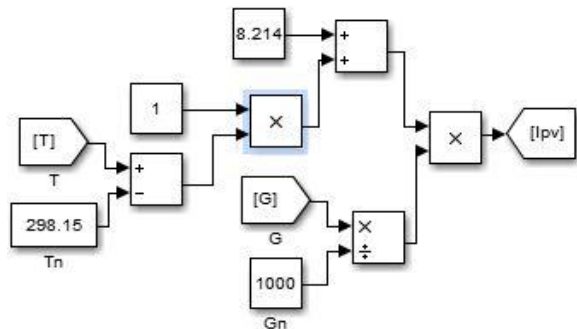

Fig. 7 Simulation for equation (4)

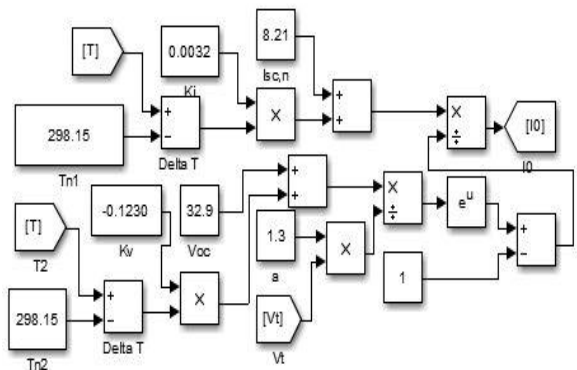

Fig. 8 Simulation for equation (9)

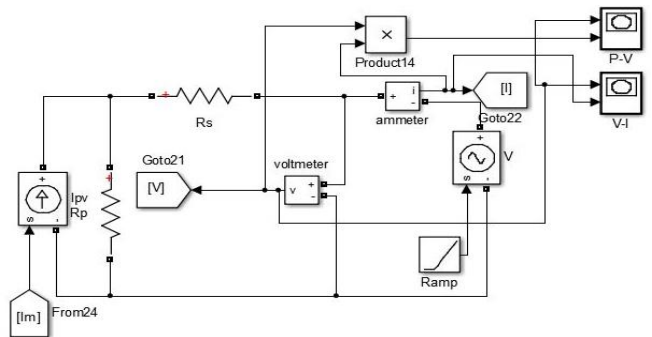

Fig. 9 Photovoltaic Array Simulation

The P-V array which has been simulated with the reference of an equivalent circuit model shown in fig(3). Among several circuit simulator, MATLAB has been used for the circuit simulation, the current value I_m is computed by the functional block which has V, I, I_0 and I_{pv} as in inputs. I_0 is calculated from (8). The current value is calculated numerically by solving I-V equation and for each $V \& I$ value satisfies the I-V equation. The Fig. 6,7 and 8, represents the functional block for the calculation of I_m, I_{pv} and I_0 respectively That has been used for the photovoltaic array simulation in fig (9). The desired simulation output for the PV array has been showed in Fig(10),(11),(12) and (13).

Fig. 10 Represents the P-V characteristics for the the simulated PV array for the different value of series resistance (R_s).

Fig. 11 Represents the V-I characteristics for the simulated PV array that has maximum voltage of 800 V and current of 25 A.

Fig. 12 Represents the V-I characteristics for the simulated PV array at different temperatures which depicts the decrease in voltage with increase in temperature.

Fig. 13 Represents the V-I characteristics for the simulated PV array at different irradiance which depicts the decrease in current with decrease in irradiance.

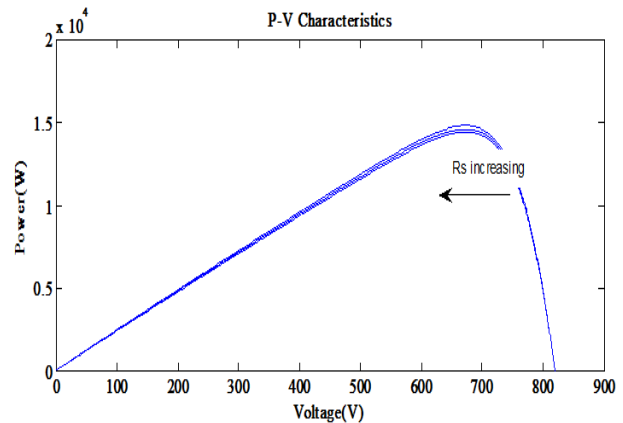

Fig. 10 P-V Characteristics for varying R_s

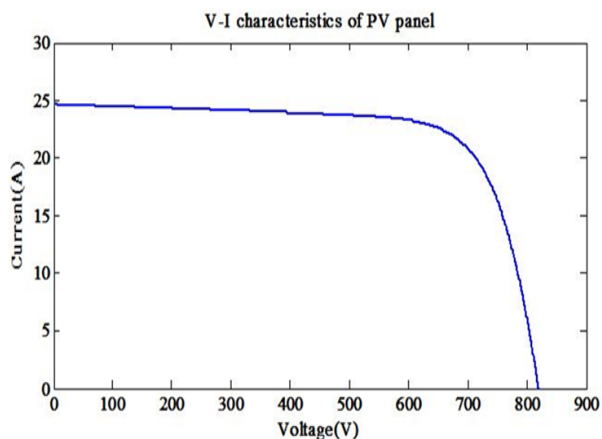

Fig. 11 V-I Characteristics Graph

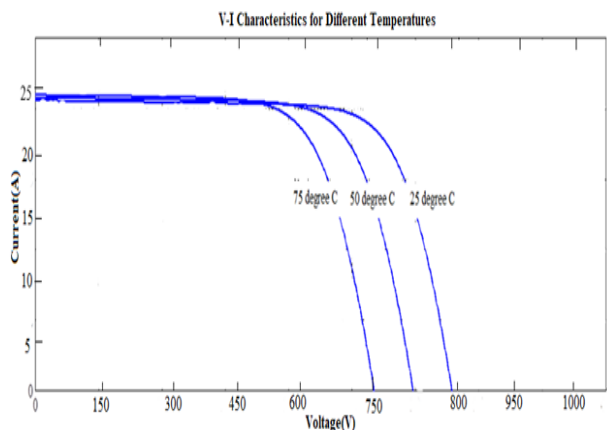

Fig. 12 V-I Characteristics for varying Temperature

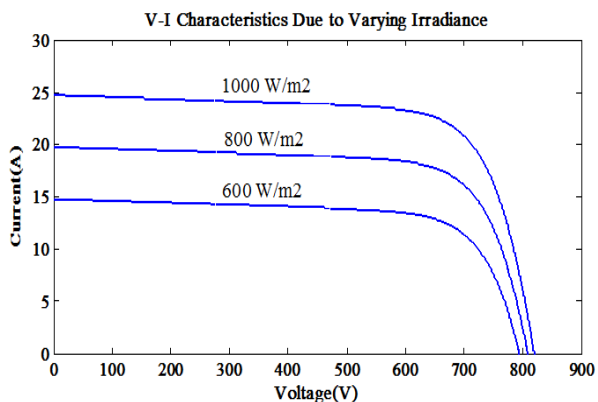

Fig. 13 V-I Characteristics Graph for changing irradiation value

VI. CONCLUSION

In this paper the major focus point has been to model a PV cell and then on a larger scale modeling PV device using

mathematical equations. The equations used throughout the paper to do the modeling are derived from the practical scenario of PV cell considering the parameters that actually affects the output of PV cell. Here all the parameter that has been used are generally available in datasheet of the PV array available commercially such as open circuit current, open circuit voltage, maximum power output, current/temperature and voltage/temperature coefficient. This paper has proposed the simplest and most accurate form of modeling PV array, where all the parameters have been tried to fit in to satisfy the MPP, so as to obtain the maximum output at all the given time. Also, the simulated block model present in the paper gives a clear idea of the simulation model that is obtained from the expression mentioned in the paper. Obtaining graphs by changing several parameters which has drastic impact on the power obtained from PV device, several characteristics can be extracted. Looking at those characteristics one can easily know the changes in environmental conditions.

REFERENCES

- [1] W. Xiao, W. G. Dunford, and A. Capel, "A novel modeling method for photovoltaic cells", in *Proc. IEEE 35th Annu. Power Electron. Spec. Conf. (PESC)*, Vol. 3, pp. 1950-1956, 2004.
- [2] M. A. Vitorino, L. V. Hartmann, A. M. N. Lima, and M. B. R. Correa, "Using the model of the solar cell for determining the maximum power point of photovoltaic systems", in *Proc. Eur. Conf. Power Electron. Appl.*, pp. 1-10, 2007.
- [3] D. Dondi, D. Brunelli, L. Benini, P. Pavan, A. Bertacchini, and L. Larcher, "Photovoltaic cell modeling for solar energy powered sensor networks", in *Proc. 2nd Int. Workshop Adv. Sens. Interface (IWASI)*, 2007, pp. 1-6.
- [4] H. Patel, and V. Agarwal, "MATLAB-based modeling to study the effects of partial shading on PV array characteristics", *IEEE Trans. Energy Convers.*, Vol. 23, No. 1, pp. 302-310, Mar. 2008.
- [5] M. C. Glass, "Improved solar array power point model with SPICE realization", in *Proc. 31st Intersoc. Energy Convers. Eng. Conf. (IECEC)*, Vol. 1, pp. 286-291, Aug. 1996.
- [6] A. Kajihara, and A. T. Harakawa, "Model of photovoltaic cell circuits under partial shading", in *Proc. IEEE Int. Conf. Ind. Technol. (ICIT)*, pp. 866-870, 2005.
- [7] Marcelo Gradella Villalva, Jonas Rafael Gazoli, and Ernesto Ruppert Filho "Modeling and circuit-based simulation of photovoltaic arrays", in *Proc. IEEE Int. Conf.*, pp 1244-1254.
- [8] KC200GT high efficiency multicrystal photovoltaic module datasheet
- [9] A. Kajihara, and A. T. Harakawa, "Model of photovoltaic cell circuits under partial shading", in *Proc. IEEE Int. Conf. Ind. Technol. (ICIT)*, pp. 866-870, 2005.
- [10] Q. Kou, S. A. Klein, and W. A. Beckman, "A method for estimating the long-term performance of direct-coupled PV pumping systems", *Solar Energy.*, Vol. 64, No. 1-3, pp. 33-40, Sep. 1998.
- [11] T. F. Elshatter, M. T. Elhagry, E. M. Abou-Elzahab, and A. A. T. Elkousy, "Fuzzy modeling of photovoltaic panel equivalent circuit", in *Proc. Conf. Record 28th IEEE Photovoltaic Spec. Conf.*, pp. 1656-1659, 2000.