

A Review on Application of Soft Computing Techniques for Load Shedding in Power Systems

Nagesh H.¹ and R. S. Shivakumara Aradhya²

¹Assistant Professor, ²Professor, Department of Electrical and Electronics Engineering,
Acharya Institute of Technology, Soladevanahalli, Bengaluru, Karnataka, India
E-Mail: hnagesh99@gmail.com

(Received 31 August 2018; Revised 23 September 2018; Accepted 15 October 2018; Available online 21 October 2018)

Abstract - In power systems, system frequency decreases if load exceeds generation and increases when power generation is greater than load demand. Load shedding is highly required in power systems to stabilize frequency in electrical power systems. Though conventional load shedding techniques are being used in many power system applications, soft computing techniques such as artificial neural networks (ANNs), fuzzy logic, genetic algorithm and particle swarm optimization have been presented by many researchers to provide optimum load shedding. However, there are many problems associated with machine learning based control techniques in real time. In this work, the utilization of soft computing algorithms and its benefits and drawbacks are discussed. A comprehensive survey is presented about the soft computing based load shedding and comparison is made among these techniques and conventional techniques. Neural network based learning rule is applied with back propagation network to minimize the error. In fuzzy based technique, load shedding position at each node was predetermined by applying certain fuzzy rules. Genetic algorithm and particle swarm optimization are robust and applied to solve many nonlinear and multi-objective problems. ANN and fuzzy logic are combined to build an adaptive neuro fuzzy inference system to provide accurate load shedding.

Keywords: Load Shedding, Frequency Stabilization, Soft Computing, Fuzzy Logic Control, Neural Networks, Machine Learning

1. INTRODUCTION

Power system blackouts happen in many areas due to natural reasons or technical reasons. The natural reasons are tree falling on stormy weather, transmission pole falling due to accident. Technical reasons are damaged distribution wires, frequency instability issues and transmission line overloading. The blackouts have serious impacts in healthcare system maintenance and internet breakdown in important urban areas. The main reason for blackout is the voltage instability due to transmission line overloading at some specific instances [5]. These voltage instability issues have the cascading effect on power outages and power system blackouts.

Electricity generation and consumption need to be balanced continuously, but it is impossible due to the varying demand. The varying demand leads to power system frequency increase or decrease [6]. To address the problems due to imbalance, overall demand is lowered by cutting back the supply voltage to prevent power outages and equipment damage. Load shedding is intended in power

systems to shed some of the electrical load so that damage to the power system could be avoided. Under frequency load shedding scheme is applied to provide the frequency stability, but there is a requirement for an effective scheme to provide optimum load shedding. The conventional load shedding techniques like under frequency and under voltage shedding schemes are being used in many power system applications, but optimum load shedding is not obtained in many applications [2].

Machine learning based techniques provide the option of training the system and make them to learn from the experience [1]. These intelligent machine learning based computational intelligent techniques are widely known as soft computing methods. Soft computing techniques such as artificial neural networks (ANNs), fuzzy logic, genetic algorithm and particle swarm optimization have been presented by many researchers to provide optimum load shedding [11]. Though these techniques are attractive in many engineering applications and power systems, there are many problems associated with machine learning based control techniques in real time. This paper provides the application of different soft computing algorithms in achieving optimum load shedding. The benefits and drawbacks of all these techniques are discussed in detail and compared.

Energy production is a key in the development of any country and it needs to be environment friendly. Recently the developed and developing countries focus more on electricity generation from renewable energy sources [4]. The renewable energy sources like wind, water, solar and sea waves are used to reduce the carbon emission. Keeping in view of the advantages of renewable energy and environment friendly nature, distributed generation gained a huge attention among industrialists and researchers [15]. In distributed generation with renewable sources, it is necessary to take care of power quality, stability and acceptance level of voltage and amplitude. Neural network based learning rule is applied with back propagation network and counter to minimize the error. In fuzzy logic based load shedding, load shedding position can be predetermined by applying fuzzy membership functions and certain fuzzy rules. To improve the load shedding performance of neural network and fuzzy logic based methods, neuro fuzzy techniques are applied, widely known

as adaptive neuro fuzzy inference system. Optimization techniques are used in many control applications and communication systems for extracting optimum performance of systems. Genetic algorithm and particle swarm optimization are robust and applied to solve many nonlinear and multi-objective problems.

This paper comprises of five chapters that includes this introductory section. Section 2 discusses the conventional and unconventional load shedding techniques. Section 3 presents the different soft computing techniques which are proposed by researchers in various scenarios. The merits and drawbacks of soft computing techniques are discussed in Section 5. Finally, the work is concluded in Section 5.

II. LOAD SHEDDING TECHNIQUES

Load shedding techniques are useful to restore the frequency to the admissible limits when the stable frequency cannot be maintained in the power system due to imbalance in power generation and distribution. Both conventional and adaptive techniques are applied in load shedding in many real time applications [10]. Though conventional methods are well tested in many situations, there is a lot of scope for improving these techniques in the form of adaptive and soft computing based load shedding. In this review, machine learning based intelligent computing or soft computing techniques are focused. Figure 1 shows the different types of load shedding available in the literature [12-13].

In general, load shedding techniques are classified into three major categories based on conventional and unconventional techniques. They are

1. Conventional load shedding
2. Adaptive load shedding
3. Soft computing based load shedding

Conventional techniques are again categorized into under frequency and under voltage load shedding. Soft computing based techniques are based on machine learning based methods and optimization techniques. Some of the widely known soft computing techniques are artificial neural networks, fuzzy logic, adaptive neuro fuzzy inference system, genetic algorithm and particle swarm optimization.

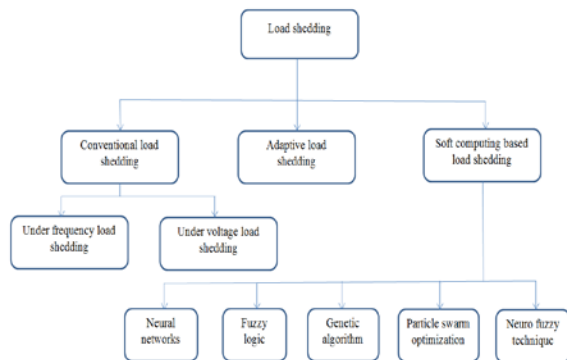

Fig. 1 Types of load shedding

A. Soft Computing Techniques for Load Shedding

Machine learning based algorithms and optimization techniques are applied in many applications such as industry plant control, stabilization, error control and transmission systems [7-8]. The five important soft computing techniques discussed in section 2 are elaborated in detail in the section.

III. ARTIFICIAL NEURAL NETWORKS (ANNs)

Neural networks are composed of various functional units that are operated in parallel. Neural networks are trained to perform a specific function by modifying the weights or coefficient values between elements. Neural networks are trained repeatedly until the network output matches the desired target value. The number of training performed in the neural network is known as epochs. Back propagation is one of the popular neural learning algorithm that can be used in multilayer feed forward networks. Figure 2 depicts the neural network structure that comprises of input layer, hidden layer and output layer. Input vectors and the corresponding output vectors are used to train a network until it can approximate a function defined by the user.

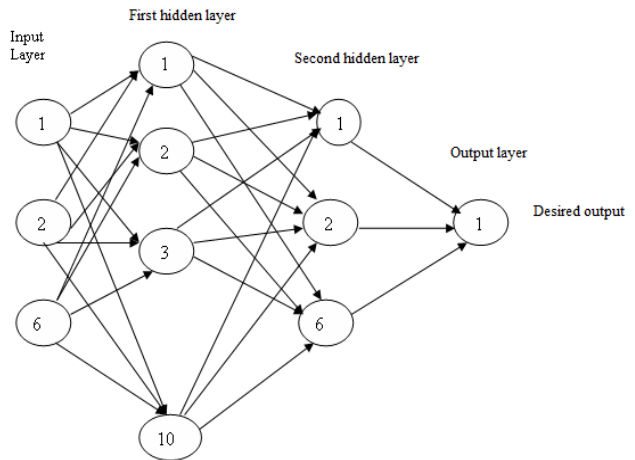

Fig. 2 Neural network structure for training

Neural network structures are utilized in power system applications for frequency control, voltage stability and load forecasting [9, 14]. In load shedding applications, generated power and load demand are considered as input and amount of load shedding as output. Though ANN provides accurate results for trained data, it fails in many situations while applying varying cases.

A. Fuzzy logic technique

Fuzzy logic techniques are applied in many power system applications by utilizing fuzzy membership and fuzzy inference system. Fuzzy inference is the process of formulating the mapping from a given input to an output using fuzzy logic. In practice, the weighted average operator is occasionally replaced with the weighted sum operator to reduce computation further mainly in the training of a fuzzy inference system. Fuzzy logic control is used to model a complex mathematical operation.

The process of identifying a fuzzy model is generally divided into the identification of the premises and that of the consequences. And each of the identifying processes is divided into the identification of the structures and the parameters. The structures of a fuzzy model mean the combination of the input variables and the number of the membership functions in the premises and in the consequences. Sugeno's method finds the best fuzzy model by repeating the followings

1. The selection of the structures in the premises,
2. The identification of the parameters in the premises,
3. The selection of the structures in the consequences, and
4. The identification of the parameters in the consequences.

The drawback in this type of load shedding is that identifying process takes more time. Our experience tells us that the characteristics of a fuzzy model depend heavily on the structures rather than on the parameters of the membership functions. The selection of the structures is first done once in the process.

B. Adaptive Neuro Fuzzy Inference System (ANFIS)

ANFIS serve as a basis for constructing a set of fuzzy ‘if-then’ rules with appropriate membership function to generate the stipulated input-output pairs. ANFIS considers an initial fuzzy inference (FIS) system and tuning it with a back propagation algorithm based on the compilation of input-output data. The basic structure of a fuzzy inference system comprises of three conceptual components, shown in figure 3: a rule base, which contains a set of fuzzy rules; a database, which defines the membership functions used in the fuzzy rules; and a reasoning mechanism, which performs the inference procedure based on the rules and to derive a reasonable output. The ANFIS is a fuzzy inference system implemented in the framework of adaptive networks [16]. To describe the ANFIS architecture, two fuzzy if-then rules based on a first order Sugeno model are considered

- Rule 1:* If (x is A1) and (y is B1) then (f1 = p1x+q1 y +r1).
Rule 2: If (x is A2) and (y is B2) then (f2 = p2x+q2 y +r2).

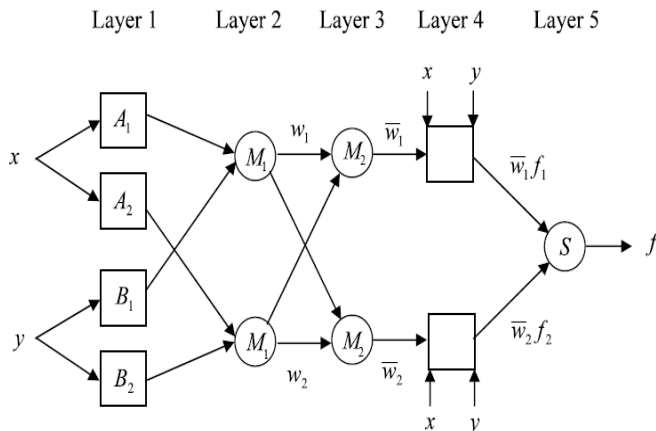

Fig. 3 ANFIS network

Here \$x\$ and \$y\$ are the inputs, \$A_1, A_2, B_1\$ and \$B_2\$ are the fuzzy sets, \$f_i\$ are the outputs within the fuzzy region specified by the fuzzy rule, \$p_i\$, \$q_i\$ and \$r_i\$ are the design parameters that are determined during the training process. The ANFIS architecture to implement these two rules is shown in Fig. 2, in which a circle indicates a fixed node, whereas a square indicates an adaptive node. In the first layer, all the nodes are adaptive nodes. The output of layer 1 is the fuzzy membership grade of the inputs, which is given by

$$O_i^1 = \mu_{A_i A_2}(x) \tag{1}$$

where \$\mu_{A_i A_2}(x)\$ is membership function

In this work we have opted bell shaped MF with maximum equal to 1 and minimum equal to 0, such as

$$\mu_{A_i A_2}(x) = \frac{1}{1 + \left\{ \left(\frac{x - c_i}{a_i} \right)^2 \right\}^{b_i}} \tag{2}$$

where \$a_i\$, \$b_i\$ and \$c_i\$ are the parameters of the membership function, governing the bell shaped functions accordingly. In the second layer, the nodes \$M_1\$ are fixed nodes, operate as simple multipliers. The outputs of this layer can be represented as

$$O_i^2 = w_i = \mu_{A_i}(x) \cdot \mu_{B_i}(y), \quad i=1, 2, \tag{3}$$

Each node output represents the firing strength of a rule. In the third layer, the nodes are also fixed nodes. They are labeled with \$M_2\$, signifying that they play a normalization role to the firing strengths from the previous layer. The outputs of this layer can be represented as

$$O_i^3 = w_i^* = \frac{w_i}{w_1 + w_2}, \quad i=1, 2, \tag{4}$$

which are known as the normalized firing strengths.

Every node in the fourth layer is adaptive node with node function,

$$O_i^4 = w_i^*(p_i x + q_i y + r_i) \quad i=1, 2. \tag{5}$$

The summation node ‘S’ in the fifth layer computes the overall output as the summation of all incoming signals.

It can be observed that there are two adaptive layers in this ANFIS architecture, namely the first layer and the fourth layer. In the first layer, there are three modifiable parameters \$\{a_i, b_i, c_i\}\$, which are related to the input MFs. In the fourth layer, there are also three modifiable parameters \$\{p_i, q_i, r_i\}\$, pertaining to the first order polynomial. These parameters are referred to as consequent parameters.

The task of the learning algorithm for this architecture is to tune all the variable parameters, namely $\{a_i, b_i, c_i\}$ and $\{p_i, q_i, r_i\}$, to make the ANFIS output match the training data. When the premise parameters a_i, b_i and c_i of the MF are fixed, the output of the ANFIS model can be written as

$$f = w_1^* f_1 + w_2^* f_2 \tag{6}$$

Substituting the fuzzy if-then rules into Eq. (6), it becomes

$$f = (w_1^* x) p_1 + (w_1^* y) q_1 + (w_1^* r_1) + (w_2^* x) p_2 + (w_2^* y) q_2 + (w_2^* r_2) \tag{7}$$

which is a linear combination of the modifiable consequent parameters p_1, q_1, r_1, p_2, q_2 and r_2 .

V. COMPARISON OF SOFT COMPUTING TECHNIQUES

Various soft computing techniques have been applied for load shedding that is discussed in detail. The merits and drawbacks of those techniques are assessed and comparison is made in Table I. From the Table I, it is observed that neuro fuzzy based ANFIS performs better than other soft computing techniques, since it combines the advantages of both ANN and fuzzy logic concept [3].

TABLE I COMPARISON OF SOFT COMPUTING TECHNIQUES FOR LOAD SHEDDING

Technique	Advantages	Drawbacks
ANN	Optimum result is possible for trained data	It fails when dealing with unknown data
Fuzzy logic	Fuzzy logic can be applied for data of any size	Prior knowledge is require to get optimum performance
ANFIS	Accurate load shedding is possible	Performance depends on type of FLC
Genetic Algorithm	Applicable for nonlinear and multi objective problem	Time consuming

V. CONCLUSION

Soft computing based load shedding and conventional techniques are presented in this survey paper. The merits and associated problems in each of these techniques have been presented and elaborated in detail. In Neural network based load shedding, back propagation network is utilized to minimize the error. In fuzzy based technique, load shedding position at each node was predetermined by applying certain fuzzy rules. Genetic algorithm and particle swarm optimization are also discussed to overcome the existing issues in load shedding. Since accurate load shedding is crucial in many real time applications, neuro fuzzy technique can be preferred that utilized the advantages of

both the neural network and fuzzy logic concepts. Though the survey gives an idea about the load shedding schemes, it is required to apply in real time scenario to conclude the best possible load shedding scheme for power systems.

REFERENCES

- [1] G. Arnold, "Intelligent Systems: A New Industrial Revolution [Viewpoint]", *IEEE Electrification Magazine*, Vol. 4, No. 1, pp. 64–63, 2016.
- [2] N. N. A. Bakar, M. Y. Hassan, M. F. Sulaima, M. N. I. M. Nasir, and A. Khamis, "Microgrid and load shedding scheme during islanded mode: A review", *Renewable and Sustainable Energy Reviews*, Vol. 71, pp. 161–169, 2017.
- [3] A. Bikas, E. Voumvoulakis, and N. Hatziaargyriou, "Neuro-Fuzzy Decision Trees for Dynamic Security Control of Power Systems", *15th International Conference on Intelligent System Applications to Power Systems*, 2009.
- [4] Y. Cao, X. Wang, Y. Li, Y. Tan, J. Xing, and R. Fan, "A comprehensive study on low-carbon impact of distributed generations on regional power grids: A case of Jiangxi provincial power grid in China", *Renewable and Sustainable Energy Reviews*, Vol. 53, pp. 766–778, 2016.
- [5] F. Conteh, S. Tobaru, M. E. Lotfy, A. Yona, and T. Senjyu, "An effective Load shedding technique for micro-grids using artificial neural network and adaptive neuro-fuzzy inference system", *AIMS Energy*, Vol. 5, No. 5, pp. 814–837, 2017.
- [6] A. A. Girgis and S. Mathure, "Application of active power sensitivity to frequency and voltage variations on load shedding", *Electric Power Systems Research*, Vol. 80, No. 3, pp. 306–310, 2010.
- [7] A. M. A. Haidar, A. Mohamed, and A. Hussain, "Vulnerability Assessment of Power System Using Various Vulnerability Indices", *4th Student Conference on Research and Development*, 2006.
- [8] A. M. Haidar, A. Mohamed, and A. Hussain, "Vulnerability control of large scale interconnected power system using neuro-fuzzy load shedding approach", *Expert Systems with Applications*, Vol. 37, No. 4, pp. 3171–3176, 2010.
- [9] R. Hooshmand and M. Moazzami, "Optimal design of adaptive under frequency load shedding using artificial neural networks in isolated power system", *International Journal of Electrical Power & Energy Systems*, Vol. 42, No. 1, pp. 220–228, 2012.
- [10] M. M. Jalali and A. Kazemi, "Demand side management in a smart grid with multiple electricity suppliers", *Energy*, Vol. 81, pp. 766–776, 2015.
- [11] J. Laghari, H. Mokhlis, A. Bakar, and H. Mohamad, "Application of computational intelligence techniques for load shedding in power systems: A review", *Energy Conversion and Management*, Vol. 75, pp. 130–140, 2013.
- [12] T. N. Le, H. A. Quyen, and N. A. Nguyen, "Application of fuzzy-analytic hierarchy process algorithm and fuzzy load profile for load shedding in power systems", *International Journal of Electrical Power & Energy Systems*, Vol. 77, pp. 178–184, 2016.
- [13] A. S. Malik and M. Bouzguenda, "Effects of smart grid technologies on capacity and energy savings – A case study of Oman", *Energy*, Vol. 54, pp. 365–371, 2013.
- [14] M. Moazzami and A. Khodabakhshian, "A new optimal adaptive under frequency load shedding Using Artificial Neural Networks", *18th Iranian Conference on Electrical Engineering*, 2010.
- [15] N. Sapari, H. Mokhlis, J. A. Laghari, A. Bakar, and M. Dahalan, "Application of load shedding schemes for distribution network connected with distributed generation: A review", *Renewable and Sustainable Energy Reviews*, Vol. 82, pp. 858–867, 2018.
- [16] E. Zakaria, A. A. Awamry, A. Taman, and A. Zekry, "A novel vertical handover algorithm based on Adaptive Neuro-Fuzzy Inference System (ANFIS)", *International Journal of Engineering & Technology*, Vol. 7, No. 1, p. 74, 2018.