

Implementation of RFID in Bus Boarding System for Visually Impaired People

G.Revathi¹, T.Nandhini², S.Priyadarsini³ and K.Preethi⁴
^{1,2,3}UG Scholar, ⁴Assistant Professor

Department of Electronics & Communication Engineering,
AVS Engineering College, Salem, Tamil Nadu, India
Email: revathitech2@gmail.com, nandytech16@gmail.com
priyas2514@gmail.com, vp.nikith@gmail.com

(Received 3 April 2017; Revised 25 April 2017; Accepted 15 May 2017; Available online 23 May 2017)

Abstract - As an engineer we have a social responsibility towards the improvement in our society. So for that reason we design a mechanism to help the blind people for travelling without any assistance by using our devices. Journey in a bus is a safe and comfort factor but navigation in outdoor environment is highly difficult for those who have congenital blindness or blind people. Several solutions have been proposed like walking stick or white cane, guide dogs and GPS guidelines to deal with this difficulty. Although some of them have shown to be useful in real scenarios, they involve an important deployment effort or use artifacts that are not natural for blind users.

Therefore, this paper aims to develop a bus detection prototype using Radio Frequency Identification (RFID) for blind. RFID has the potential to be a useful aid with further standardization of RFID tags and improvement of current RFID readers. Here the system contains the RFID communication technology to communicate blind person with the bus. The two major parts are there. 1. RFID Tag (from bus). 2. RFID Reader (from blind people). Using the two things the blind person freely uses the transport system without any assistance.

Keywords: Blind people, Navigation system, Ultrasonic sensor, PIC16F877A, RFID, Voice recognition module

I. INTRODUCTION

Radio Frequency Identification (RFID) is the emerging technology in recent year and it has lot of advantage in this field.

In most of the application, the RFID technology is used to implement the design and modules for different control system. The purpose of this paper will be to develop a design and purpose a plan to implement RFID technology that will help the blind people navigation.

For blind people, outdoor pedestrian mobility is very complicated and dangerous to the blind. The visually impaired is commonly rely on a white cane or walking stick and a guide dog to assist them without harm to reach an accurate path. However, the guidance system is useful to help the blind, but only if the majority of the path is already know to the blind people.

Buses play an important role during traveling time. Majority of blind and visually impaired people travel in the public transport and it is only feasible transport option to seek social connectivity.

The people who lives in that particular environment is difficult to sense what happen around us, these activities will be reduced in several fields. Normally, the blind people need in assistance, while travelling in a bus. But in our proposed system we using RFID technology to help the blind people traveling in a bus and feel more comfortable and enjoying like an ordinary people without any assistance during transportation.

For this purpose, we introduce a bus detection system using RFID technology is more suitable for the mobility of blind people. In our proposed system is consists of the two systems, one on the bus act as a transmitter (RFID TAG) and other in the blind people who act as a receiver (RFID READER).

The RFID TAG can send the details about the bus route, bus name, timing, distance and also existing bus information to the blind people by using RFID READER. RFID reader receives the detail about the bus information and announce through voice module to the blind people. A complete system is constructed and tested to valid a proposed system. In our proposed system results show that system performance is effectively safe and reasonable cost.

II. BLOCK DIAGRAM REPRESENTATION

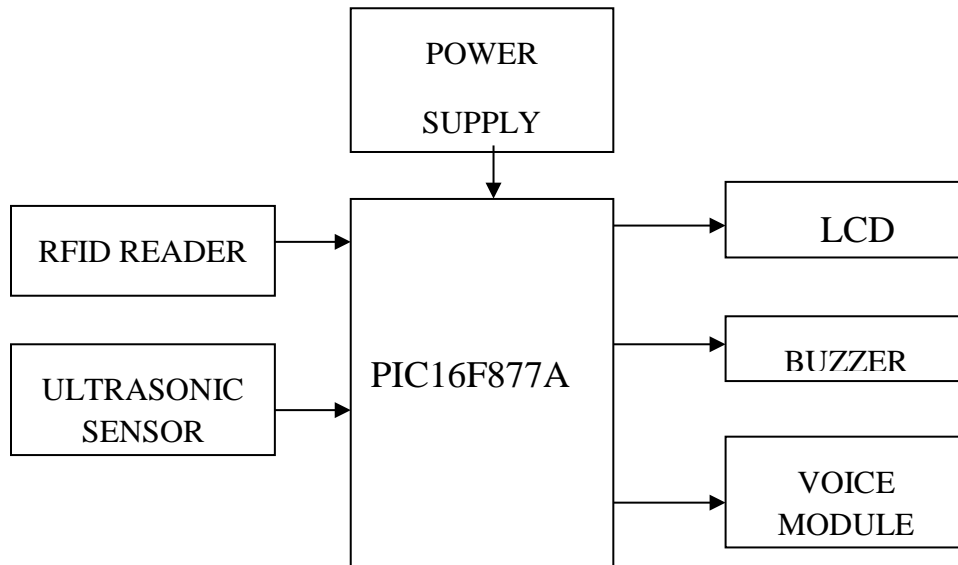

Fig.1 Block diagram for bus boarding system using RFID

III. DESIGN METHODOLOGY

The execution of the product details is given by,

- Destination voice to the blind
- Tag identification to reach the destination
- Ultrasonic sensor detection
- Buzzer ring and voice module

A. Destination voice to the blind

Microcontrollers offer different kinds of memories such as EEPROM, EPROM, FLASH etc. In these, FLASH is the most recently emerging technology that is used in PIC 16F877A microcontroller, so that data is retained even when the power is switched off. Easy Programming and Erasing are other features of PIC 16F877A. PIC 16F877A CMOS Flash unit contains 8 bit microcontroller and the 200 instruction executed in nano seconds per cycle. PIC 16F877A has high performance RISC CPU and its operating voltage range is 2 to 5.5V with the temperature range -40 to +125. PIC 16F877A has highly flexible low cost microcontroller design tool and low power consumption. So, in our proposed system using PIC 16F877A microcontroller can hear all the sounds in the maximum frequency range of 20MHZ to effectively sense the word by the blind people.

B. Tag identification to reach the destination

Radio-frequency identification (RFID) uses electromagnetic field to automatically identify and track tags attached to objects. The tags contain electronically stored information. Passive tags collect energy from a nearby RFID reader's

interrogating radio waves. Active tags have a local power source such as a battery and may operate at hundreds of meters from the RFID reader. Unlike a barcode, the tag need not be within the line of sight of the reader, so it may be embedded in the tracked object. RFID is one method for Automatic identification and data capture (AIDC). RFID systems consist of three components are RFID tag, reader, and an antenna.

1. RFID TAG

RFID tags can be used either passive or active tag. An active tag has an on-board battery and periodically transmits its ID signal and it has a small battery on board to activate in the presence of the RFID reader. A passive tag is cheaper and smaller because it has no battery and the tag uses the radio energy transmitted by the reader. Field programmable tags may be writes-once, read-multiple; "blank" tags may be written with an electronic product code by the user.

RFID tags contain at least two parts: an integrated circuit for storing and processing information, modulating and demodulating a radio frequency (RF) signal, collecting DC power from the incident reader signal and the tag information is stored in a non-volatile memory. The RFID tag includes either fixed or programmable logic for processing the transmission and sensor data, respectively.

An RFID reader transmits an encoded radio signal to interrogate the tag. The RFID tag receives the message and then responds with its identification and other information. This may be only a unique tag serial number.

2.RFID Reader

The radio frequency is used to decode the data in the RFID tag and is produced by the RFID reader. When a radiofrequency wave interacts with an RFID tag, the pins or the bar code energizes and produces its own magnetic field which has a unique interference pattern and the information read by the RFID reader and it would obtain the unique number designated to the corresponding RFID tag. Thus the RFID reader obtains the address of the desired RFID tag to identified the tag and get the information [1]. The below diagram represents the RFID Communication,

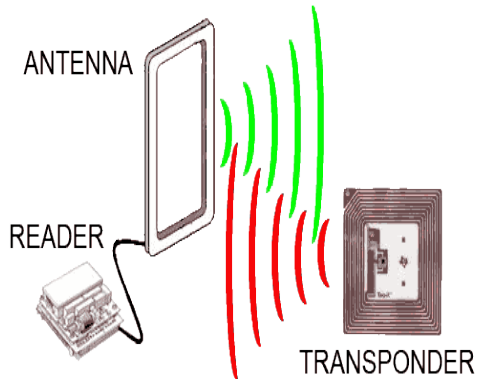

Fig.2 RFID Communication

C. Ultrasonic Sensor Detection

Ultrasonic sensors emit short, high-frequency sound pulses at regular intervals. These propagate in the air at the velocity of sound. If they strike an object, then they are reflected back as echo signals to the sensor. Ultrasonic waves are sounds which cannot be heard by humans in the normal condition, with frequencies of above 20 kHz. In order to detect the presence of an object, ultrasonic waves are reflected on objects. It is used to detect the obstacles in front of the blind to navigate [2].The given below diagram represents the HC-SR04 sensor.



Fig.4 HC-SR04 Sensor

D.Buzzer Ring and Voice Module

A buzzer is an audio signaling device which may be mechanical, electromechanical, or piezoelectric. Typical uses of buzzers and beepers include alarm devices, timers, and confirmation of user input. A piezoelectric buzzer can be driven by an oscillating electronic circuit or other audio signal source. A click, beep or ring can indicate that a button has been pressed. The given below diagram represents the buzzer,

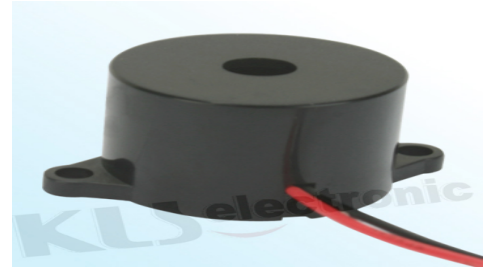

Fig.4 Buzzer

IV. WORKING PRINCIPLES

Our proposed model consists of two parts. The first one is RFID tag. This tag is placed into the bus in which the information are feed into the tag and each bus having own RFID tag. Through the electromagnetic field, the information about the bus is send by RFID tag to the RFID reader. Whenever it's enter the RFID receiver are it will get the energy from the transmitter and then send the details to it. The second one is receiver system. Blind person had this receiver unit. It is used to read the information's from the bus then convert into voice then play the voice through the voice board module. Also the obstacle sensor is used to sense the objects in between the path. If there is any obstacle in the path and it will sound through buzzer then the blind people safe and clearly identify the path to reach the destination. The given below diagram represents the working principle connection of the blind unit. The below diagram represents the steps involved in RFID technology to navigate the blind people without any assistance.

1. The RFID Tag and RFID Reader act as transmitter and receiver respectively.
2. The antenna sending high frequency of electromagnetic waves.
3. The RFID Reader converted the waves into speech through voice module.
4. The obstacle sensor is used to sense the object.
5. Buzzer is to indicate the blind people to reach the destination safe and clearly without any assistance

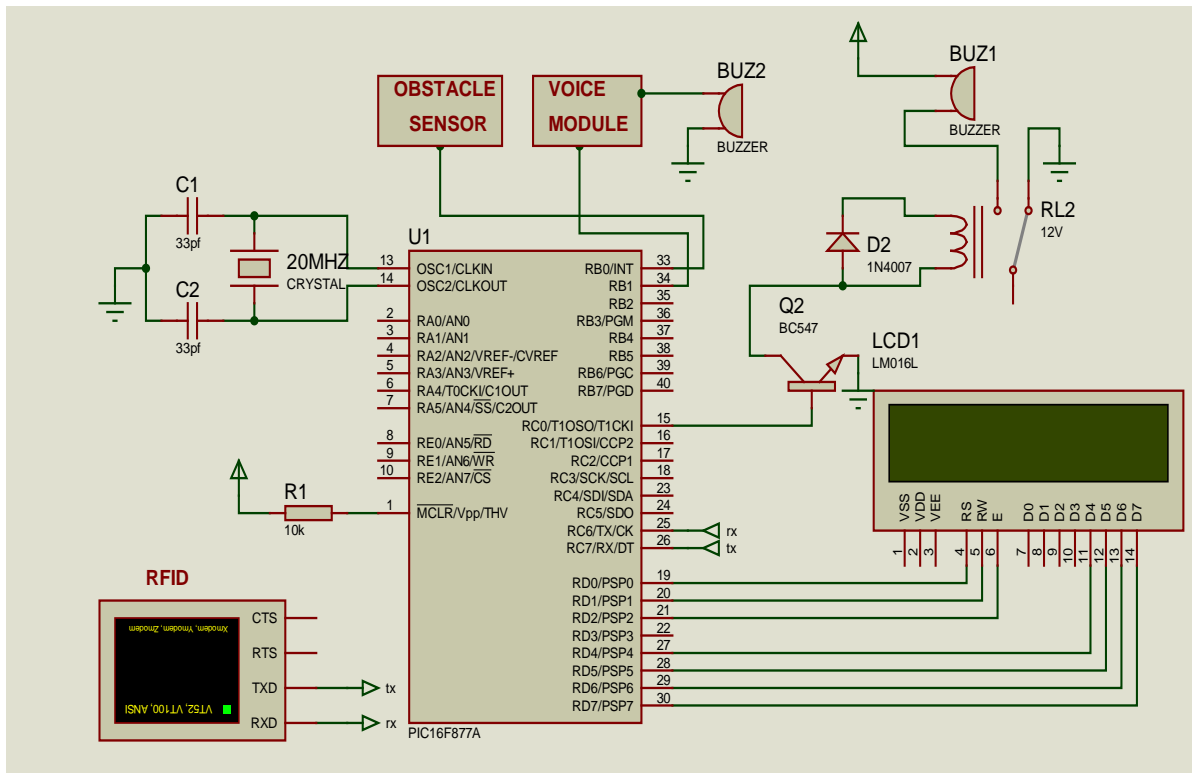

Fig.5 working principle of blind unit

V. RESULTS AND DISCUSSION

To navigate the blind people without any assistance has been successfully implemented by using RFID technology. In our proposed system the results has three units are

1. Hardware-Blind unit
2. Hardware-RFID Tag unit
3. Hardware-RFID Reader unit

1. Hardware-Blind unit

The Figure 6 shows the hardware blind unit. The hardware unit consist of the RFID Reader , RFID Tag, ultrasonic sensor, buzzer, voice module are used to navigate the blind people without any assistance.



Fig.6 Hardware-Blind uni

2. Hardware-RFID Tag unit

The Figure 7 shows the hardware-RFID Tag unit. RFID Tag is used to store the information of the bus by the program.

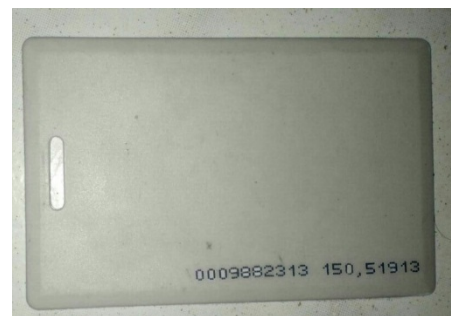

Fig.7 Hardware-RFID Tag

3. Hardware-RFID Reader unit

The Figure 8 shows the hardware-RFID Reader unit. The RFID Reader receives the bus details from RFID Tag and converted through speech by using voice modules then he/she starts to move.



Fig.8 Hardware-RFID Reader Tag

VI. CONCLUSION

The visually impaired people need some aid to interact with their environment with more security. For security purpose we implement the RFID Technology to navigate the blind people without any assistance. The interactive blind aid system for the visually impaired is used to travel like a normal people in the buses comfortably so, we developed in this system. In our proposed system the ultra-high frequency radio waves is used to show in the implemented system which will use the RFID tag and reader setup along with

customized program that will help the blind people identifying the exact bus. Result of the test is indicated to the system that helps to reach the desired bus successfully by using the interactive communication modules. Thus, the RFID technology is used to help the blind people.

REFERENCES

- [1] Aras M S M, Jamri M S, Kassim A M, Rashid M Z A, Yaacob M R. 'Design and development of obstacle detection and warning device for above abdomen level, 'Proceedings of 12th International Conference on Control, Automation and Systems (ICCAS), 2012, pp. 410–13.
- [2] Anwar N S N, Jamaluddin H, Kassim A M, Sani Z M, Yaacob M R. 'Design and Development of MY 2nd EYE for Visually Impaired Person', Proceedings of IEEE Symposium on Industrial Electronics and Applications, (ISIEA), 2011, pp.700–703.
- [3] Bin Ding Sch. of Manage. Univ. of Sci. & Technol. Of China, "The Research on Blind Navigation System Based on RFID", ISBN: 978-1-4244-1311-9, Page(s) : 2058 –2061, 21-25 Sept. 2007.
- [4] Dhananjeyan .S, Dr. K. Mohana Sundaram, A. Kalaiyarasi ,Dr. P. G. Kuppusamy“ Design and Development of Blind Navigation System using GSM and RFID Technology” Indian Journal of Science and Technology, Vol 9(2), DOI: 10.17485/ijst/2016/v9i2/85809, January 2016, www.ijst.com.
- [5] SaritaPais and Judith Symonds, "Data storage on a RFID tag for a distributed system", International Journal of Ubicomp(IJU),vol.2,No.2, April 2011.
- [6] Singh J, Bhardwaj P. 'Design and Development of Secure Navigation System for Visually Impaired People' International Journal of Computer Science Technology, 2013, 5(4), pp. 159–64.
- [7] V. T. Pham, Q. Qiu, A. A. P. Wai and J. Biswas, "Application of ultrasonic sensors in a smart environment", Pervasive and Mobile Computing, Vol. 3, pp. 180--207, March 2007