

Performance Analysis of Intelligent Controllers for Automatic Voltage Regulator (AVR)

Ajit Kumar Mittal¹ and Pankaj Rai²

¹M.Tech Student, ²Associate Professor

Department of Electrical Engineering, B.I.T Sindri, Dhanbad, India

Email: ¹Kumarmittal0810@gmail.com, ²pr_bit2001@yahoo.com

(Received 6 July 2016; Revised 23 July 2016; Accepted 14 August 2016; Available online 20 August 2016)

Abstract - This paper present performance analysis of different type of intelligent controllers for Automatic Voltage Regulator. The main purpose of the AVR is to control the terminal voltage of synchronous generator at a specified level. The modelled system composed of the amplifier, exciter, generator and sensor. In this paper, simulation and comparative analysis of the Automatic Voltage Regulator has been carried out by using Fuzzy Logic controller, Fuzzy-IMC controller and Self tuning Fuzzy-PID controller and the results are presented. The proposed controller gives a better response in terms of settling time and overshoot.

Keywords: Automatic Voltage Regulator, Fuzzy Logic Controller, Fuzzy-IMC Controller, Self-Tuning Fuzzy- PID Controller.

I. INTRODUCTION

The main objective of the control strategy in power system is to generate and deliver power in an interconnected system as economically and reliably as possible while maintaining the voltage in the steady state within permissible limit [2]. The Automatic Voltage Regulator (AVR) is used in industrial application to obtain the stability and good regulation of different electrical apparatus. The AVR system controls the terminal voltage by adjusting the exciter voltage of the generator. The role of an AVR is to keep the generator terminal voltage level constant under normal operating terms at different load levels [1]. The fundamental Components of an AVR system compose of four main components namely amplifier, exciter, generator and sensor [1, 2].

In this paper, intelligent controllers have been proposed. Intelligent controllers utilize a new approaches to the controller design in which knowledge of mathematical model of a process generally is not required [8]. Examples of intelligent controller are fuzzy logic controller, self-tuning fuzzy-PID controller etc [5, 3, 10]. Many industrial processes are nonlinear and thus complicate to describe mathematically. Fuzzy logic controller has been used for both linear and non-linear system [10]. Intelligent controllers such as fuzzy logic controller, fuzzy-IMC and self-tuning fuzzy-PID controller have been proposed. By the using of intelligent controller overshoot becomes zero. In fuzzy logic controller settling time is high. There is a need to minimize the settling time. By using of self-tuning fuzzy-PID controller, it has been achieved.

II. AUTOMATIC VOLTAGE REGULATOR SYSTEM

An AVR system is used in synchronous generator to hold the magnitude of terminal voltage at a specified level. AVR composes of four main components which are amplifier, exciter, generator and sensor. The simple schematic diagram of an AVR as shown in figure 1.

An increase in the reactive power load of the generator is accompanied by a drop in the terminal voltage magnitude. The voltage magnitude is sensed through a potential transformer.

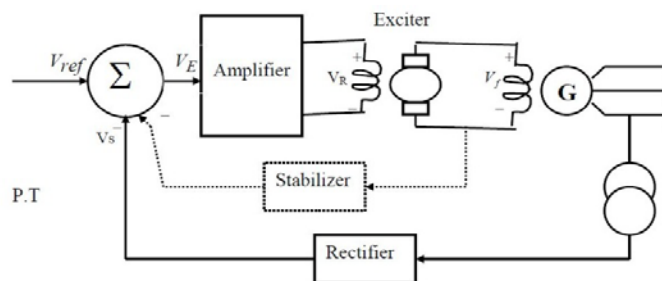

Fig.1 Simple Schematic Diagram of an AVR

This voltage is rectified and compared to a dc set point signal. The amplified error signal controls the exciter field and increases the exciter terminal voltage. Thus, the generator field current is increased, which results in an

increase in the generated emf. The reactive power generation is increased to a new equilibrium, raising the terminal voltage to the desired value.

A. Mathematical Modeling

An AVR system is used in synchronous generator to hold the magnitude of the terminal voltage at a specified level. It composes of four main components which are named as amplifier, exciter, generator and sensor. Mathematical modeling of these components needs to consider their transfer functions linearized. However, nonlinear conditions are not considered in this study.

1) Amplifier Model

The excitation system amplifier may be a magnetic amplifier, rotating amplifier or modern electronic amplifier. The amplifier transfer function is given by

$$\frac{V_R(s)}{V_E(s)} = \frac{K_A}{1 + s\tau_A} \tag{1}$$

2) Exciter Model

The exciter of the synchronous generator is the main component in the AVR loop. The main function of exciter is to provide dc current to the field of synchronous generator. The exciter transfer function is given by

$$\frac{V_F(s)}{V_R(s)} = \frac{K_E}{1 + s\tau_E} \tag{2}$$

3) Generator Model

The synchronous machine generated emf is a function of the machine magnetization curve and its terminal voltage is dependent on the generator load. The generator transfer function is given by

$$\frac{V_t(s)}{V_F(s)} = \frac{K_G}{1 + s\tau_G} \tag{3}$$

4) Sensor Model

The voltage is sensed through a potential transformer and, in one form, it is rectified through a bridge rectifier. The sensor is modeled by a simple first order transfer function, given by

$$\frac{V_s(s)}{V_t(s)} = \frac{K_R}{1 + s\tau_R} \tag{4}$$

The block diagram of an AVR is shown in figure 2.

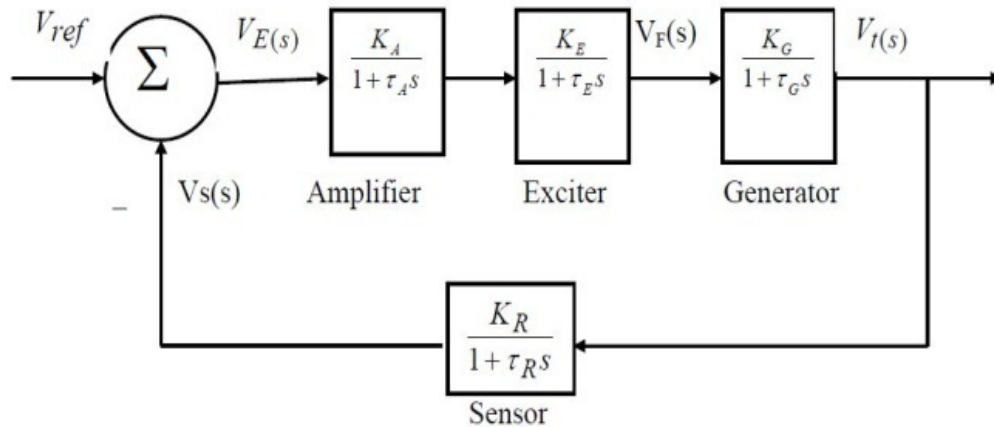

Fig. 2 Block diagram of Simple AVR

TABLE 1 TRANSFER FUNCTION OF AVR COMPONENT

Model	Transfer Function	Parameter Limits	Nominal Values
Amplifier	$\frac{V_R(s)}{V_E(s)} = \frac{K_A}{1 + s\tau_A}$	$10 \leq K_A \leq 400$ $0.02 \leq \tau_A \leq 0.1$	$K_A = 10$ $\tau_A = 0.05$
Exciter	$\frac{V_F(s)}{V_R(s)} = \frac{K_E}{1 + s\tau_E}$	$1 \leq K_E \leq 400$ $0.5 \leq \tau_E \leq 1$	$K_E = 10$ $\tau_E = 0.5$
Generator	$\frac{V_t(s)}{V_F(s)} = \frac{K_G}{1 + s\tau_G}$	$0.7 \leq K_G \leq 1$ $1 \leq \tau_G \leq 2$	$K_G = 0.8$ $\tau_G = 1.5$
Sensor	$\frac{V_s(s)}{V_t(s)} = \frac{K_R}{1 + s\tau_R}$	$0.001 \leq \tau_R \leq 0.06$	$\tau_R = 0.05$

III. DIFFERENT INTELLIGENT CONTROLLERS

A. Fuzzy Logic Controller (FLC)

In last three decades, fuzzy control has gained much popularity owing to its knowledge base algorithm, better non-linearity handling features and independence of plant modeling. The FLC owes its popularity to linguistic control. In fuzzy logic controller mathematical modeling is not required. Hence, fuzzy logic works on the basis of the

human thought process in its control algorithm. A fuzzy logic controller makes good performance in terms of stability, precision reliability and rapidity achievable.

The fuzzy controller has been designed with two input variables, error and rate of change error and one output variable. Block diagram of simple fuzzy logic controller as shown in figure 3.

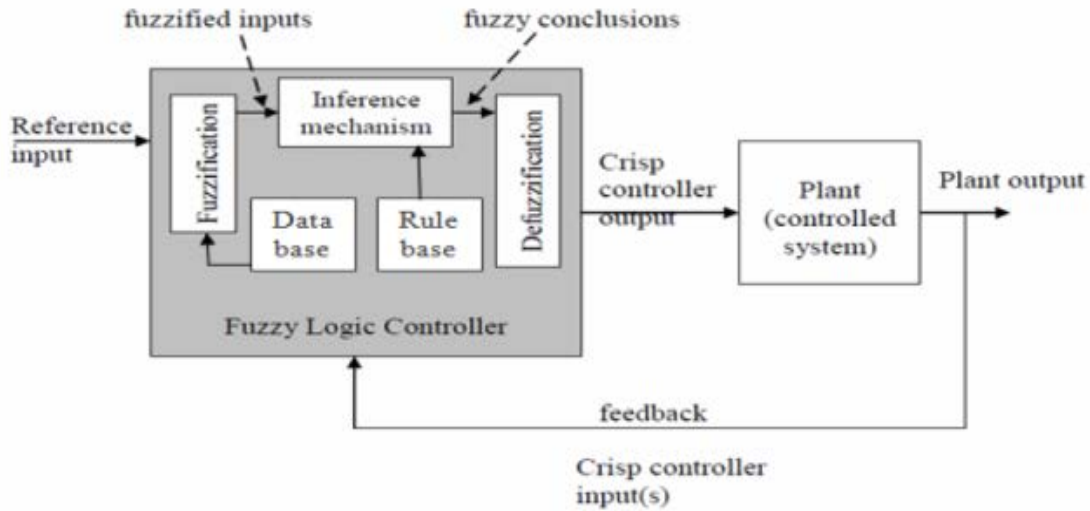

Fig.3 Block Diagram of Fuzzy Logic Control

Figure 4, 5 and 6 shows membership functions of different variables implemented in FIS editor in MATLAB toolbox, the rule base framed for automatic voltage regulator are

tabulated in Table 2 and Figure 7 shows surface view of all variables in 3 dimensions.

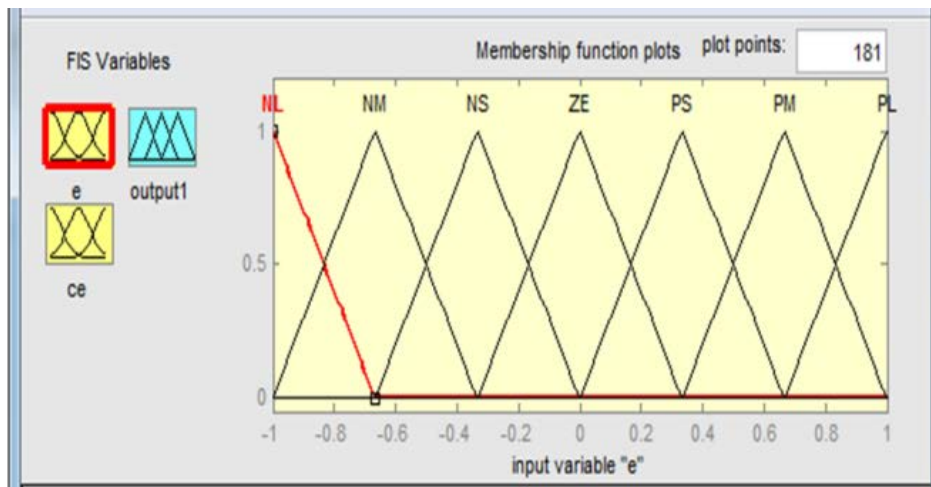

Fig.4 Membership Function for Input Variable 1 (e)

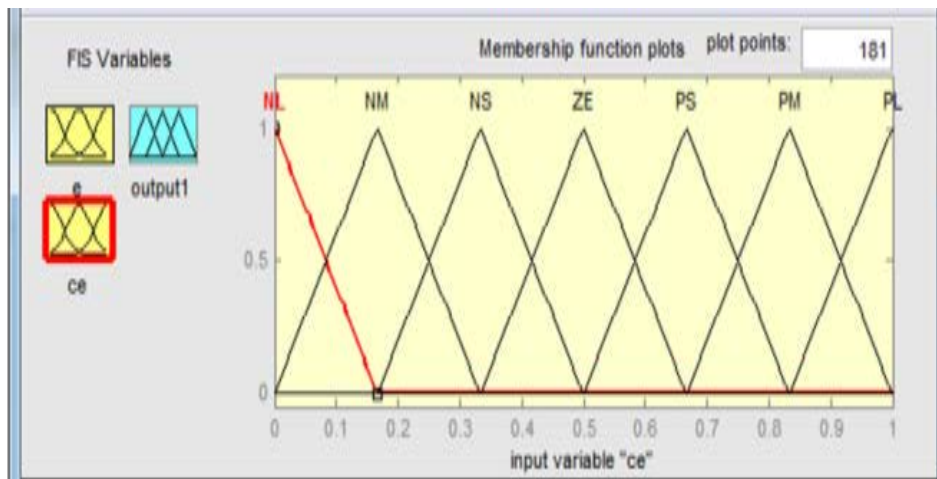

Fig.5 Membership Function for Input Variable 2 (ce)

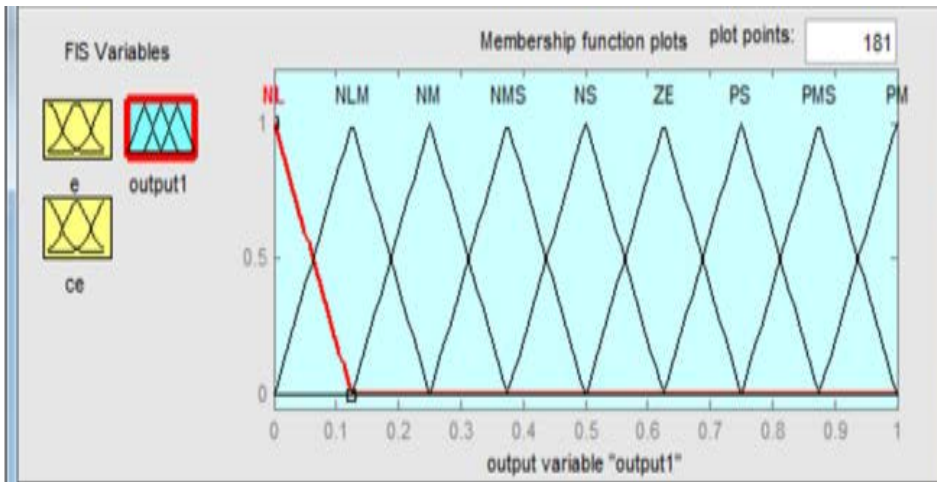

Fig.6 Membership Function for Output Variable

TABLE 2 RULE BASE FOR 2 INPUTS AND 1 OUTPUT

e \ ce	NL	NM	NS	ZE	PS	PM	PL
NL	NL	NL	NLM	NM	NMS	NS	ZE
NM	NL	NLM	NM	NMS	NS	ZE	PS
NS	NLM	NM	NMS	NS	ZE	PS	PMS
ZE	NM	NMS	NS	ZE	PS	PMS	PM
PS	NMS	NS	ZE	PS	PMS	PM	PM
PM	NS	ZE	PS	PMS	PM	PM	PM
PL	ZE	PS	PMS	PM	PM	PM	PM

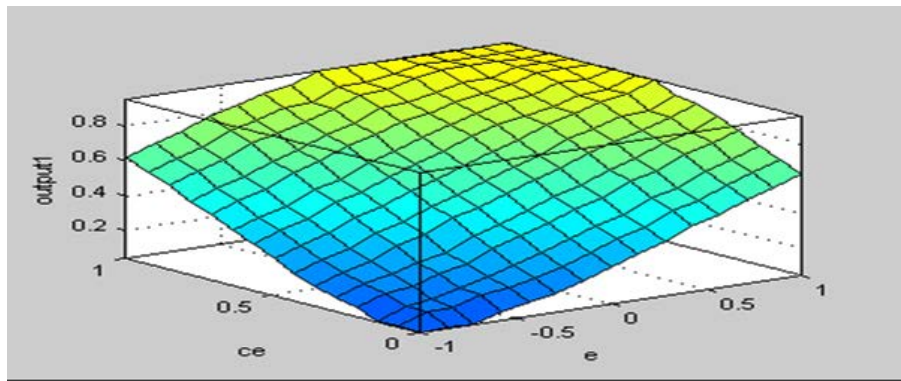

Fig.7 Surface View for 2 Inputs and 1 Output Variable

B. Self-Tuning Fuzzy-PID Controller

Self-tuning fuzzy PID controller means that the three parameters K_p , K_i and K_d of PID controller are tuned by using fuzzy tuner . The coefficients of the conventional PID

controller are not often properly tuned for the nonlinear plant with unpredictable parameter variations. Hence, it is necessary to automatically tune the PID parameters. The structure of the self tuning fuzzy-PID controller is shown in figure 8.

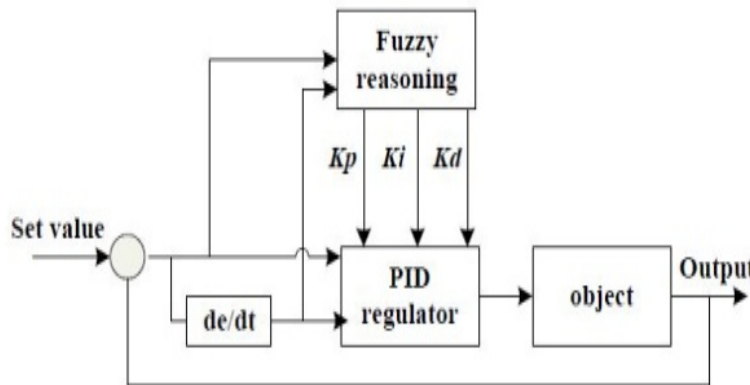

Fig.8 Structure of Self Tuning Fuzzy-PID Controller

Where $e(t)$ is the error between desired position set point and the output, $de(t)$ is the derivation of error. The PID parameters are tuned by using fuzzy inference, which

provide a nonlinear mapping from the error and derivation of error to PID parameters. Fuzzy inference block of the self-tuning fuzzy-PID controller is shown in figure 9.

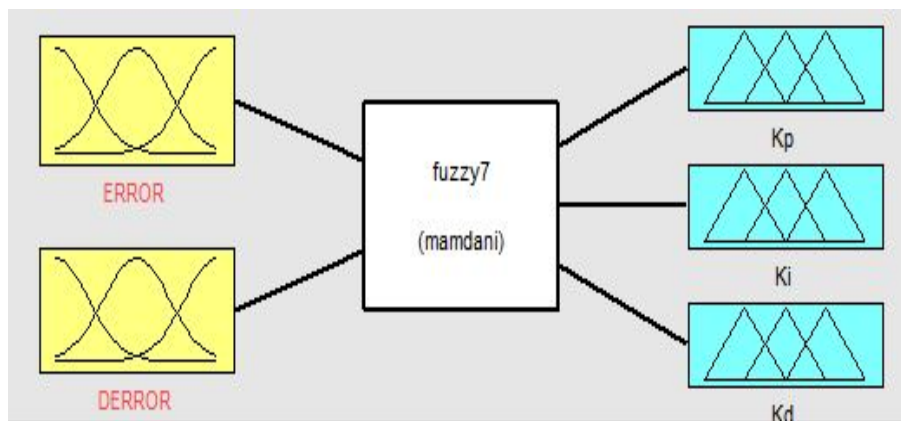

Fig.9 Fuzzy Inference Block

Figure 10, 11 and 12 shows membership functions of different variables implemented in FIS editor in MATLAB toolbox, the rule base framed for automatic voltage

regulator are tabulated in Table 3 and Figure 13 shows surface view of all variables in 3 dimensions.

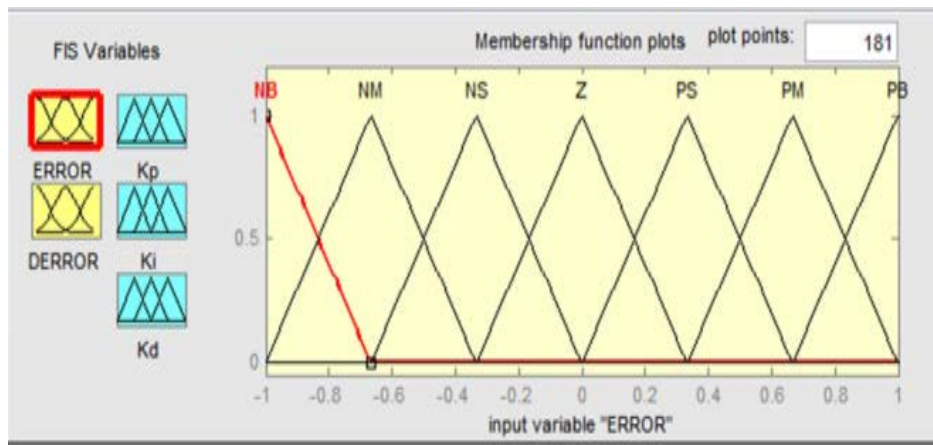

Fig.10 Membership Function for Input Variable Error

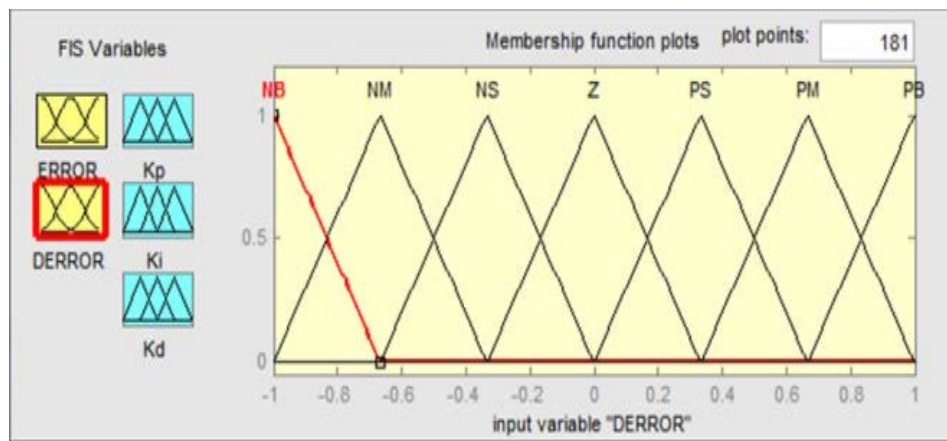

Fig.11 Membership Function for Input Variable Derror

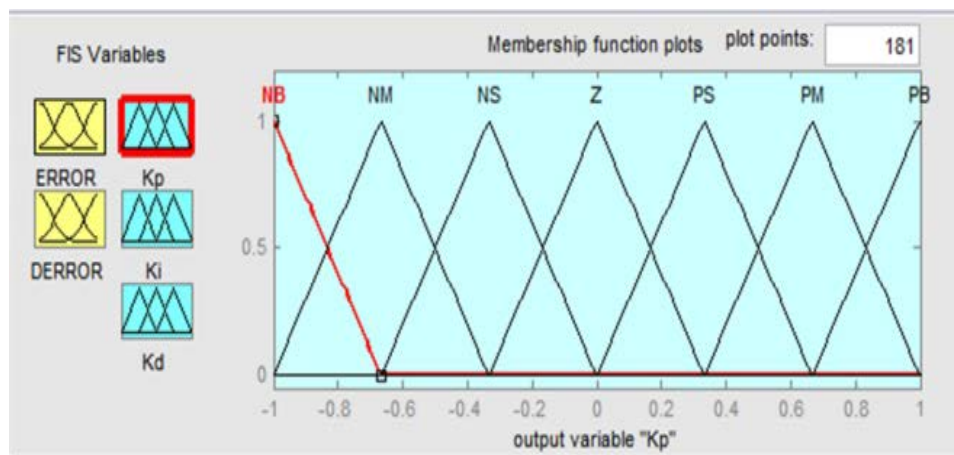

Fig.12 Membership Function for Output Variable (Kp, Ki and Kd)

TABLE 3 RULE BASE FOR KP, KI AND KD

e de	NB	NM	NS	Z	PS	PM	PB
NB	NB	NB	NB	NB	NM	NS	Z
NM	NB	NB	NB	NM	NS	Z	PS
NS	NB	NB	NM	NS	Z	PS	PM
Z	NB	NM	NS	Z	PS	PM	PB
PS	NM	NS	Z	PS	PM	PB	PB
PM	NS	Z	PS	PM	PB	PB	PB
PB	Z	PS	PM	PB	PB	PB	PB

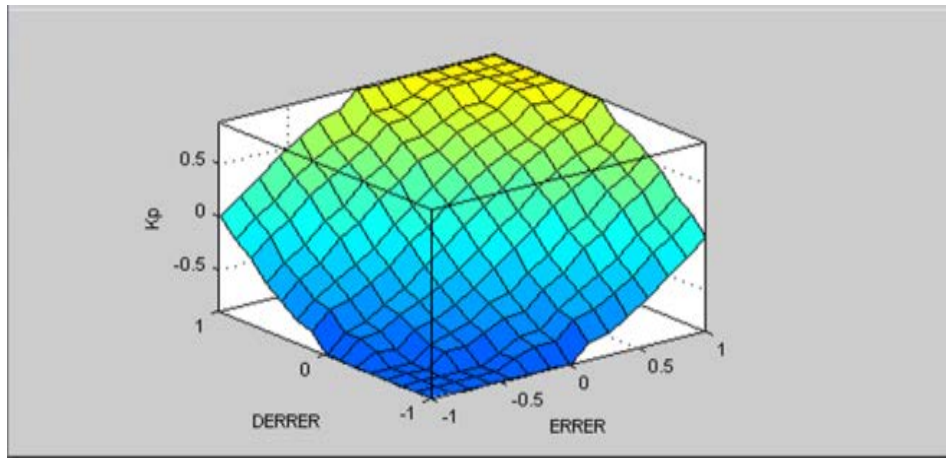

Fig.13 Surface View for 2 Inputs and 3 Outputs

IV. SIMULATION

The simulations for different intelligent control mechanism discussed above have been carried out in Simulink in MATLAB environment and simulation results have been

obtained. Figure 14, 15, 16 and 17 shows the simulink model of Fuzzy logic controller, Fuzzy-IMC controller, self-tuning Fuzzy-PID controller and subsystem block of Fuzzy-PID controller.

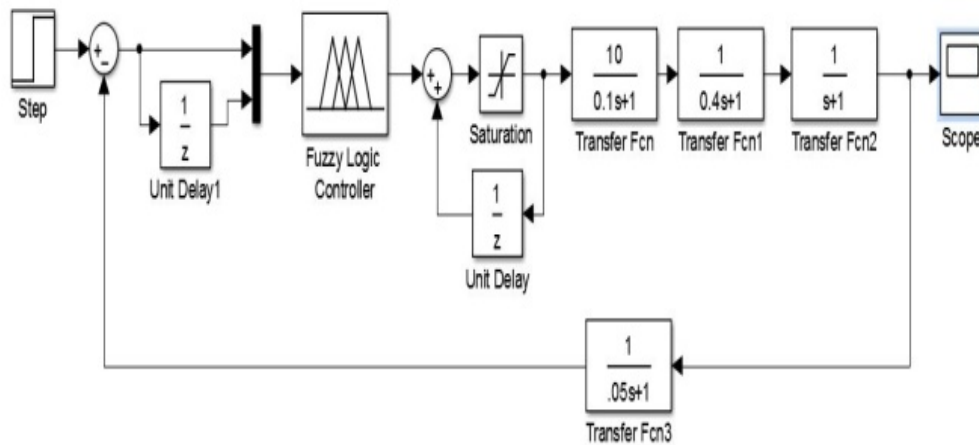

Fig.14 Simulink of AVR with Fuzzy Logic Controller

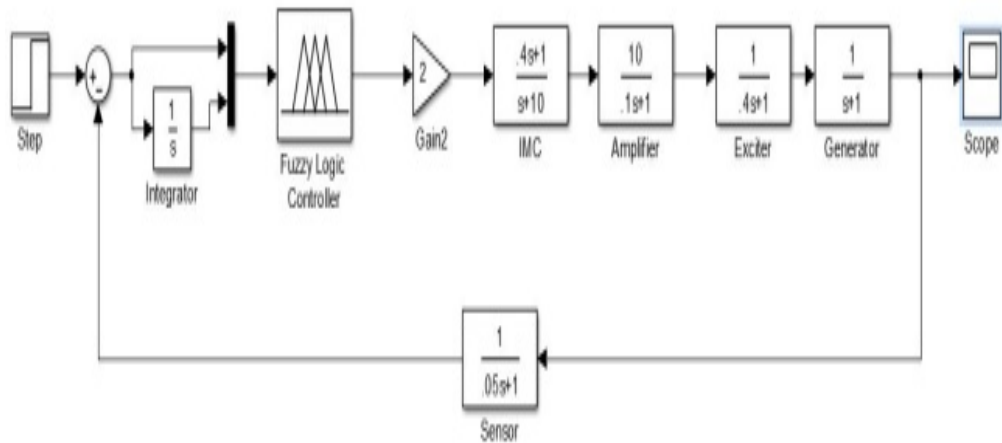

Fig.15 Simulink of AVR with Fuzzy-IMC Controller

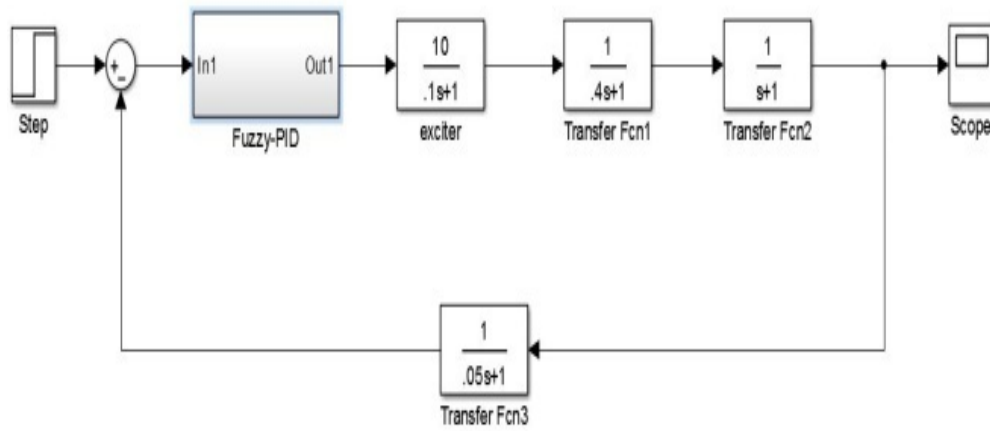

Fig.16 Simulink of AVR with Self Tuning Fuzzy-PID Controller

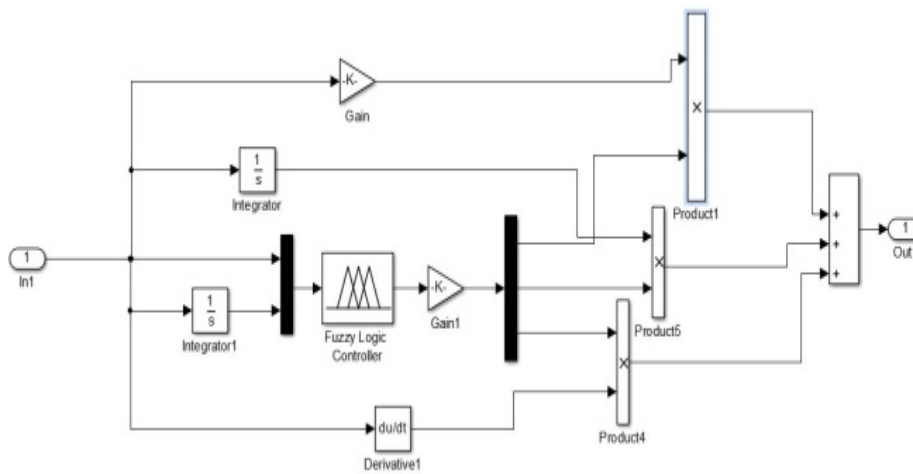

Fig.17 Subsystem Block of Fuzzy-PID Controller

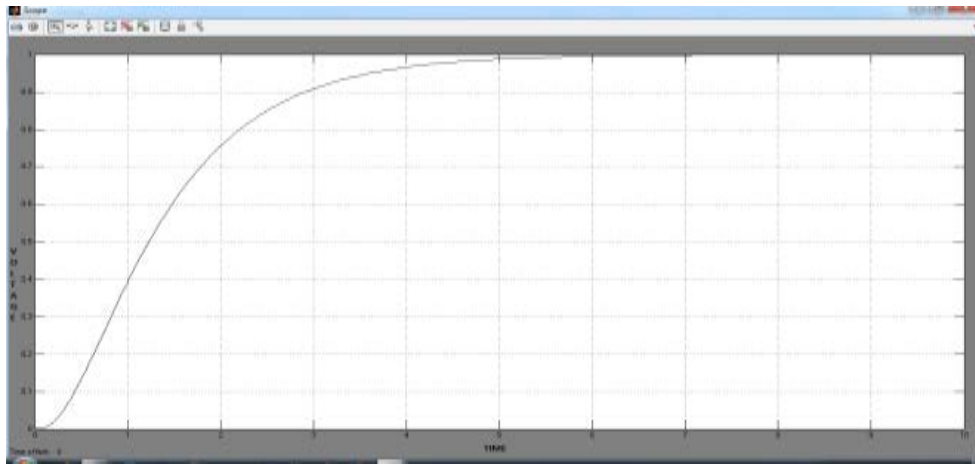

Fig.18 Output Response of AVR for Fuzzy Logic Controller

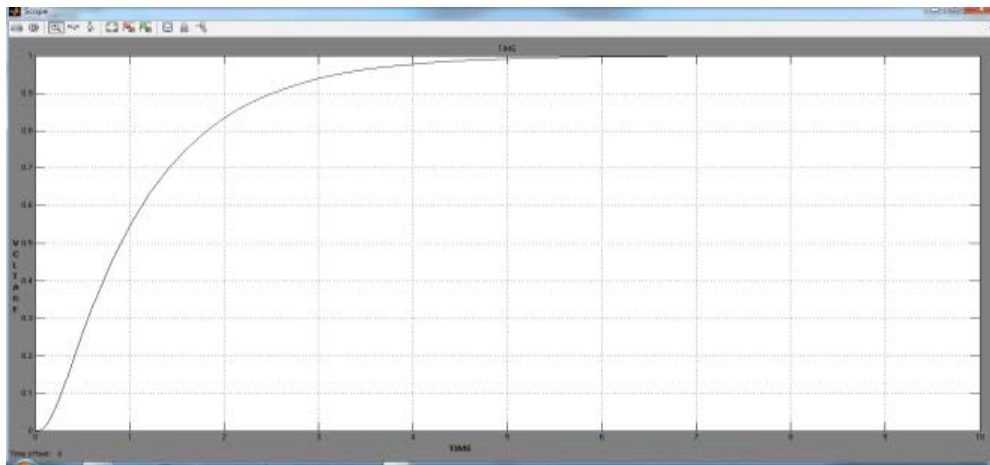

Fig.19 Output Response of AVR for Fuzzy-IMC Controller

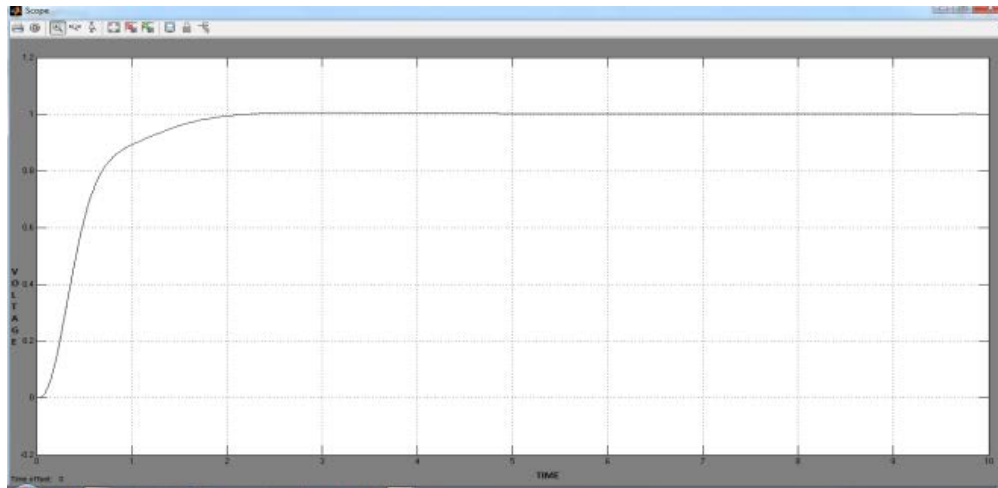

Fig.20 Output response of AVR for Fuzzy-PID controller

Figure 18, 19 and 20 shows the unit step response of AVR for Fuzzy logic controller, Fuzzy-IMC controller and Self tuning Fuzzy-PID controller.

V. RESULT AND DISCUSSION

Performance analyses of different intelligent controllers as shown in table 4.

TABLE 4 PERFORMANCE ANALYSIS OF DIFFERENT INTELLIGENT CONTROLLERS

Parameter Controller	Rise time (in sec.)	Settling time (in sec.)	%overshoot
FLC	2.48	4.52	00
Fuzzy-IMC	2.51	4.11	00
Fuzzy-PID	0.87	1.74	00

From table 4, it has been observed that overshoot can be reduced to 0% in all the three cases. But the settling time of Fuzzy and Fuzzy-IMC is large. It has been reduced by using self-tuning Fuzzy-PID controller. So, self-tuning Fuzzy-PID controller gives the better performance.

VI. CONCLUSION

In this paper, comparative study of performance analyses of different type of intelligent controllers has been studied. The aim of the proposed controller is to regulate the terminal voltage of synchronous generator to a desired voltage in the shortest possible time with minimum overshoot. It has been observed that overshoot can be reduced to 0 % in all the three cases. After comparing results for different intelligent controllers, it has been observed that settling time can be reduced by using self-tuning Fuzzy-PID controller. So, self-tuning Fuzzy-PID controller gives the better performance in terms of settling time and overshoot.

REFERENCES

- [1] Abhijit Chakrabarti, Sunita Halder, "Power System Analysis Operation and Control", PHI Publication, 2012.
- [2] H.Saadat, "Power System Analysis", New York, McGraw-Hill, 1999.
- [3] L.J. Nagrath., M. Gopal, "control system engineering", 5th ed. New age International Publishers, 2010.
- [4] J.Faiz, Gh.Shahgholian, M.Arezoomand, "Analysis and Simulation of the AVR System and Parameters Variation Effects", Powereng 2007, April 12-14, 2007, Setubal, Portugal.
- [5] K.Y.Lee, "Fuzzy logic Applications in power system", IEES-PES winter meeting in Singapore, vol. 4 january, 2000.
- [6] M. Baha Bayram, H. Ibrahim Bulbul, Celal Can, and Ramazan Bayindir "MATLAB/GUI Based Basic Design Principles of PID Controller in AVR", 4th International Conference on Power Engineering, Energy and Electrical Drives, 13-17 May 2013, Istanbul, Turkey, 1017-1022.
- [7] McArdle, Morrow, D. J. Calvert, P. A. J and Cadel, O. "Hybrid PI and PD type Fuzzy logic controller for Automatic Voltage Regulation of the small alternator", Proceedings of Power Engineering Society Summer meet, vol. 3, pp. 1340-1345, 2001.
- [8] N.Madinehi, K.Shaloudegi, M. Abedi, H.A.Abyaneh, "Optimum Design of PID Controller in AVR System Using Intelligent Methods", IEEE Trondheim Power Tech, 2011.
- [9] Prabha Kundur, "Power System Stability and Control" McGraw-Hill, 1994.
- [10] S.N.Sivanandam, S.N.Deepa, "Principles of Soft Computing" Wiley Publication, 2014.
- [11] T.L.Seng, M.B.Khalid, R.Yusof, "Tuning of a Neuro-Fuzzy Controller by Genetic Algorithm", IEEE Trans. On systems, Man, and Cybernetics-Part-B: Cybernetics, Vol. 29, No. 2, pp. 226-236, Ap. 1999.