

Traffic Light Control System Using Raspberry-PI

¹M.Vidhya, ²S.Elayaraja, ³M.Anitha, ⁴M.Divya and ⁵S.Divya Barathi

¹Assistant Professor, ^{3,4,5}Students, Department of ECE, AVS Engineering College, Salem, Tamil Nadu, India

²Assistant Professor(Sr.G), Department of Civil Engineering, PSG Institute of Technology & Applied Research, Coimbatore, Tamil Nadu, India

E-mail: ¹ vidhyiaksm@gmail.com ² elayaraja86@gmail.com ³ anushasu11@gmail.com, ⁴ 22candydivya@gmail.com ⁵ divyasriajantha@gmail.com

(Received 10 December 2015; Revised 20 December 2015; Accepted 21 January 2016; Available online 29 January 2016)

Abstract - Nowadays congestion in traffic is a serious issue. The traffic congestion can also be caused by large red light delays etc. The delay of respective light is hard coded in the traffic light and it is not dependent on traffic. In this paper we studied the optimization of traffic light controller in a city using microcontroller. The system tries to reduce possibilities of traffic jams, caused by traffic lights, to an extent. The system is based on raspberry-pi. The system contains IR transmitter and IR receiver which are mounted on either sides of roads respectively. Based on different vehicles count, the raspberry-pi takes decision and updates the traffic lights delays as a result. Thus based on vehicles count, raspberry-pi defines different ranges for traffic light delays and updates those accordingly. This recorded vehicle count data can be used in future to analyze traffic condition at respective traffic lights connected to the system. For appropriate analysis, the record data can be downloaded to the controller through communication between raspberry-pi and the computer then it will send correct signal into the LED lights. In future in this system can be used to inform people about different places traffic condition.

Keywords: Traffic control, Raspberry-pi, Image processing, Vehicle counting, Open CV, IR sensor

I.INTRODUCTION

India is the second most populous country in the world and is a fast growing economy. Infrastructure growth is slow as compared to the growth in number of vehicles, due to space and cost constraint. Also, Indian traffic is non-lane based and chaotic. In traffic environments, traffic sign recognition (TSR) is used to regulate traffic signs, warn the driver, and command or prohibit certain actions. Technologies like ZigBee, RFID and GSM can be used in existing traffic control system to provide cost effective solutions. Traffic jams may arise due to large red light delays which are hard coded and is independent of traffic. The proposed system tries to reduced the traffic jams to some extent. We have developed a cost effective system using RASPBERRY-PI kit, IR sensor and latest high speed microcontroller to achieve the desired results. We aim at controlling traffic density using IR sensor. The IR system gets activated whenever any vehicle passes on road between IR transmitter and receiver. Raspberry-pi controls the IR system and counts number of vehicles passing on the road. Raspberry-pi also store vehicles count in its memory. Based on the different vehicle count, the RASPBERRY PI takes decision and update the traffic light delays as a results. It

will give green signal in high density traffic lane, that same time it shows red signal in opposite lane. administrator sitting on computer can command system(Raspberry-pi) to download recorded data, update light delays, erase memory etc. The administrator on a central station computer can access traffic conditions on any approachable traffic lights and nearby roads to reduce traffic congestion to an extent.

II.EXISTING SYSTEM

It can be seen that existing technologies are insufficient to handle the problems of congestion control, emergency vehicle clearance, stolen vehicles detection, it is. In this existing system is used RFID method to avoid the traffic density. List of the components used in this existing system are zigbee module CC2500, microcontroller, GSM module SIM 300, RFID reader-125kHz-TTL.

A. ZIGBEE MODULE : The CC2500 is a RF module and has transceiver, which provides an easy way to use RF communication at 2.4 GHz. Every CC2500 is equipped with the microcontroller (PIC 16F877A), which contains unique identification number (UIN). One of the most important features is serial communication without any extra hardware and no extra coding. It is used to transmit and receive the data at 9600 baud rate. In this existing system uses CC2500 ZigBee module and it has transmission range of 20 meters.

B. MICROCONTROLLER (PIC16F877A) : Peripheral Interface Control (PIC) executes each instruction in less than 200 nanoseconds. It has 40 pins and has 8K program memory and 368 bytes data memory. It is easy to store and send UINs. At the junction, it is easy to store large number of emergency vehicles. Before switching to green, it should satisfy all the conditions. It consumes less power and operates by vehicle battery itself without any extra hardware.

C. GSM MODULE SIM 300 : Here, GSM modem is connected with the microcontroller. This allows the computer to use the GSM modem to communicate over the mobile network. GSM modem must support "extended command set" for sending/receiving SMS messages. SIM 300 is designed for global market and it is a tri-band GSM engine. It works on frequencies EGSM 900 MHZ, DCS 1800 MHZ and PCS 1900 MHZ. SIM 300 features GPRS

multi-slot class 10/class 8(optional) and supports the GPRS coding schemes. This GSM modem is a highly flexible plug and play quad band GSM modem, interface to RS232, it supports features like voice, data, SMS, GPRS and integrated TCP/IP stack.

D. RFID READER-125 KHZ-TTL : Radio Frequency Identification (RFID) is an IT system that transmits signals

without the presence of physical gadgets in wireless communication. It is categorized under automatic identification technology, which is well established protocol. The reader reads the radio frequency and identifies the tags. RFID range depends on transmit power, receive sensitivity and efficiency, antenna, frequency, surroundings, tag orientations. RFID reader uses frequency 125 KHZ with a range of 10 cm.

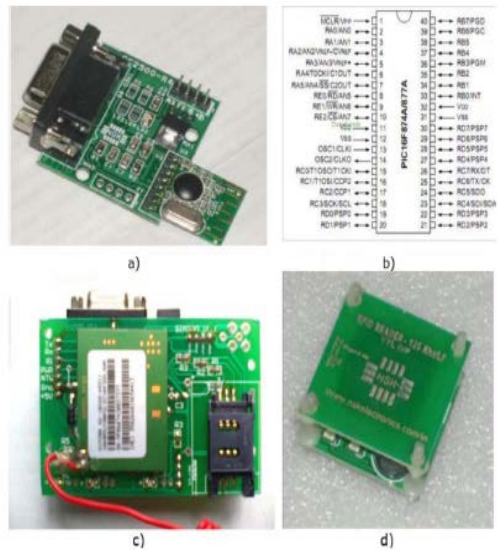

Fig:1 a) ZigBee, b) Microcontroller, c) GSM module, d) RFID Reader

E. DRAWBACKS OF EXISTING SYSTEM

1) PIC microcontroller is used in this existing system, so the server is cannot access in this microcontroller. 2) These systems are very insufficient because they are unable to handle various simple situations which are occurs through the day. 3) Major drawback is it has unnecessary waiting time and there no facility to handle emergency vehicles. 4) RFID systems are expensive in comparison to normal bar code systems.

the road with higher density of vehicles. Through which less number of vehicles in waiting state and can reduce time consuming. And our system also provides the clearance for the emergency vehicle if any. For example fire emergency, ambulance emergency etc. The system is based on the AVR microcontroller technology. The code for this project is compiled in high tech PYTHON programming.

III.PROPOSED SYSTEM

The existing system based on the "time" which is already assigned in the system. According to those "time" the signals are working in each lane. But in these system condition is occurs as all vehicles in lane(L1) are passed and vehicles in another lane(L2) still in waiting state because time is not over and hence signal is still red. These systems are very inefficient because they are unable to handle various simple situations which are occurs throughout the day. Major drawback is it has unnecessary waiting time. We propose a smart traffic signal controller system. The proposed system tries to minimize the possibilities of traffic jams, caused by the traffic lights, to some extent by clearing

Complete system of automative traffic control system separated in following seven stages:

1. Image acquisition : Image of the vehicle is captured using video camera and transferred to the image processing system in open CV.
2. Image pre-processing : Acquired image is enhanced using contrast and brightness enhancement techniques.
3. Grayscale conversion : It involves conversion of colour image into a gray image. This method is based on different colour transform. According to the R,G,B value in the image, it calculates the value of gray value, and obtains the gray image at the same time.
4. Image Binarization : Grayscale image is converted into black and white image i.e. binary image using thresholding option.

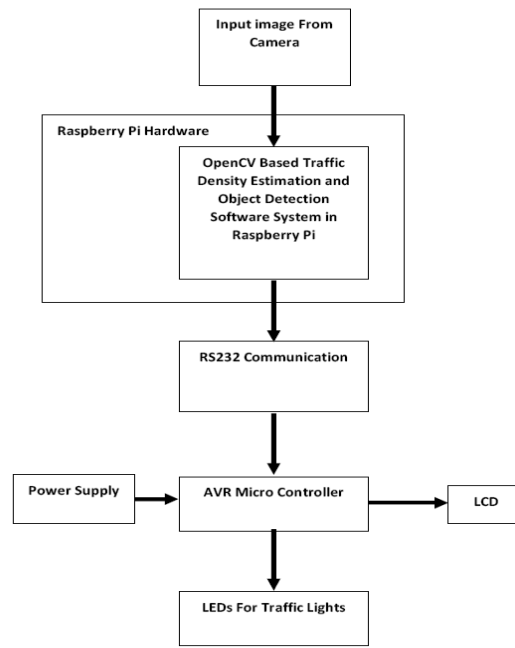

Fig:2 Architecture of proposed system

1. Traffic density calculation : By applying Morphological filtering and Blob analysis on the binary image number of vehicles will be count and compare with traffic density threshold.
2. Identify ambulance : By using Binary image, Morphological filtering and Blob analysis ambulance will detected.
3. Send ambulance signal to the Raspberry-pi: The identified ambulance signal is send to raspberry -pi kit and it will change the signal.

A. BLOCK DIAGRAM

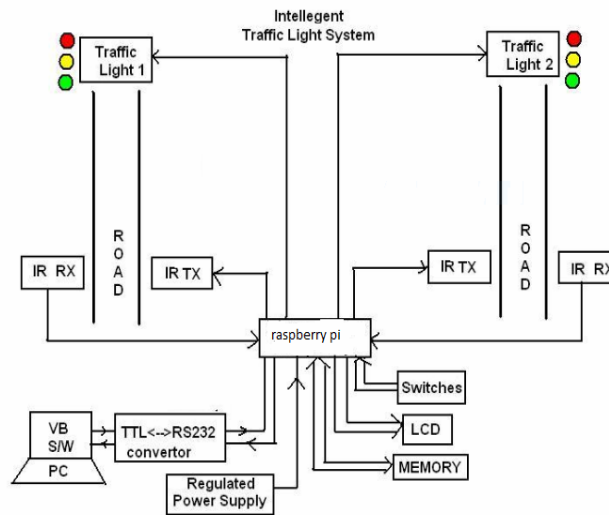

Fig:3 Block diagram

B.PROPOSED SYSTEM FLOW

Proposed system flow is shown in the figure:

- a) Camera : Continuously record traffic video.
- b) Read image : Take one Frame per second from video using image processing.
- c) Image Subtraction : In system we already save background image without vehicles (initial condition) and subtracts current image of traffic from background image.
- d) Convert image to binary : Creates black and white image
 - vehicle = white , background = black
- e) Morphological processing : It performs image filtering

- open: Remove white dots other than vehicle
 - close : Remove black dots other than background
- f) Blob analysis:

- a. Checks current density of vehicle
- b. Checks tags on vehicle if any

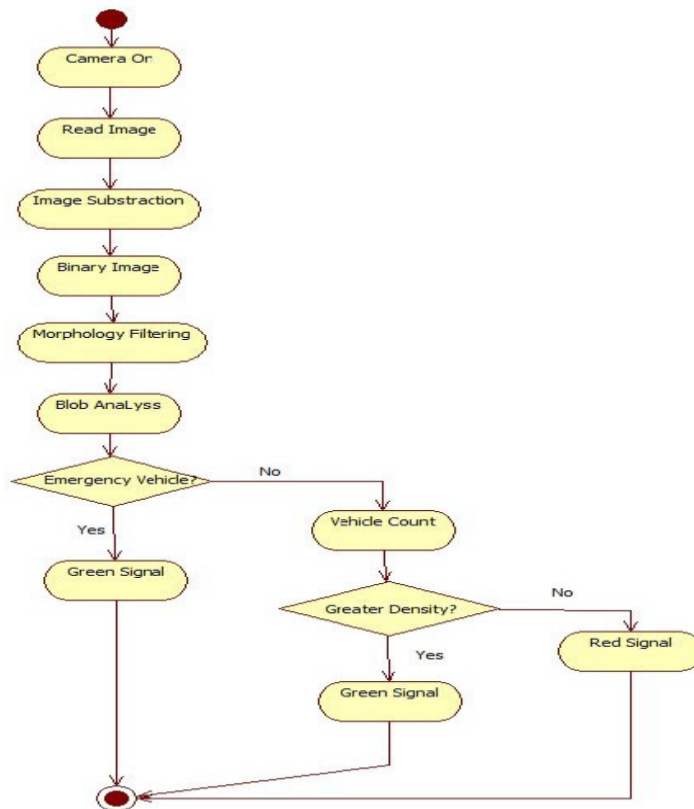

Fig:4 Proposed system flow

- g) Find the vehicle emergency or not:
- a. Verify emergency vehicle is present or not
 - b. If present emergency vehicle then generates green signal
 - c. Opposite side have red signal Greater density lane = green signal , other lane = red

IV.HARDWARE SPECIFICATION

- A) Raspberry-pi device : The Broadcom SoC used in the raspberry-pi is equivalent to a chip used in an old smart phone. While operating at 700 MHZ by default, the Raspberry-pi provides a real world performance roughly equivalent to the 0.041 GFLOPS on the CPU level the performance is similar to 300 MHZ Pentium of 1997-1999. The GPU provides 1 Gpixel/sof general purpose computing performance. The raspberry-pi chip will not become hot enough to need a heat sink. The default split was 192 MB (CPU RAM), which should be sufficient for standalone 1080p video decoding or for simple 3D but probably not for both together. 224 MB was Linux only, with just a 1080p frame buffer, and was likely to fail for any video or 3D. 128 MB was heavy 3D, possible also with video decoding.
- B) IR sensor : This IR sensor detects vehicle and also detect the emergency vehicle. Thermal radiation is emitted by all the objects in the infrared spectrum. The infrared sensor detects is type of radiation which is not visible to human eye. Use of IR LEDs to send the

infrared waves to the object. Another same type IR diode is to be used to reflected wave from the object.

- C) Power supply : As per the power requirement of the hardware in traffic light control system using raspberry-pi is required power supply of 5V with respect to Ground.
- D) Liquid Crystal Displays (LCD) : The voltage needed is preferable 2-20 V in A.C. The threshold voltage for watch type LCD displays is 1 to 2V. It is a 16 pin device with 16*2 displays. LCD is consists two modes N (normal mode) and C (high density). All time it displays NNNN for the four lanes, depicting a NO traffic density. The moment there is traffic density it displays CNNN, means that lane 1 has traffic density and requires to be cleared.
- E) TTL<->RS 232 converter : The complete circuitry is operated with TTL logic level of 0-5V. It comprise of 0V to 9V transformer to step down the 220V AC supply to 9V DC. Further bridge rectifier converts the 9V into 9V (2)^{1/2} DC. It is further filtered through a 1000uF capacitor and then regulated using 7805 to get +5V.

V.SOFTWARE SPECIFICATION

- A) Open CV : Open CV stands for Open computer vision it is source library of functions. Open CV is released under a BSD license hence it is free for both Academic and Commercial used and open

source library written in c/c++. Open CV support many languages like C, Perl, Ruby. It is originally developed by Intel. Mainly aim at real-time computer vision It is a cross platform (Linux, OS X, Win2K, Win XP).

- B) Visual Studio : Microsoft visual studio is an integrated development environment [IDE] from Microsoft. It support different programming language and allows code editor and debugger to support nearly any programming language and provide language specification service. Also visual studio generate native an managed code.
- C) Raspbian OS : Raspbian is free OS based on debian optimized for the raspberry device an operating system is the set of basic programs and utility that your raspberry-pi run. Rapsbian provides more than a pure OS it's comes with over 35000 packages. precompiled software bounded in easy format of installation on your Raspberry pi device.

VII.FUNCTIONS

1)Turning ON-OFF of Traffic lights in sequence. 2) Control for ambulance-receiving the signal from RF receiver and making the respective lane's traffic light green. 3) Control for VIP vehicles-receiving the signal from IR receiver and making the respective lane's traffic light green. 4) Density control -receiving signal from IR receivers and changing the delay of traffic light green signal from 6sec to 12sec. 5) Sending message to LCD pins so that it displays the right information on screen

Advantages of proposed system:

- 1) This system reduces the overheads on the database server, by deleting the data after every 4 hours automatically. 2) This system reduces the waiting time as traffic signals light will change according to density. So it also reduces traffic jams. 3) Number of road accidents can be reduced to a large extent.4) This modernized way of controlling traffic system is help the traffic police in easy control of traffic.

VIII.CONCLUSION

This proposed system reduces the possibilities of traffic jams, caused by high red light delays and provides the

clearance to the emergency vehicle, to an extent successfully. In this system, we find the traffic density using Morphological filtering Blob analysis. The roads highest priority is cleared first. The proposed system also gives importance to the ambulance. If any ambulance is waiting in a signal then the particular lane is given high priority and the traffic in that lane is cleared. Whenever emergency vehicle enters the lane, by using camera image, Morphological filtering and blob analysis detects vehicle and sends signal it to microcontroller and raspberry-pi. The raspberry-pi gives high priority to the emergency vehicle and clear the traffic density depends on python programming.

VIII.FUTURE SCOPE

- 1. Blinking of traffic signal light according to the traffic level present on the road
- 2. This system manages traffic when any emergency vehicles come. For example ambulance, fire bridged etc.
- 3. Proposed system will have wider future scope that user can get traffic information on mobile phone

REFERENCES

- [1] Rajasheswari sunder, Santhoshs Hebber , and varaprasad Golla, Implimenting intelligence Traffic control system for congestion control, Ambulance Clearness, and Stolen Vehicle Detection " IEEE Sensors Journal, Vol. 15, No.2 February 2015.
- [2] M.Vidhyia, K.Paramasivam, S.Elayaraja, S.Bharathiraja Reordering of Test vectors using weighting factor based on Average power for test power Minimization, Vol.4, No.2, 2015, pp.10-15
- [3] Raspberry pi Web page:Https://en.wikipedia.org/wiki/Rasspberry-pi [NOV 2015].
- [4] K.Vidhya, A.Bazila Banu, "Density Based Traffic signal System" , Volume 3, Special Issue 3, March 2014.
- [5] Priyanka Khanke, prof. P.S.Kulkarni, "A Technique on Road Traffic Analysis using Image Processing", Vol. 3 Issue 2, February 2014.
- [5] Ms. Pallavi Choudekar, Ms. Sayanti Banerjee Prof. M.K. Muju, Real Time Traffic Light Control Using Image processing " Vol.2, No. March 2014.
- [6] R. Nithin Goutham1, J. Sharon Roza2, M.Santhosh3, Intelligent signal control system, Vol.3, Special Issue 4, May 2014.
- [7] S. Lokesh, T. Prahald Reddy, An Adaptive Traffic Control System Using Rasspberry pi, Vol 3(6): June, 2014
- [8] Traffic Management Centre. [online]. Available: <http://www.bangaloretrafficpolice.gov.in/index.php?option=com-content&view=article&id=87&btp=87>, accessed 2014.