

Robotic Arm Control through Human Arm Movement Using Accelerometer

Adeeb Ahammed P¹ and K Edison Prabhu²

¹P.G scholar, M.E(Embedded System technologies), ²Assistant Professor,

Department of Electronics and Electronics, Nehru Institute of Engineering and Technology, Coimbatore, Tamil Nadu, India
E-mail: adeebahammed23@gmail.com

(Received 17 February 2016; Revised 1 March 2016; Accepted 31 March 2016; Available online 8 April 2016)

Abstract-In today's world there is an increasing need to create artificial arms for different inhuman situations where human interaction is difficult or impossible. Here we propose to build a robotic arm controlled by natural human arm movements whose data is acquired through the use of accelerometers. The development of this arm is based on a accelerometers, which will all be interfaced with the microcontroller. Finally, this prototype of the arm may be expected to overcome the problem such as placing or picking hazardous objects or non-hazardous objects that are far away from the user.

Keywords: Accelerometer, robotic arm ,Microcontroller.

I.INTRODUCTION

Nowadays, robots are increasingly being integrated into working tasks to replace humans especially to perform the repetitive task. In general, robotics can be divided into two areas, industrial and service robotics. International Federation of Robotics (IFR) defines a service robot as a robot which operates semi- or fully autonomously to perform services useful to the wellbeing of humans and equipment, excluding manufacturing operations. These robots are currently used in many fields of applications including office, military tasks, hospital operations, dangerous environment and agriculture. Besides, it might be difficult or dangerous for humans to do some specific tasks like picking up explosive chemicals, defusing bombs or in worst case scenario to pick and place the bomb somewhere for containment and for repeated pick and place action in industries. Therefore a robot can be replaced human to do work.

A robotic arm is a robot manipulator, usually programmable which can perform similar functions to a human arm. The parts of the manipulators are connected by joints allowing either rotational motion or translation. There are many different types of robotic arms made for different purposes having different degrees of freedom, architectures and applications. But many of them are manufactured to fulfil one particular purpose in Industry level applications. The procurement and establishment of such different robotic arm for different purposes is usually a big headache and time taking process. To minimize the efforts, often different modifications and improvements are made by manufacturers to increase the domain of its applicability. This also increases the cost and complexity of the system.

The present model is a novel implementation of robotic arm control through human arm movement using accelerometer. The micro-controller which acts as the main controller guides all the movements of the robotic arm and acts as the brain of the system.

II EXISTING SYSTEM

There are various ways in which a robotic arm may be controlled. In the past there have been many researchers working to control robotic arm through computer terminals, Joysticks etc.Usually most of the robotic arms are controlled by a central controller which makes uses of values taken in from the terminal that are entered by the user at the terminal to move the arm to a particular coordinates in space. This makes the control very difficult as the control values of the motors are very difficult to predict to achieve a particular movement. This is easily achieved by our project. This Project represents a simple accelerometer controlled robotic arm using microcontroller powered embedded system as the core of this robot . The robot does not require training because the robotic arm is fully controlled by the user.

III. SYSTEM DESIGN

A. Hardware design A three axis accelerometer is used in the control unit. Another analog device accelerometer is strapped to the user arm. GPRS transceivers are used for wireless transmission and reception of data. The data processing is carried using low cost microcontroller rather than digital signal processing. PIC microcontroller was used for data processing one in control unit and one at the receiving end to control the robotic arm.

B. Control unit The prototype for a control unit is built with the PCB board, microcontroller, accelerometer and Gprs module. The accelerometer can be strapped to the user arm. The user arm can be moved and the data are measured by the microcontroller from the sensor and send these values to the Gprs transceiver. All the measured readings were transmitted from the microcontroller to the Gprs transceiver.

C. Electronic Circuit Design The electronic part is used to control the movement of the arm component. For this purpose, pic is the microcontroller is used. The pic needs to have its own electronic circuit and needs to be programmed

to enable it to control the arm movement and interface with the software to control the arm.

D Communication System This part is the heart of the entire project. Without an effective and reliable communication system, no system / project can work. Similar is the case with this project also. The GPRS

Module, is the only communication equipment required in this project. This Module is used to transmit the different hand gestures made by the user (encoded in the form of 4-bit digital data) wirelessly to the receiver which decodes the received 4-bit digital data and according to which the arm, moves. The block diagrams shown in Figure are of Transmitter End and the Receiver End.

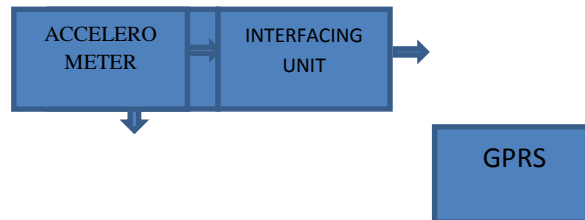

Fig.1 Receiver Part

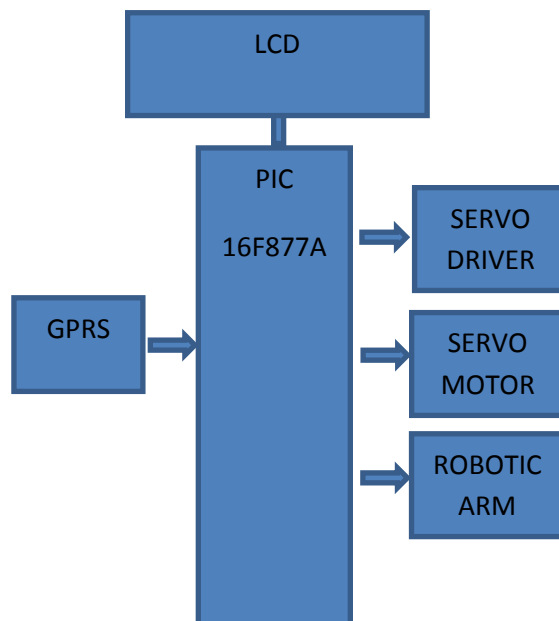

Fig.2 Transmitter Part

IV. TECHNICAL REQUIREMENTS

The technical requirements chosen as a basis for the efficient functioning of the system are as follows:

A Microcontroller PIC 16F877A microcontroller is used as the hardware platform. It is the controlling unit, to which all other components (Accelerometers, Motors, GPRS modules etc.) are interfaced. Two such microcontrollers are used in this project, one at the Transmitting end and one at the Receiving end.

B.GPRS module The native communication task between the Robotic Arm, Platform and the different hand and leg

gestures of the user is done by this module via GPRS signals.

C Accelerometer An accelerometer measures gravitational force or acceleration. By tilting an accelerometer along its measured axis, one can read the gravitational force relative to the amount of tilt. Most accelerometers available today are small surface mount components, so you can easily interface them to a microcontroller. The accelerometer that is used here consist of three axis X,Y,Z.

D Servo Motor A servo motor consists of several main parts, the motor and gearbox, a position sensor, an error amplifier and motor driver and a circuit to decode the

requested position. The radio control receiver system (or other controller) generates a pulse of varying length approximately every 20 milliseconds. The pulse is normally between 1 and 2 milliseconds long. The length of the pulse is used by the servo to determine the position it should rotate to. The current rotational position of the servo motor output shaft is read by a sensor. This is normally a

potentiometer (variable resistor) which produces a voltage that is related to the absolute angle of the output shaft. The position sensor then feeds its current value into the Error Amplifier which compares the current position with the commanded position from the pulse width to voltage converter.

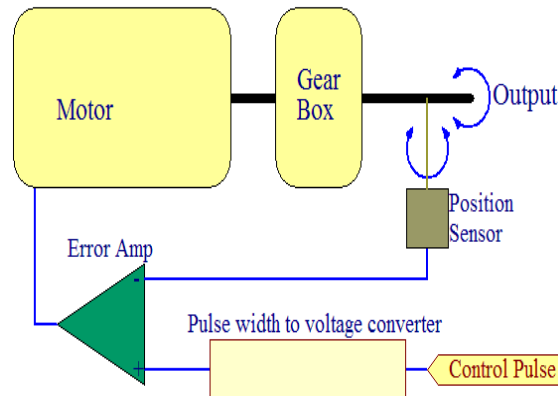

Fig 3 Servo Motor

V. SIMULATION RESULT AND DISCUSSION

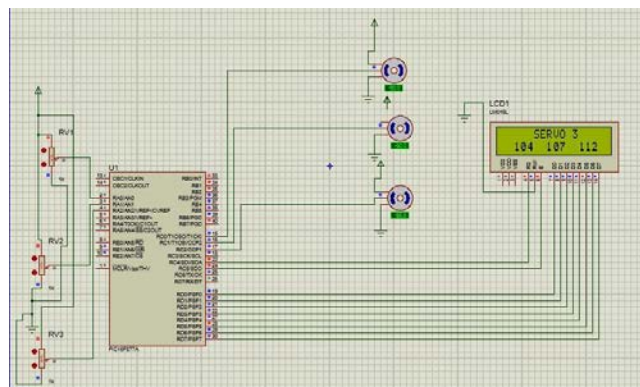

Fig 4 .simulation result of the project gesture based robotic arm control.

The above figure shows the simulation result of the project gesture based robotic arm control. Here simulation model shows the exact working of the robotic arm with the help of gesture. The gesture signals are given as the input signals(X,Y,Z).The accelerometer will receive the signals and pass to microcontroller as shown in the fig 6.1.if the value exceeds value 100 the motor will start rotating -90 and if the value comes below 100 the motor will rotate +90.the same process will be repeated for the other two motors.

VI. CONCLUSION

The progress in science and technology is a nonstop process. New things and new technology are being invented. As the technology grows day by day we can imagine about the future in which thing we may occupy

every place. The objectives of this project has been achieved for an accelerometer controlled robotic arm. From the observation that has been made, it clearly shows that its movement is precise, accurate, and is easy to control and user friendly to use. The robotic arm has been developed successfully as the movement of the robot can be controlled precisely. This robotic arm control method is expected to overcome the problem such as placing or picking object that away from the user, pick and place hazardous object in a very fast and easy manner. The proposed system based on microcontroller is found to be more compact, user friendly and less complex which can readily be used in order to perform the task in day today life.

REFERENCES

- [1] Avinash Jain, "Servo Motor Control by Using AVR ATmega32 Microcontroller", <http://extremeelectronics.co.in/avr-tutorials/servo-motor-control-by-using-microcontroller/>, June 2010
- [2] Avinash, "Using LCD Modules with AVR", <http://extremeelectronics.co.in/avrtutorials/using-lcd-module-with-avrs/>, July 2008
- [3] Avinash, "Using ADC on AVR", <http://extremeelectronics.co.in/avr-tutorials/using-theanalog-to-digital-converter/>, September 2008
- [4] Avinash, "Using the USART of Microcontrollers", <http://extremeelectronics.co.in/avrtutorials/using-the-usart-of-avrmicrocontrollers/>, December 2008
- [5] Design and Implementation of a Wireless Controlled Robotic Arm with Vision International Journal of Computer Applications (0975 – 8887) Volume 79 – No 13, October 2013
- [6] Mohd Ashiq Kamaril Yusoffa, Reza Ezuan Saminb, Babul Salam Kader Ibrahimc, "Wireless Mobile Robotic Arm", International Symposium on Robotics and Intelligent Sensors 2014(IRIS 2014), July 20124
- [7] Remote Monitoring and Control of Robotic Arm with Visual Feedback using Raspberry Pi International Journal of Computer Applications (0975 – 8887) Volume 92 – No.9, April 2014.
- [8] Wan Muhamad Hanif Wan Kadir, Reza Ezuan Samin, Babul Salam Kader Ibrahim, "Internet Controller Robotic Arm". International Symposium on Robotics and Intelligent Sensors 2013(IRIS 2012), July 2013