

Comparison of Different PWM Techniques in T-Source Inverter

T.Rama Rajeswari¹, G.Hemaprabha², T.Rajesh³, P.Sivaraman⁴

¹PG Student [PED], ^{2,3}Assistant professor,

Dept. of EEE, Info Institute of Engineering, Coimbatore, Tamil Nadu, India

⁴ Professor, Dept. of EEE, Bannari Amman Institute of Technology, Erode, Tamil Nadu, India

Email: ramarajeswari.kannan@gmail.com

(Received 18 June 2015; Revised 5 July 2015; Accepted 30 July 2015; Available online 12 August 2015)

Abstract - This paper deals with the analysis of three phase T-source inverter by using different control techniques to minimize the switching losses. T-source impedance network is developed to overcome the drawbacks of Z-source inverter. T-Source inverter has low reactive components in comparing with ZSI. The Total harmonic distortion (THD) of output voltage for both the control methods has been analyzed by using FFT analysis. The maximum constant boost pulse width modulation (PWM) control method has more voltage gain and less voltage stress compared to other techniques. The experiments are done and the results are shown for capacitor voltage, load current and load line voltage for simple boost, constant boost control technique and space vector modulation PWM techniques are presented using MATLAB/Simulink.

Keywords: Z-source inverter, T-Source inverter, simple boost control, maximum constant boost control, Shoot-through control, THD

I. INTRODUCTION

The inverter is the power electronics circuit, which converts the DC voltage into AC voltage. Inverters are broadly classified into two types. They are Voltage source inverter (VSI) and Current source inverter (CSI). VSI is fed from a DC voltage source having a small or negligible impedance. Dead time is needed to protect the upper and lower switching devices in each phase leg from short circuit. CSI is fed with adjustable current from a DC voltage source of high impedance. Overlap time between phase legs are compulsory to avoid the open circuit of upper or lower switching devices. These problems are overcome by Z – source inverter and quasi Z – source inverter. The T-Source Inverter topology can require a very less leakage inductance transformer which should be made with high accuracy. In T-source inverter, only the transformer and the capacitor are needed by reducing the number of passive elements. When both switches in the same phase leg are turned on by the TSI can handle shoot-through states. The LC-network is replaced by using the T-network. A T - source inverter is used for boosting the output voltage by inserting shoot through states in the PWM.

II. Z-SOURCE INVERTER

The impedance-source or Z-source inverter has been newly invented eliminates all problems of the traditional Voltage source and current Source inverter. It is being used in AC/DC power conversion applications. It employs the unique impedance network, which is used to couple the converter main circuit to the power source (may be VSI or CSI), load, or another converter. The impedance network consist of two inductors (L_1, L_2) and two capacitors (C_1, C_2) are connected in X-shape. The values of both inductors and capacitors are equal. The impedance network is the energy storing element for the converter. In 3-phase converters, a voltage-fed Z-source converter has a unique feature of allowing both the upper and lower power switches of the same phase-leg to be turned ON simultaneously without damaging the converter.

III. T-SOURCE INVERTER

The T –source inverter (TSI) overcome the drawbacks of traditional voltage source and current source inverters. The T-source inverter can perform DC to AC conversion and buck boost operation in a single stage. TSI has low reactive components. For these reasons, the efficiency significantly increases. Unlike the traditional inverter, TSI has a unique impedance network that link the inverter main circuit to the DC source. The passive element of inductor and capacitor is reduced in the T - source inverter (TSI). When compared to Z-source inverter, two capacitors is used. In T-source inverter, only one capacitor is used. It should be made with high accuracy. TSI has a common DC rail between source and inverter. The impedance network output is applied to the inverter circuit and the inverter circuit consists of six switches. From the Shoot through mode of switches operation is achieved the Boosting capability. Simultaneously, this operation performed by turning on the both switches.

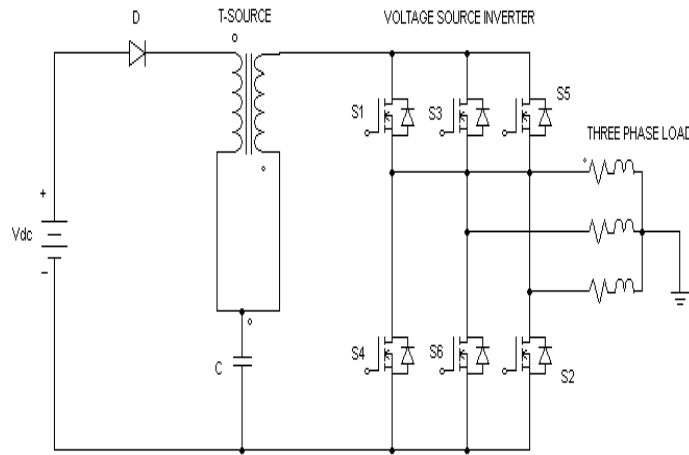

Fig. 1 Circuit diagram for T-source Inverter

A. Principle of operation

T-source inverter consists of two operating modes. One is Shoot through mode and another one is Non Shoot-through mode. In the PWM, T-network is used instead of the LC-network for boosting the output voltage by inserting shoot through States.

B. Shoot through mode

It can be obtained in three different ways, such as shoot through via one phase leg or combination of two phase legs. when both switches of the same phase leg are going to one state then the TSI can handle shoot through States. In Shoot through mode, the diode is reverse biased and it separates the DC link from AC line. By controlling the shoot through time the desired output voltage is obtained.

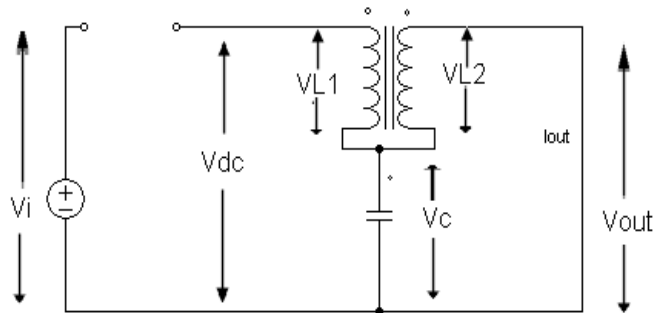

Fig. 2 Equivalent Circuit of shoot through state

C. Non Shoot through mode

Non shoot through mode is also called as active (or) traditional mode. During active mode of operation, the input voltage appearing across the capacitor, no voltage appears across the inductors; only a pure DC current flows through

the inductors and the voltage gets impressed across the load. The diode conducts and carries the current difference between the inductor current and input DC current. Because of coupled inductors, the current should be identical in the inductor.

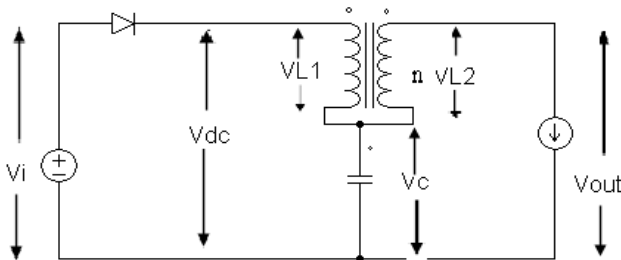

Fig.3 Circuit of non-shoot through State

D.Design Of T – Source Inverter

Design of TSI the most challenging is the estimated value of the reactive components of the impedance network. The component values should be calculated for the minimum input voltage of the converter. The boost factor and the current stresses of the components become maximal.

The average current of an inductor is calculated by,

$$I_L = \frac{P}{V_{DC}} \tag{1}$$

During maximum shoot-through mode, the maximum current flows through the inductor which causes maximum ripple current. During maximum power operation, 60% of peak-to-peak current ripple through the Z-source inductor. Therefore, the allowed ripple current is ΔI_L , and the maximum current through the inductor is I_{Lmax} .

$$I_{LMAX} = I_L + \Delta I_L \tag{2}$$

$$I_{LMIN} = I_L - \Delta I_L \tag{3}$$

$$\Delta I_L = I_{LMAX} - I_{LMIN} \tag{4}$$

The boost factor of the input voltage is

$$B = \frac{1}{1 - 2D_z} \tag{5}$$

Where D_0 is the shoot through duty cycle

$$D_z = \frac{B - 1}{2B} \tag{6}$$

The features of T – Source inverter is given below,

- a. Low reactive components are used.

- b. Using common voltage source and passive arrangement.
- c. Reducing the number of switching devices.
- d. Dead time is not needed. Inrush current the harmonics can be reduced by inductors.

IV. PWM TECHNIQUES

To control T-source inverter there are a number of control methods. The Pulse Width Modulation control algorithms are

- a. Simple Boost Control (SBC)
- b. Maximum Boost Control (MBC)
- c. Maximum Constant Boost Control (MCBC)
- d. Space Vector PWM (SVPWM)

The modulation index is also defined as the amplitude modulation ratio (M) which is the main control factor. It is defined as the fraction of amplitude of reference wave to the amplitude of carrier waves.

$$M = V_{ref} / V_{ca} \tag{7}$$

Between modulation index and the output voltage, the linearity is achieved by under the modulation index ($M < 1$).

A. Simple Boost Control Method

At SBC, the shoot-through periods are hosted by two straight lines which are equal or greater than the peak values of the modulating reference sinusoidal signals. Compare the DC signal (with equal magnitude or greater than the triangular signal peak) and the high frequency triangular carrier signal, the shoot-through switching pulses are produced. These two signals can be compared using a comparator (while $V_{sin} > V_{tri}$, on and $V_{sin} < V_{tri}$, off). Using logical OR gate, the Shoot-through pulses are implanted into the switching waveforms.

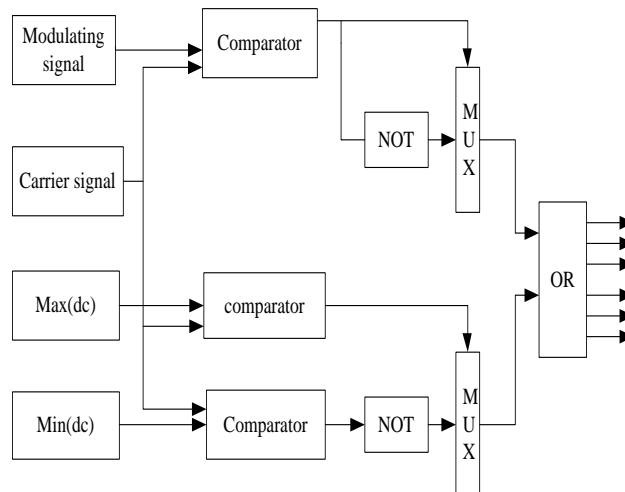

Fig.4 Block Diagram of SBC

Shoot through duty ratio : $D_0 = 1-M$ (8)

Boost Factor : $B = \frac{G}{M}$ (9)

Gain Factor : $G = \frac{M}{1-2D_0}$ (10)

The maximum voltage gain is required to produce an output voltage by a small modulation index. However, small modulation index result in greater voltage stress on the devices. Using this control method, voltage stress across the switches is high, which will restrict the available voltage gain because of the limitation of device voltage rating.

B. Maximum Constant Boost Control Technique

In order to reduce the volume and cost, it is important always to keep the shoot-through duty ratio constant. At the

same time, high voltage boost for any given modulation index is chosen to reduce the voltage stress across the switches. The control method consists of five modulation curve in which there are three reference signals (VA, Vb, Vc) and two shoot-through envelope (Vp and Vn). When the carrier triangle wave is greater than the upper shoot-through envelope Vp or lower than the lower shoot-through envelope Vn then the inverter is turned to zero state of shoot-through. MCBC achieves maximum boost while keeping the shoot through duty ratio always constant, it results in no line frequency current ripple through the inductors. Third harmonic injection is commonly used in a three-phase inverter system to increase the Modulation index range.

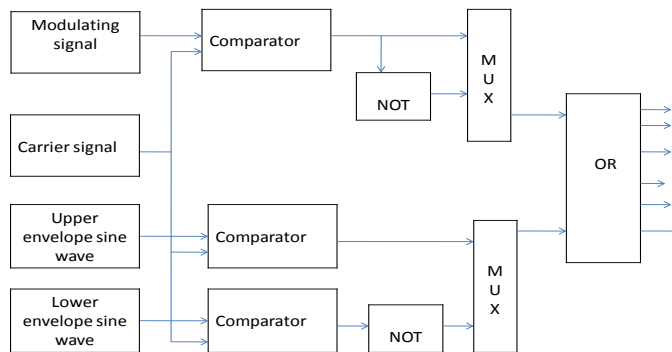

Fig.5 Block diagram of MCBC

$$M = \frac{v_{ref}}{v_{car}} \tag{11}$$

$$D_0 = 1 - \frac{\sqrt{3}}{2} M \tag{12}$$

$$B = \frac{1}{\sqrt{3}M - 1} \tag{13}$$

$$G = BM \tag{14}$$

This method will cause a slightly higher voltage stress across the devices than the maximum control method, but abundant lower voltage stress than the simple control method.

C. Space vector pulse width modulation technique

The space vector modulation technique has eight vectors. It consists of Six non-zero vectors (V_1-V_6) and two zero vectors (V_0-V_7).Space vector modulation technique is used to reduce the harmonics and to control the output voltage. In this technique is to estimate the reference voltage vector V_{ref} .

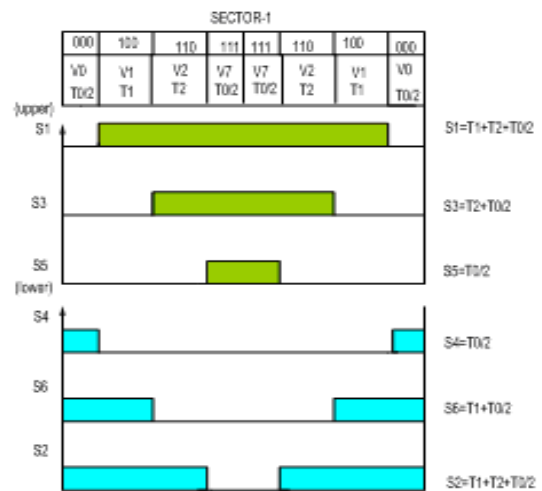

Fig.6 space vector modulation technique

V. SIMULATION RESULTS

Table I shows the T-source inverter used for the simulation with turns ratio one and Table. 2 show the comparison of various PWM techniques.

TABLE I SYSTEM PARAMETERS

S.No.	Parameters	Values of simulation
1	DC supply voltage	100V
2	T-source capacitance	360nF
3	T-source mutual Inductance	0.2mH
4	Transformer turns ratio	1.1
5	Switching Frequency	7.2kHz

TABLE. II COMPARISONS OF VARIOUS PWM TECHNIQUES

Parameters	SBC	MCBC	SVPWM
Output voltage(V)	190	210	220
THD (%)	10.48	17.73	2.78
Modulation Index(M)	0.8	0.8	0.8
Shoot through duty ratio (D_o)	0.2	0.31	0.30
Gain (G)	1.33	2.59	2.52
Boost Factor (B)	1.66	2.09	2.01

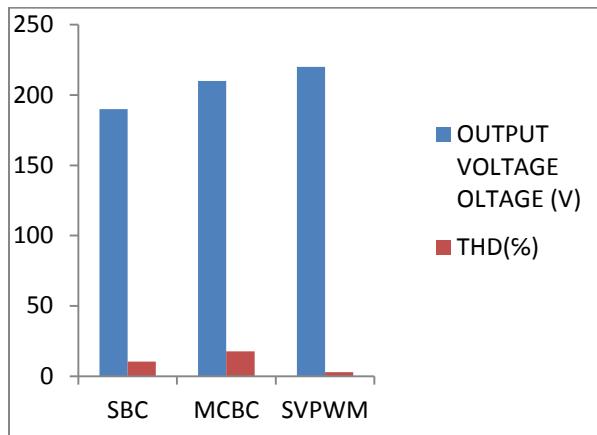

Fig.7 comparisons of various pwm techniques

VI. CONCLUSION

This paper fully deals with analyzing the performance of TSI under various PWM techniques like simple boost control (SBC), Maximum constant boost control (MCBC). For all those above mentioned PWM techniques, the voltage boost is inversely related to shoot-through duty ratio. Under lower modulation index, SBC has lower voltage gain, MCBC gives a higher voltage gain, but has higher ripple content, whereas MCBC provides better voltage gain and its ripple content is low comparing to SBC. When it is compared with all other control Methods, the Space vector pulse width modulation (SVPWM) technique has much lower voltage stress across the devices and reduced harmonics.

REFERENCES

- [1] S.Thangaprakash, A. Krishnan “Implementation and Critical Investigation on Modulation Schemes of Three Phase Impedance Source Inverter” *Iranian Journal of Electrical & Electronic Engineering*, 88 Vol. 6, No. 2, June 2010
- [2] Poh Chiang Loh, D. Mahinda Vilathgamuwa, YueSen Lai, Geok Tin Chua, and Yunwei Li, “ Pulse - Width Modulation of Z – source Inverters” *IEEE Transactions on Power Electronics*, Vol. 20, No. 6, November 2005.
- [3] Sivaraman.P, A. Nirmalkumar, “ Modelling and Simulation of Photovoltaic Array fed T-Source Inverter” in *International Conference on Sustainable Energy and Intelligent System*, 2011.
- [4] Sivaraman.P, A. Nirmalkumar, “Analysis and Implementation of Novel TSI for High Voltage Gain Application” in *International Review on Modelling and Simulations*, 2010

- [5] Sivaraman.P, A. Nirmalkumar, "Analysis of T-Source Inverter with Various PWM Schemes" in *European Journal of Scientific Research*, Vol.71 No.2 , pp. 203-213,2012
- [6] F. Z. Peng: *Z-Source Networks for Power Conversion*, Proc. of 23rd Annual IEEE APEC'08, 2008, pp. 1258-1265
- [7] F.Z. Peng, "Z source inverter", *IEEE Trans. IndustryApplications*, vol. 39, no. 2, pp. 504-510, March/April 2003.
- [8] J. Rabkowski, R. Barlik, and M. Nowak, "Pulse Width Modulation methods for bidirectional/high-performance Z-source inverter", *IEEE Power Electronics Specialists Conference*, pp. 2750 –2756, June 2008.
- [9] Marek Adamowicz, Natalia Strzelecka and Wieslaw Bury "Newtype T-source inverter" *In proceeding on international conference of compatibility in power Electronics-2009* pp-191-195.
- [10] Sivaraman P and Nirmalkumar A, "Analysis and implementation of a novel T-source inverter for high voltage gain application" *International Review of Modeling and Simulation* vol.5 pp 818-825 April 2012 ISSN 1974-9821.
- [11] Power Electronics Circuits, Devices and applications by M.H Rashid, 3rd edition, Pearson Education – 2004
- [12] F. Z. Peng, "Z-source inverter", *IEEE Transactions on Industry Applications*, Vol. 39, No. 2, pp. 504-510, 2003
- [13] F. Z. Peng, M. Shen, Z. Qian, "Maximum boost control of the Z-source inverter", *IEEE Transactions on Power Electronics*, Vol. 20, No. 4, pp.833-838, 2005
- [14] P. C. Loh, D. M. Vilathgamuwa, Y. S. Lai, G. T. Chua, Y. Li, "Pulsewidth modulation of Z-source inverters", *IEEE Transactions on Power Electronics*, Vol. 20, No. 6, pp. 1346-1355, 2005
- [15] K.Mahendran "Modified SVPWM For Modified ZSI" *International Journal* Dec 2011
- [16] Auzani Jidin , "Matlab/Simulink based analysis of voltage source Inverter with Space vector Modulation
- [17] B. Hariram, and Dr. N.S. Marimuthu, —Space Vector Switching Patterns for different applications -A Comparative Analysis, *IEEE, International Conference on Industrial Technology (ICIT 2005)* page(s): 1444 -1449, 4-17 Dec.2005, Print ISBN: 0-7803-9484-4/05/\$20.00 ©2005 IEEE
- [18] D. Rathnakumar, Lakshmana Perumal, and T. Srinivasan, —A New Software Implementation of Space Vector PWM, *IEEE, Proceedings of Southeast Conference*, page(s): 131 –136, 8-10 April 2005, Print ISBN: 0-7803-8865-8/05/\$20.00 ©2005 IEEE.