

Certain Investigations on Edge Fed Microstrip Patch Array Antenna for WiMAX Applications

M.Ramya¹, V.Parthipan², and M.Yogadeepan³

^{1,2} Assistant Professor, Department of Electrical and Electronics Engineering, Erode Sengunthar Engineering College, Erode, Tamil Nadu, India

³ Assistant Professor, Department of Electrical and Electronics Engineering, J.K.K.Munirajah College of Technology, Erode, Tamil Nadu, India

E-mail: eceramya25@gmail.com, parthivelusamay@gmail.com, yogadeepan@gmail.com

(Received 8 December 2014; Revised 28 January 2015; Accepted 20 February 2015; Available online 27 February 2015)

Abstract - Recently, a new wireless technology, i.e., Worldwide interoperability for Microwave Access (WiMAX), has been demonstrated to have its strong potential to provide a very high speed of broadband services. By simultaneously using multiple antennas at transmitter and receiver sites, these systems exploit the spatial dimension of the propagation channel. The development of such antennas includes the design of array antenna, optimizing the array antenna parameters and thereby increasing its performance. This paper mainly focuses on design of single microstrip patch antennae and linear array configurations by optimizing the various antenna parameters such as directivity, gain, Mutual coupling and beamwidth etc., Microstrip array antennae designed and simulated using IE3D for WiMAX application operating at 2.4GHz and the same configurations are also optimized and analyzed. In this analysis, upon comparing the parameters such as gain, directivity, return loss and 3-dB beamwidth quantitatively it is proposed that the linear array promises very narrow beamwidth with optimized gain.

Keywords: Antenna Array, Directivity, Microstrip, Radiation Pattern, and WiMAX.

I. INTRODUCTION

The wireless communication technology is developing rapidly, so the wireless local area network (Wireless LAN) or the wireless personal area network (Wireless PAN) has been widely used in the office or home. In order to use the wireless networks in the cities and to build the backbone network appliance between the city and the country with a lower cost, a WiMAX (Worldwide Interoperability for Microwave Access) protocol of IEEE 802.16x have been introduced.

WiMAX, (Worldwide Interoperability for Microwave Access), is a telecommunications technology that provides wireless transmission of data using a variety of transmission modes, from point-to-multipoint links to portable and fully mobile internet access with the help of MIMO technology. MIMO stands for Multiple Input and Multiple Output and refers to the technology where there are multiple antennas at the base station and multiple antennas at the mobile device.

The layout of the access points in the backbone network is usually built in a long distance and peer-to-peer manner. Thus, the high directional antenna plays an important role therein so as to enhance the EIRP (Effective Isotropically Radiated Power) and to achieve the object of implementing the long distance transmission with a lower power. One of the ways to increase directivity and thus gain is to use array antennas [8].

The paper is organized as follows: Section II presents the topics related to the microstrip antenna. Section III describes the design procedure for the rectangular patch antenna and Section IV describes the simulation results and discussion. Section V concludes the paper with future recommendations.

II. MICROSTRIP PATCH ANTENNA

Microstrip antenna patch elements are the most common form of printed antennas. They are popular for their low profile, geometry and low cost. A microstrip device in its simplest form is a layered structure with two parallel conductors separated by a thin dielectric substrate. The lower conductor acts as a ground plane [2].

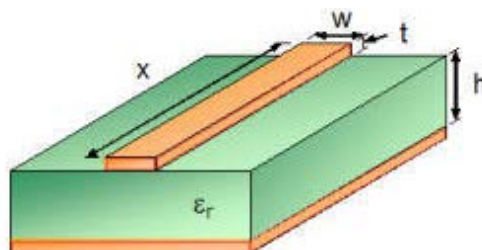

Fig. 1 Geometry for Analyzing the Edge-Fed Microstrip Patch Antenna

The device becomes a radiating microstrip antenna when the upper conductor is a patch with a length that is an appreciable fraction of a wavelength, approximately half a

wavelength. Conventional patch designs yield bandwidths as low as a few percent, as like figures 1 and 2.

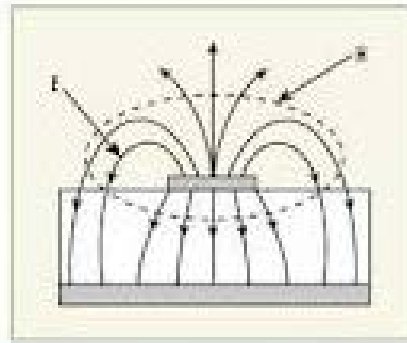

Fig. 2 Side View Showing the Electric Fields

A small bandwidth is the main drawback of the microstrip antennas. Some approaches have been developed for bandwidth enhancement. One way to increase the bandwidth is to either increase the height of the dielectric or decrease the dielectric constant.

Microstrip antennas have several advantages over the conventional microwave antennas, and therefore many applications cover the broad frequency range 100 MHz to 100 GHz. Lower gain and lower power handling limitations can be overcome through an array configuration. Among the different patch shapes rectangular patch is used widely because of its simple design considerations and analysis [5].

III. DESIGN OF MICROSTRIP RECTANGULAR PATCH

The most commonly employed microstrip antenna is a rectangular patch. The rectangular patch antenna is approximately a one-half wavelength long section of rectangular microstrip transmission line. When air is the antenna substrate, the length of the rectangular microstrip antenna is approximately one-half of a free-space wavelength. As the antenna is loaded with a dielectric as its substrate, the length of the antenna decreases as the relative dielectric constant of the substrate increases [1].

The design formulas were used to design a rectangular microstrip patch antenna and Table 1 has been formed. The patch was designed and optimized using IE3D for 2.4GHz which can be applicable for WiMAX application [4].

TABLE I DIMENSIONS OF PATCH ANTENNA PARAMETERS

Substrate Thickness	59.055181 mils	Dielectric Constant	4.6
Patch Length, L	1135.3216 mils	Patch Width, W	1470.50764 mils
Inset Width, S	112.640866 mils	Inset Depth, D	339.346 mils
Strip Width, T	56.3204331 mils	Feed Line Length, F	847.894606 mils

IV. RESULTS AND DISCUSSION

A. EM Optimization

EM optimization is one of the most important features of IE3D [9]. It can help designers to achieve their goal with much less effort. Some goal may even be impossible by manual tuning. EM optimization may yield excellent results for you. However, please understand the following fact: EM optimization is not supposed to replace designers. Users

should know what they want to do and what they can do before they jump into optimization. If you throw a garbage design into an EM optimizer, it will throw a garbage design back to you.

B. Simulation Tool

Electromagnetic Simulation is an Advanced Technology to yield high accuracy analysis and design of complicated Microwave and RF Printed Circuit Antennas, High-Speed

Digital Circuits and other electronic components. IE3D is an "Integrated full-wave Electromagnetic Simulation and Optimization" package for the analysis and design of 3D and planar microwave circuits, MMIC, RFIC, RFID, antennas, digital circuits and high-speed printed circuit

boards (PCB). IE3D is a full-wave Electromagnetic solver. It solves the Maxwell Equations, which govern the macro electromagnetic phenomenon. There is no much assumption involved except the numerical nature of the method. Therefore, the solution is extremely accurate [9].

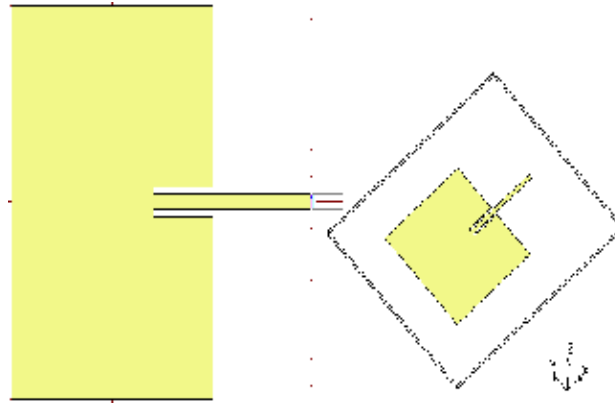

Fig. 3 The illustration of a simple edge-fed patch antenna

For this antenna, we can adjust the length L to change the resonant frequency and the inset depth D to tune the matching. Also, both variables are not independent or changing L may change the matching and changing D may change the resonance. If they are independent, we can optimize one dimension at a time and it may make an optimization much easier. Assume we want to optimize this antenna to a perfect match at 2.4 GHz. Our goals are: $\text{Re}[S(1,1)] = 0$ and $\text{Im}[S(1,1)] = 0$ at 2.4 GHz.

On MGRID, structures are not described as parameterized objects. All structures are described by polygons and polygons are described by vertices. To change the shape of a structure, we need to change the locations of vertices. We need to identify which vertices we should adjust to change the L and D values. IE3D LIBRARY has

complete parameterized structure objects with equation-based dimensions. It is extremely flexible in optimizing structures.

C. Optimization of Single Patch

The figures 4 and 5 shows the change in feed patch of the single rectangular patch after optimization. Dielectric substrate glass epoxy (FR4) is used here. Glass epoxy chosen because, it has $\epsilon_r = 4.6$ and $\tan \delta = 0.001$ which is very small compared to other dielectrics. The loss tangent is a metric of the quantity of the electrical energy which is converted to heat by a dielectric. The lowest possible loss tangent maximizes the antenna efficiency. If the dielectric constant ϵ_r is larger, the smaller element size to be achieved [6].

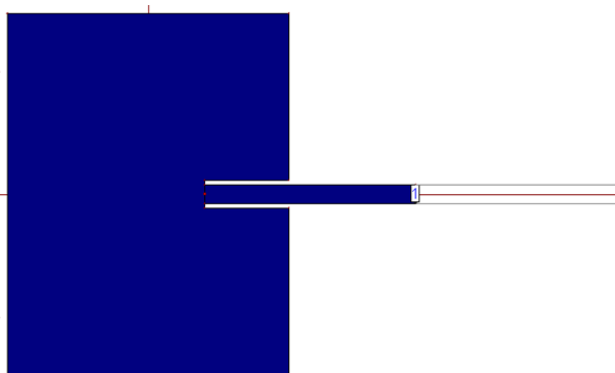

Fig. 4 Single patch without optimization

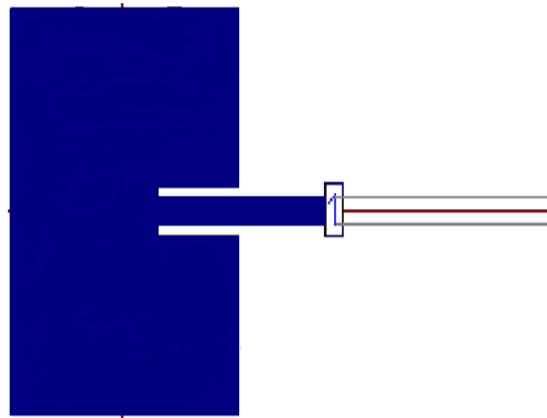

Fig. 5 Single patch with optimization

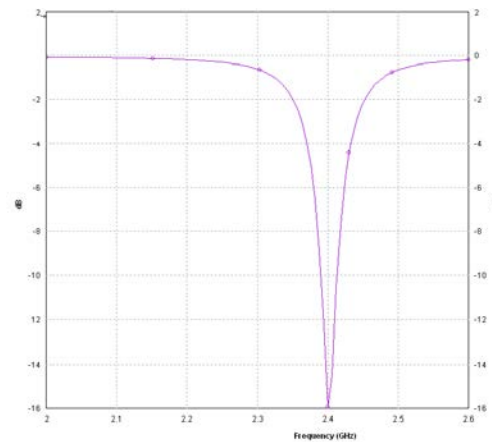

Fig. 6 Plot of Reflection Coefficient without optimization

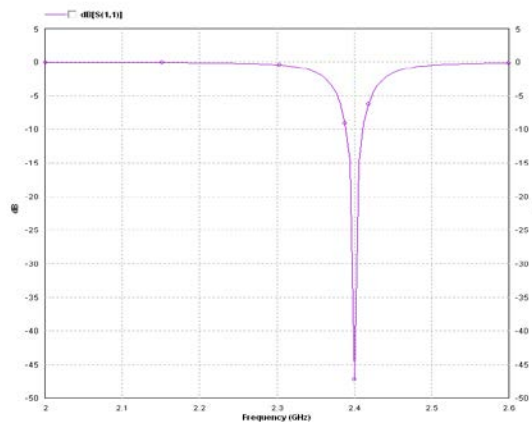

Fig. 7 Plot of Reflection Coefficient of Single Patch with optimization

From the fig.6.1.1 we can see that reflection coefficient value of -47dB has been achieved at 2.4 GHz which can be used for WiMAX applications.

The variable chosen here for optimization are length of the patch and the depth of the inset feed given to the patch. The corresponding vertices are selected and declared as variables for optimization in 'Optimization variable definition dialog'. The value of length is varied from -

100mils to 100mils from its default value. The value of inset depth is varied from -150mils to 150mils from its default value.

The optimization set up is simulated for the resonant frequency 2.4GHz with optimization goals as real and imaginary part of s-parameter.

V. ARRAY CONFIGURATIONS

There are different types of array configurations available namely linear, planar, circular, concentric circular and cylindrical array. In linear array there are N elements which are placed along a line. It is the simplest one among different array configurations. In planar array, individual elements are positioned along a rectangular grid to form a rectangular or planar array. They are more versatile and provide more symmetrical patterns with lower side lobes. Applications include tracking radar, search radar, remote

sensing, etc. In circular array, the elements are placed in a circular ring [5,6]. It is an array configuration of very practical interest. Its applications spans radio detection finding, air and space navigation, underground propagation, radar, sonar and many other systems. In concentric circular configuration [6,7], the elements are placed in circular ring with increasing radius. In cylindrical array, the circular array is stacked one above other to form cylindrical configuration.

A. Linear Array Configuration and its Simulations Using IE3D

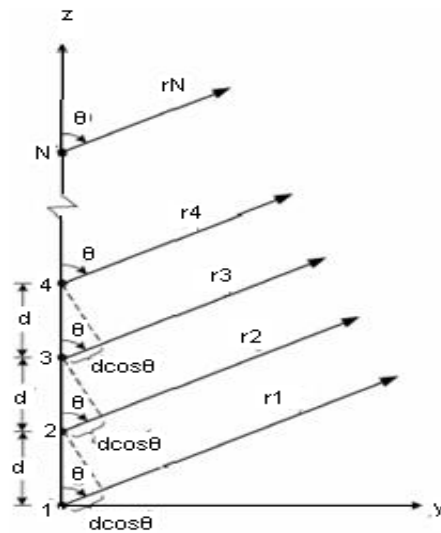

Fig. 8 Linear array

The linear array includes N-elements arranged in z-direction. Assuming that all elements have identical amplitudes but each succeeding element has a β progressive phase lead current excitation relative to the preceding one. An array of identical elements all of identical magnitude and each with a progressive phase are referred to as a uniform array [2]. The array factor is given by

$$AF = \sum_{n=1}^N e^{+j(n-1)(k d \cos\theta + \beta)} \quad (1)$$

This can be written as

$$AF = \sum_{n=1}^N e^{+j(n-1)\Psi} \quad (2)$$

Where $\Psi = k d \cos\theta + \beta$

The maximum radiation occurs at

$\psi = 0$ hence $\beta = -k d \cos\theta$

An eight element linear array having infinite ground plane with individual feed is designed using the optimized single patch and simulated using IE3D. The space between the elements is kept as 0.7λ to reduce the mutual coupling between array elements [3].

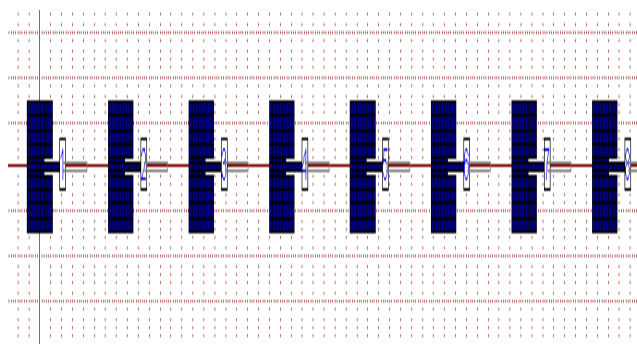

Fig. 9 Linear array with infinite ground plane and individual feed

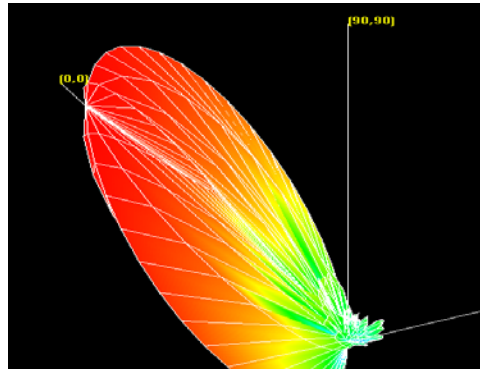

Fig.10 3D Radiation pattern of 8-element linear array

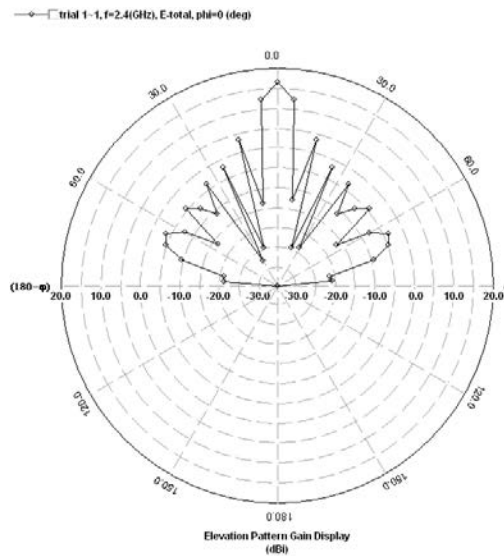

Fig. 11 2D Radiation pattern of 8-element linear array

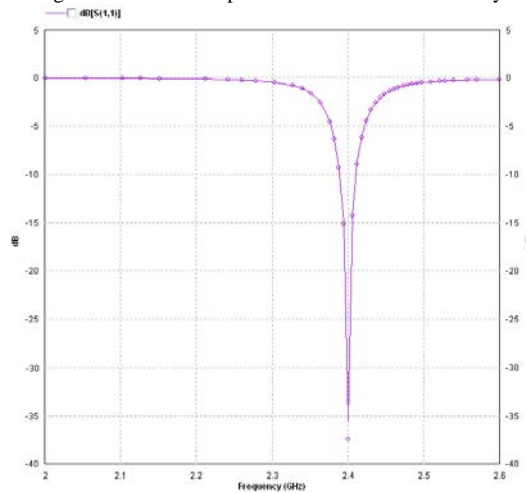

Fig. 12 S-Parameter vs. Frequency plot for 8-element linear array

Figure 10 and 11 shows the radiation pattern of 8-element linear array in 3- and 2-Dimensional view respectively. It is observed that the pattern consists of narrow beam main width and 7 number of side lobes, which will reduce the directivity. From figure 12, the reflection

coefficient value of -35dB has been achieved at 2.4 GHz which can be used for Wi-MAX applications. As shown in figure 13, the maximum gain is obtained in the broadside direction for linear array is 17dBi at the frequency of 2.4GHz.

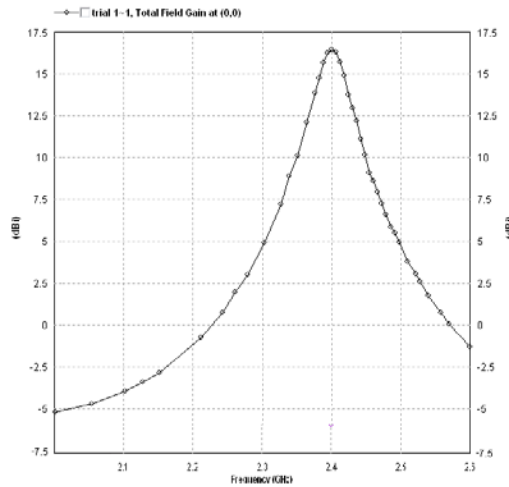

Fig. 13 Total field gain vs. Frequency plot for 8-element linear array

VI. CONCLUSION

The optimized single patch has required return loss for the WiMAX application but has poor directivity and gain. The linear microstrip array configurations discussed found to have the necessary gain and directivity along with optimum return loss for WiMAX application. The individually fed linear array with 8 elements has appreciable gain and directivity but has N-1 side lobes. The linear 8-element array with corporate feed (single feed) is economical when compared with individually fed array in case excitation sources. The linear 8-element array with corporate feed on a finite ground plane is more practical in case of real time implementation. The gain is comparable with previous case. From the simulation results it is found that 8-element linear array has an optimum directivity and beamwidth which can be used for WiMAX.

REFERENCES

[1] Alka verma, Neelam shrivastava., O. 'Analysis and design of Rectangular Microstrip Antenna in X Band' MIT International Journal of ECE Vol.1, NO.1, pp. 31-35, (2011).

[2] Constantine A.Balanis, 'ANTENNA THEORY - Analysis and Design', Second Edition: Reprinted, John Wiley Publications, (2007).
 [3] Gunasekaran, T. and Shankar Kumar, K.R. "Evaluation of MIMO System Capacity with Spatial Correlations", Journal of Computer Science, Vol. 7, No. 10, pp. 1490-1496, (2011).
 [4] K.R.Kashwan, V.Rajeshkumar, T Gunasekaran, K.R. Shankar kumar, "Design and Characterization of pin fed Microstrip Patch Antennae", Proceedings of FSKD 2011, IEEE XPLORE, pp. 2258-2262, (2011).
 [5] L. Bogdan, and C. Comsa., 'Analysis of circular arrays as smart antennas for cellular networks', Proc. IEEE Int. Symp. Signals,Circuits and Systems'03, Vol.2, pp. 525,528, (2005).
 [6] M. Dessouky H. Sharshar, and Y.Albagory 'Efficient Side lobe Reduction Technique For Small-Sized Concentric Circular Arrays', Department of Electronics and Electrical Communications Engineering, Faculty of Electronic Engineering, Menouf, Egypt, Progress In Electromagnetics Research, PIER 65, pp. 187-200, (2006).
 [7] Panayiotis Ioannides and Constantine Balanis,A. "Uniform Circular and Rectangular Arrays for Adaptive Beamforming Applications", IEEE Antennas and Wireless Propagation Letters, Vol. 4, pp.351-354, (2005).
 [8] Weiwei Wu, Jiaxian Yin and Naichang Yuan "Design of an Efficient X-band Waveguide-fed Microstrip Patch Array", IEEE Transactions on Antennas and Propagation, Vol. 55, No. 7, pp. 1933-1939, (2007).
 [9] IE3D User's Manual, Release 9, Zeland Software, Inc.