

Medical Image Fusion Schemes Using Contourlet Transform and PCA Bases

R.Nithya¹ and S.Elayaraja²

¹M.E., Applied Electronics, Department of ECE, Muthayammal Engineering College, Rasipuram, Tamil Nadu, India ²Asst. Professor, Department of Civil Engineering, KPR Institute of Engineering and Technology, Coimbatore, Tamil Nadu, India

E-mail: nithyaramuthu@gmail.com, elayaraja86@gmail.com

(Received 25 February 2015; Revised 10 March 2015; Accepted 31 March 2015; Available online 8 April 2015)

Abstract - Fusion imaging is one of the most modern, accurate and useful diagnostic techniques in medical imaging today. The new technology has made a clear difference in patient care by compressing the time between diagnosis and treatment. Although image fusion can have different purposes, the main aim of fusion is spatial resolution enhancement or image sharpening. Also known as integrated imaging, it provides a computer link that allows for the combination of multimodal medical images into a single image with more complete and accurate description of the same object. The benefits are even more profound in combining anatomical imaging modalities with functional ones. For example, PET-CT in lung cancer, MRI-PET in brain tumors, SPECT-CT in abdominal studies and ultrasound images-MRI for vascular blood flow . outcome of MRI-CT image fusion has been shown to be able to assist in planning surgical procedure. Mainly, medical image fusion try to solve the issue of where there is no single modality provides both anatomical and functional information. Further more information provided by different modalities may be in agreement or in complementary nature.

I.INTRODUCTION

Medical image fusion has been used to derive useful information from multimodality medical image data. This paper presents a dual-tree complex contourlet transform (DTCCT) based approach for the fusion of magnetic resonance image (MRI) and computed tomography (CT) images. The objective of the fusion of an MRI image and a CT image of the same organ is to obtain a single image containing as much information as possible about that organ for diagnosis. The limitation of directional information of dual-tree complex wavelet (DT-CWT) is rectified in DT-CCT by incorporating directional filter banks (DFB) into the DT-CWT. To improve the fused image quality, new methods for fusion rules which depend on frequency component of DT-CCT coefficients (contourlet domain) have been presented .For low frequency coefficients PCA and local energy weighted selection are incorporated as the fusion rules in a contourlet domain and for high frequency coefficients, the salient features are picked up based on local energy. The final fusion image is obtained by directly

applying inverse dual tree complex contourlet transform (IDT-CCCT) to the fused low and high frequency coefficients. As the clinical is used of different medical imaging systems extends, the multimodality imaging acting an increasingly important part in a medical imaging field. Different medical imaging techniques may provide scans with complementary and occasionally unnecessary information. The combination of medical images can often lead to additional clinical information not noticeable in the separate images. MRI-CT image fusion presents an accurate tool for planning the correct surgical procedure and is a benefit for the operational results in computer assisted navigated neurosurgery of temporal bone tumors .

A.Overview of Image Fusion

The goal of image fusion is to integrate complementary information from multimodality images so that the new images are more suitable for the purpose of human visual perception and computer processing. Therefore, the task of image fusion is to make many salient features in the new image such as regions and their boundaries. Image fusion consists of putting together information coming from different modality of medical images, whereas registration consists of computing the geometrical transformation between two data sets. This geometrical transformation is used to resample one image data set to match other. An excellent registration is set for an excellent fusion. The process of information fusion can be seen as an information transfer problem in which two or more information sets are combined into a new one that should contain all the information from the original sets. During the process of fusion, input images A and B are combined into a new fused image F by transferring, ideally all of their information into F . This is illustrated graphically using a simple Venn diagram.

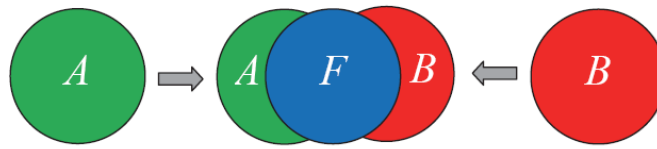

Fig. 1 Graphical representation of the image information fusion process.

Medical image fusion usually employs the pixel level fusion techniques. The purpose of pixel-level image fusion is to represent the visual information present in input images, in a single fused image without the introduction of distortion or loss of information. The advantage of pixel level fusion is that the images used the contained the original information. Furthermore, the algorithms are rather easy to implement and time efficient. The classification of pixel-to-pixel based image fusion methods is illustrated in Figure 1. The aim of this classification was to identify, with different degrees of detail, complexity and accuracy. The main component is the domain of implemented the image fusion which however are not always strictly separable (Chen and Li, 2005). Many algorithms developed so far can be classified into four primary categories:

1. Substitution methods such as principal component analysis (PCA) averaging weighted, color mixed RGB and intensity hue saturation(IHS).
2. Mathematical combination which normalizes multispectral bands used for an RGB display such as Brovey Transform.
3. Optimization approach such as Bayesian and neural network
4. Transform domain such as multiresolution decomposition which introduces spatial features from the high-resolution images into the multispectral images. contourlet transform and Nonsubsampled contourlet transform.

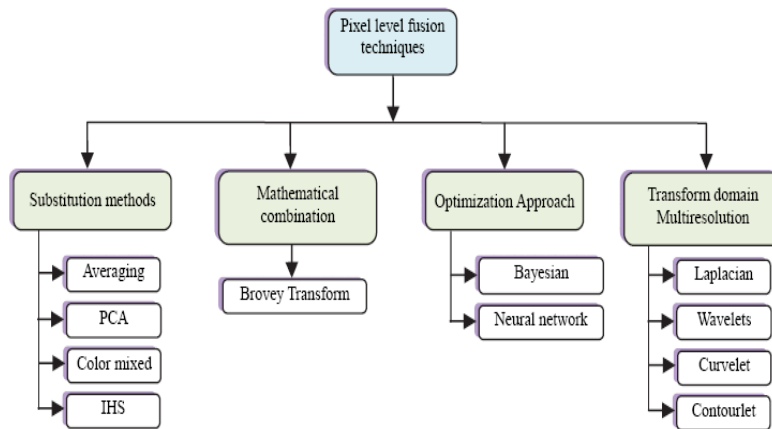

Fig.2 The classification of pixel-to-pixel based image fusion methods.

II. DUAL TREE COMPLEX CONTOURLET TRANSFORM

A complex contourlet transform (CCT) method is proposed by which incorporates the DT-CWT and DFB to provide a flexible and robust scale direction representation for source images. The DT-CWT decomposition details space WJ at the J -th scale, gives six subbands at each scale capturing distinct directions. Traditionally, we obtain the three highpass bands corresponding to the LH, HL, and HH

subbands, indexed by $i \in \{1, 2, 3\}$. Each of them has two wavelets as real and complex part. By averaging the outputs of dual tree, we get an approximate of shift invariant. In second stage for each subband applied (lJ) levels DFB as shown in Figure 2. WJ of DT-CWT is nearly shift invariant and this property can be still established in the subspace $W_{J,k}^{(lJ)}$, even after applying directional filter banks on a detail subspace WJ . The mathematical form is defined as:

$$\eta_{J,k,n}^{i,(lJ)} = \sum_{m \in \mathbb{Z}^2} g_k^{lJ} [m - S_k^{(lJ)}n] \psi_{J,m}^i \quad i = 1, 2, 3$$

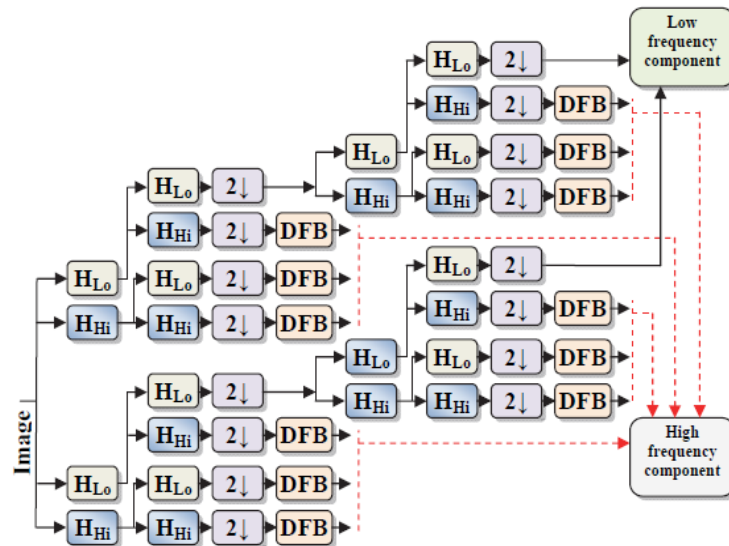

Fig. 3. The proposed of DT-CCT based on Fusion Rules.

III. REQUIREMENTS AND CHALLENGES OF IMAGE FUSION

The reason of image fusion is to integrate complementary and redundant information from multiple images to produce a combined that contains a superior description of the scene than any of the individual source images. Considering the objectives of image fusion and its potential advantages, some generic requirements can be imposed on the fusion algorithm.

- a) It should not discard any salient information contained in any of the input images.
- b) It should not introduce any artifacts which can distract or mislead a human observer or any subsequent image processing steps.
- c) It must be reliable, robust and, as much as possible, tolerant of imperfections such as noise or misregistrations.

However, a fusion approach which is independent of the modalities of the inputs and produces a combined image which appears accepted to a human interpreter is highly wanted.

A. Image fusion approach (DT-CCT-PCA and DT-CCT-PCA/LE)

The proposed image fusion approach consists of the following steps:

Step 1. Perform a DT-CCT on source images A and B, respectively, and obtain the

Corresponding coefficients $\{Coff^{(L,A)}, Coff^{(H,A)}_{j,l}\}$ and $\{Coff^{(L,B)}, Coff^{(H,B)}_{j,l}\}$ where $Coff(L,A)$ and $Coff(L,B)$ represent low frequency coefficients of image A and B respectively at the coarsest scale .

Step 2. Employ some fusion rules to reconstruct the DT-CCT coefficients of the fused image F as shown

$$\{Coff^{(L,F)}, Coff^{(H,F)}_{j,l}\}.$$

Step 3. By successively performing inverse dual tree complex contourlet transform to the modified coefficients at all decomposition, the final fused image F can be reconstructed.

1. Fusion rules for low frequency coefficients

The following are the methods proposed for fusion rules:

Method 1: Complex contourlet transform based on maximum selection (CCT-Max) As the coefficients in the coarsest scale subband $\{Coff^{(L,A \text{ or } B)}_0\}$ represents the approximation component of the source image, the simplest way is to use the conventional maximum selection method to produce the composite coefficients. The maximum selection method is a popular choice to pick out the salient features of an image, e.g. edges and boundaries.

The normalized weight $D^{(L,A)} \in \{0,1\}$ is defined as:

$$D^{(L,A)} = \begin{cases} 1 & |Coff^{(L,A)}_0| \geq |Coff^{(L,B)}_0| \\ 0 & \text{otherwise} \end{cases}$$

Method 2: Dual tree complex contourlet transform based on PCA (DT-CCT-PCA)

The principal component analysis PCA can be used as a weighted precision measure to determine which pixel or region is important for fused. Dual tree complex contourlet transform based on PCA is implemented as described in. PCA is also called the Karhunen-Loève transform or the

Hotelling transform. It involves a mathematical procedure that transforms a number of correlated variables into a number of uncorrelated variables called principal components. It is also used to reduce dimensionality in a dataset while retaining those characteristics of the dataset that contribute most to its variance. It computes a compact and optimal description of the data set. PCA has been employed in some fusion rules. The fusion rule for low frequency component in contourlet domain is implemented as:

$$D^{(L,A)} = \frac{i}{i+j} \quad \text{and} \quad D^{(L,B)} = \frac{j}{i+j}$$

where i and j are the elements of the principal eigenvector, which are computed by analyzing the original input image A and B for corresponding image coefficients.

Method 3: Dual tree complex contourlet transform based on PCA and Local energy (DTCCT-PCA/LE). In this method, PCA and local energy weighted selection are incorporated as the fusion rules in contourlet domain. First, calculate the local energy $E^{(A \text{ or } B)}_{Low}(x, y)$ of low frequency component in contourlet domain centering at the current coefficient $\text{Coeff}_{j_0}^{(L,A \text{ or } B)}$ which is defined as:

$$E^{(A \text{ or } B)}_{Low}(x, y)_{j_0} = \sum_m \sum_n \text{Coeff}_{j_0}^{(L,A \text{ or } B)}(x+m, y+n)^2 \cdot W(m, n)$$

where W is a template of size 3×3 and satisfy the normalization rule.

$$W = \frac{1}{9} \begin{bmatrix} 1 & 1 & 1 \\ 1 & 1 & 1 \\ 1 & 1 & 1 \end{bmatrix} \quad \text{and} \quad \sum_m \sum_n W(m, n) = 1$$

The normalized weight $D^{(L,A \text{ or } B)} \in \{0, 1\}$ is defined as:

$$\left. \begin{cases} D^{(L,A)} = \begin{cases} 1 & |E^{(A)}_{Low}(x, y)_{j_0}| \geq |E^{(B)}_{Low}(x, y)_{j_0}| \\ 0 & \text{otherwise} \end{cases} \\ D^{(L,B)} = 1 - D^{(L,A)} \end{cases} \right\} \text{for } E^{(A \text{ or } B)}_{Low}(x, y)_{j_0} \geq \delta$$

$$\left. \begin{cases} D^{(L,A)} = i / (i+j) \\ D^{(L,B)} = j / (i+j) \end{cases} \right\} \text{for } E^{(A \text{ or } B)}_{Low}(x, y)_{j_0} < \delta$$

IV. OBJECTIVE EVALUATION OF IMAGE FUSION

Objective evaluations of fused images are important in comparing the performance of different image fusion algorithms. Objective evaluation methods are needed to compare good or bad fused images. Many image quality evaluations in the literature use an ideal fused image as a reference for comparison with the image fusion proposed metrics based on mutual information for image sequence and still image fusion performance. The root mean squared error and peak signal to noise ratio-based metrics were

widely used for these comparisons. The gradient representation metric is based on the idea of measuring localized preservation of input gradient information in the fused image. An image quality index based on the structural metric proposed by was improved for image fusion assessment by into a pixel by pixel or region by region method, giving weighted averages of the similarities between the fused image and each of the source images.

Image Quality Index (IQI), is easy to calculate and applicable to various image processing application. The dynamic range of IQI is $[-1, 1]$. The best value 1 is achieved if and only if $F = R$, where F is fused image and R is reference image. IQI is defined as:

$$IQI = \frac{\sigma_{FR}}{\sigma_F \sigma_R} \cdot \frac{2\overline{FR}}{(\overline{F})^2 + (\overline{R})^2} \cdot \frac{2\sigma_F \sigma_R}{\sigma_F^2 + \sigma_R^2}$$

Where,

$$\overline{g} = \frac{1}{Z} \sum_{i=1}^Z g_i, \quad \sigma_{FR} = \frac{1}{Z-1} \sum_{i=1}^Z (F_i - \overline{F})(R_i - \overline{R}) \quad \text{and} \quad \sigma_g^2 = \frac{1}{Z-1} \sum_{i=1}^Z (g_i - \overline{g})^2,$$

$g = F$ or R and $Z = N \cdot M$ (size of the image).

Coefficient Correlation (CC), can show similarity in the small structures between the original and reconstructed images. Higher value of correlation means that more information is preserved. Coefficient correlation in the space domain is defined by:

$d =$ image A or image B .

$$CC(F, d) = \frac{\sum_{i=0}^{M-1} \sum_{j=0}^{N-1} (F(i, j) - \overline{F})(d(i, j) - \overline{d})}{\sqrt{\sum_{i=0}^{M-1} \sum_{j=0}^{N-1} (F(i, j) - \overline{F})^2 \sum_{i=0}^{M-1} \sum_{j=0}^{N-1} (d(i, j) - \overline{d})^2}}$$

where F and d are the mean value of the corresponding data set.

Overall Cross Entropy (OCE), is used to measure the difference between the two source images and the fused image. Small value corresponds to good fusion result obtained. The OCE calculation is as follows:

$$OCE(A, B; F) = \frac{CE(A, F) + CE(B, F)}{2}$$

where $CE(A, F)$ and $CE(B, F)$ are the cross entropy of the source image.

Root Mean Square Error (RMSE), is found between the reference image R and the fused image F , defined as:

$$RMSE = \left(\frac{1}{c} \right) \sum_k \sqrt{\frac{\sum_{x=1}^N \sum_{y=1}^M (R_k(x, y) - F_k(x, y))^2}{M \times N}}$$

where $c=3$ and $k=R, G, B$ for color image and $c=1$ for gray image. The smaller the value of the RMSE means a better performance of the fusion algorithm.

V. EXPERIMENTAL RESULTS FOR IMAGE FUSION

In this section, we present some experimental results obtained with presented fusion methods.

A. Robust image fusion using Dual Tree Complex Contourlet transform (DT-CCTPCA and DT-CCT-PCA/LE)

To test proposed method, thirty five groups of human brain images were selected, includes a CT and a MRI images. The corresponding pixels of two input images have been perfectly co-aligned. All images have the same size of 512×512 pixels, with 256-level grayscale. The proposed medical fusion algorithm, traditional complex contourlet

and DT-CWT are applied to these image sets. In our experiment an image is decomposed into 2-levels using biorthogonal Daubechies 9-7 wavelet Each subband at each level is fed to the DFB stage with 8-directions at the finest level. In the DFB stage, the 23-45 biorthogonal quincunx filters were used designed and modulate them to obtain the biorthogonal fan filters. DT-CWT is available in Matlab wavelet software .In addition, image quality index (IQI), root mean square error (RMSE), correlation coefficient (CC) and overall cross entropy (OCE) are used to evaluate the fusion performance (objective evaluation). Experiment results were conducted to compare the proposed methods DT-CCT-PCA and DT-CCT-PCA/LE with complex contourlet transform based on maximum amplitudes (CCT-max) and dual tree complex wavelet transform (DT-DWT).

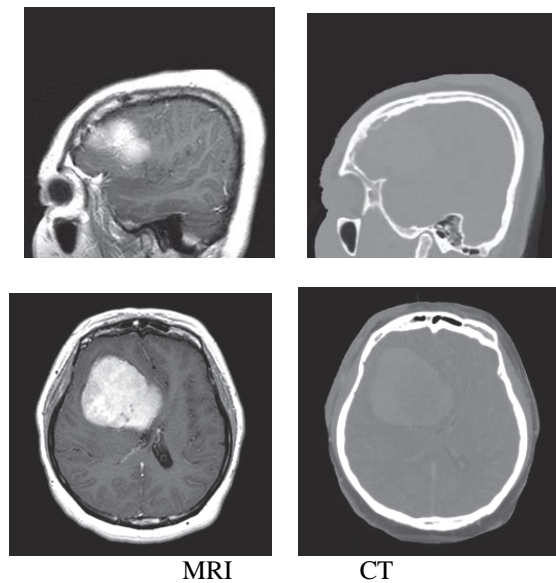

Fig.4.Original multimodality image dataset 1 and 2.

The evaluation results in Table 1 and the complete data sets show that:

1. From indicators, the IQI and CC are the best with the proposed methods, higher value of correlation or IQI, means that more information is preserved. The OCE and RMSE of the new methods are least in the two sets. It is shown that, the proposed method gives the best fusion results in the two fused images.
2. For the two image sets, the corresponding fused image results are given in Figure6.1 DTCCT-PCA performs better than previous method. However, the best image fusion result is obtained by applying the proposed DT-CCT-PCA/LE fusion algorithm.
3. It is evident to see from the Table 1 and the complete data sets that the resulting image from DT-CCT-PCA/LE based fusion has better spectral quality than the other methods, in terms of the
4. Fusion scheme based the novel weighted PCA/LE rule can get better fusion image. As shown in Table 1 and the complete data sets, for DT-CCT-PCA/LE the RMSE and OCE are both lower than that of traditional based methods, lowest values of RMSE and OCE are 0.1017, 0.4527 respectively. The lowest values of RMSE and OCE are 0.1683, 0.8726 respectively for CCT-max.

- Experimental results demonstrate that the proposed method DT-CCT-PCA/LE Out performs the DT-CCT-PCA-based fusion approach and the

traditional CCT-maxbased approaches and including the DT-CWT-based in terms of both visual quality and objective evaluation.

TABLE I.RESULTS OF QUALITY MEASURES FOR VARIOUS FUSION SCHEMES.

Data	Evaluation	DT-CWT	CCT-max	DT-CCT-PCA	DT-CCT-PCA/LE
Data set 1	IQI	0.2581	0.2513	0.3236	0.4250
	RMSE	0.1683	0.1683	0.1442	0.1017
	CC	0.9482	0.9482	0.9523	0.9641
	OCE	0.8726	0.8726	0.8683	0.8531
Data set 2	IQI	0.3340	0.3523	0.4171	0.3843
	RMSE	0.2179	0.2180	0.1480	0.2281
	CC	0.9750	0.9750	0.9853	0.9929
	OCE	1.0865	1.0863	0.9911	0.4527

VI. CONCLUSION

A new approach for multimodal image fusion using dual-tree complex contourlet transform (DT-CCT) based on PCA and combined (PCA and local energy) are proposed. The method is based on PCA, local energy and dual tree complex contourlet transform. The image contents like

tissues are clearly enhanced. Other useful information like brain boundaries and shape are almost perfectly. The dual tree complex contourlet transform produces images with improved contours and textures, while the property of shift invariance is retained. It enhances the reliability of conventional approaches considerably and thereby their acceptability by practitioners in a clinical environment.

DT-DWT

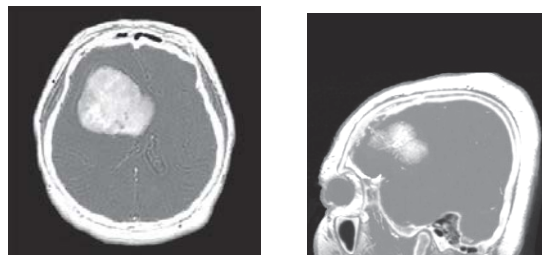

CCT-max

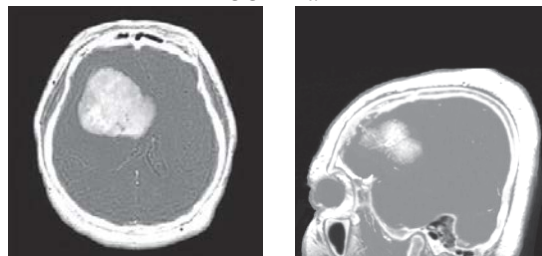

DT-CCT-PCA

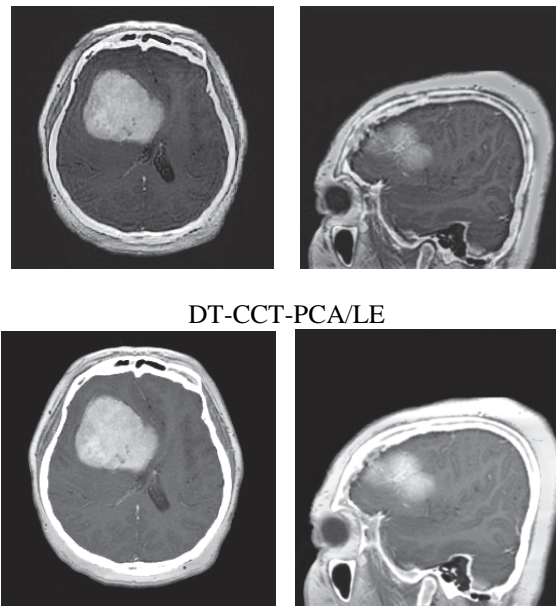

Fig.5. Fusion results on test original multimodality image dataset 1 and 2 using DT-CWT,traditional CCT-max and proposed methods.

The methods present a new development in the fusion of MRI and CT images, which is based on the DT-CCT. Visual and objective evaluation comparisons demonstrated that the fusion results (Figure 6.1) of the new method contain more detail information, while information distortion is very small. It enhances the reliability of conventional approaches considerably and thereby their acceptability by practitioners in a clinical environment.

REFERENCES

- [1] Aguilar, M. & New, J. R. (2002). Fusion of multi-modality volumetric medical imagery, *In Proceedings of the Fifth International Conference on Information Fusion*, 2, pp. 1206-1212, ISBN0-9721844-1-4,annapolis, MD, 2002.
- [2] Al-Azzawi, N., Sakim, H. A. M., Abdullah, W. A. K. W. & Ibrahim, H. (2009). Medical imagefusion scheme using complex contourlet transform based on PCA, *AnnualInternational Conference of the IEEE Engineering in Medicine and Biology Society, EMBC2009*, pp. 5813-5816, ISBN 1557-170X, Hilton Minneapolis, Minnesota, USA, 2-6 September, 2009.
- [3] Bamberger, R. H. & Smith, M. J. T. (1992). A filter bank for the directional decomposition of images: Theory and design. *IEEE Transactions on Signal Processing*, Vol. 40, No.4, pp.882-893, ISSN 1053587X.
- [4] Baum, K., Helguera, M. & Krol, A. (2008). Fusion viewer: A new tool for fusion and visualization of multimodal medical data sets. *Journal of Digital Imaging*, Vol. 21, pp.59-68, ISSN 0897-1889.
- [5] Roche, A., Malandain, G., Pennec, X. & Ayache, N. (1998). The correlation ratio as a new similarity measure for multimodal image registration. *In: WELLS, W.M. Medical Image Computing and Computer-Assisted Intervention - MICCAI'98*. Springer Berlin Heidelberg, 1496, pp. 1115-1124, ISBN978-3-540-65136-9.
- [6] Ruiz, V. G., Fernández, J. J., López, M. F. & García, I. (2002). Progressive image transmission in telemicroscopy: A quantitative approach for electron microscopy images of biological specimens. *Real-Time Imaging*, Vol. 8, No.6, pp. 519-544, ISSN 1077-2014.
- [7] Yang, L., Guo, B. L. & Ni, W. (2008). Multimodality medical image fusion based on multiscale geometric analysis of contourlet transform. *Neurocomputing*, Vol. 72, No.1-3, pp. 203-211, ISSN 0925-2312.
- [8] Yong, C., You, H. & Chaolong, Y. (2008). CT and MRI image fusion based on contourlet using a novel rule, *The 2nd International Conference on Bioinformatics and Biomedical Engineering, ICBBE 2008*, pp. 2064-2067, ISBN 978-1-4244-1747-6, Shanghai, 16-18 May, 2008.