

Implementation of a Novel DC-AC Single Phase Resonant Inverter Using Soft Switching Boost Converter

M.Rajeshwari, E.Mageswari and M.Yuvaleela

Department of Electrical & Electronics Engineering, Prathyusha institute of technology and management, Tamil Nadu, India

E-mail: rajeshwari.eee@prathyusha.edu.in, mageswari.eee@prathyusha.edu.in, Yuvaleela.eee@prathyusha.edu.in

(Received 4 July 2014; Revised 20 July 2014; Accepted 13 August 2014; Available online 20 August 2014)

Abstract - In this paper, a novel DC-AC single phase inverter is proposed. When the switches are turned on and off, a conventional inverter generates switching loss because of the hard switching. Thus the inverter losses increased. The proposed system contains an auxiliary circuit. The converter stage switches perform soft-switching because of the auxiliary circuit. Also inverter stage switches perform ZVS when the DC link voltage is zero. Therefore all the switching when the switches are turned on and off. Thus the proposed system reduces switching loss and voltage stress.

Keywords: H-Bridge Inverter, Soft Switching Boost Converter, Soft Switching Techniques.

I. INTRODUCTION

Nowadays, the power electronics are required to develop smaller, lighter, less expensive and reliable system. In order to operate these systems, a switching frequency has to be increased. But, increasing the inverter switching frequencies is dependent on the advances in device technology and makes higher switching losses.

To solve this problem, the soft switching techniques have been adopted in the inverter circuit. By the soft-switching techniques, the switching losses are ideally zero and the switching frequencies can be increased to above the audible range. In this paper, a novel DC-AC single phase resonant inverter using soft switching boost converter is proposed. This proposed inverter consists of soft-switching boost converter and H-bridge inverter. The soft-switching boost converter in proposed inverter additionally has resonant inductor L_r , resonant capacitor C_r , bridge diode and auxiliary switch Q_2 . When the resonance between resonant inductor and capacitor is generated, the converter switches are turned on and off with soft-switching. Also H-bridge inverter switches are turned on and off with ZVS when the auxiliary switch is turned off. So all of the switches are turned on and off with soft-switching.

Therefore the novel DC-AC single phase resonant inverter using soft-switching boost converter can reduce the switching loss and voltage stress. In this paper, we have analyzed the operational principle of the proposed resonant inverter. Simulation results presented to confirm the theoretical analysis

II. PROPOSED INVERTER

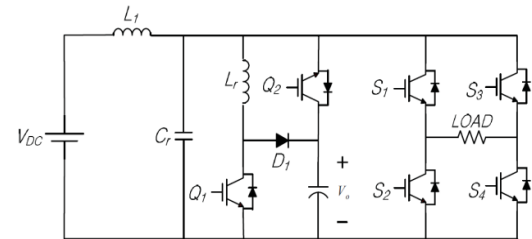

Fig. 1 Proposed novel DC-AC single phase resonant inverter using soft Switching boost converter

Fig. 1 shows the proposed a novel DC-AC single phase resonant inverter using soft-switching boost converter. The auxiliary circuit in proposed inverter consists of an auxiliary switch, resonant inductor, resonant capacitor, and bridge diode. So, the main switch is turned on with ZCS and turned off with ZVS. Also the auxiliary switch is turned on and off with ZVS. Therefore, the converter stage switches perform the soft-switching

The H-bridge inverter performs the soft-switching under the influence of the dc-link voltage. When the auxiliary switch is turned off with ZVS, the dc-link voltage is zero. The inverter switches are turned on and off with ZVS while the dc-link voltage becomes zero. So all of switches in proposed inverter are turned on and off with soft-switching.

Therefore, the proposed soft-switching inverter has many advantages like as improved efficiency, low switching losses, low voltage stress, reduced acoustic noise and EMI. Another significant advantage of the proposed topology is an excellent PWM capability due to not only variable link pulse but also variable pulse position.

The proposed inverter operation mode analysis can be divided into six modes, as shown in Fig 2. Fig 3 shows the proposed waveforms for the novel DC-AC single phase resonant inverter using soft-switching boost converter.

III. EQUIVALENT CIRCUIT ANALYSIS

A. Mode1 ($t_0 < t < t_1$)

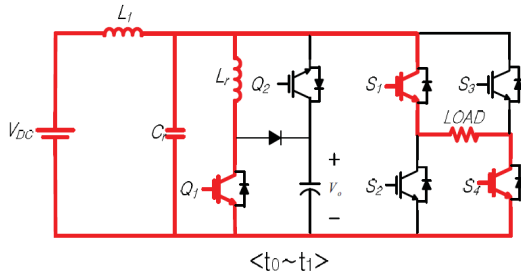

The resonant capacitor is discharged through resonant path Cr and Lr. The resonant inductor current begins to increase linearly from zero. Therefore, the main switch is turned on with ZCS influenced by resonant inductor. The energy of the main inductor is delivered to the load through the switches (S1, S4).

The next mode is started as soon as the resonant capacitor has fully discharged. In this mode, the main inductor current is given by

$$i_{L1}(t) = i_{L1}(t_0) + V_{in}/L(t_1 - t_0) \quad (1)$$

$$i_{L1}(t_0) \equiv I_{min} \equiv i_{Lr}(t_0) \quad (2)$$

Initial resonant inductor current and capacitor voltage given by

$$i_{Lr}(t_0) \equiv 0 \quad (3)$$

$$V_{cr}(t_0) \equiv V_{out} \quad (4)$$

The resonant period is

$$t_r = \pi / 2 \sqrt{L_r C_r} \quad (5)$$

The resonant impedance is

$$Z_r = \sqrt{L_r / C_r} \quad (6)$$

The inductor current and resonant capacitor voltage in resonant period are given by,

$$i_{Lr}(t) = (I_{L1min} - I_0) + I_0 \cos \omega_r (t_1 - t_0) \quad (7)$$

$$V_{cr}(t) = V_0 \cos \omega_r (t_1 - t_0) - V_0 / Z_r \cdot \sin \omega_r (t_1 - t_0) \quad (8)$$

B. Mode 2 ($t_1 < t < t_2$)

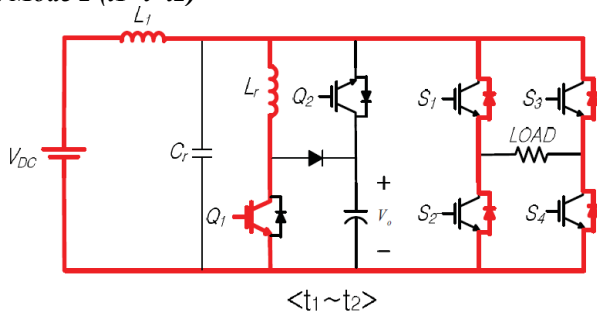

When the resonant capacitor is fully discharged to Mode1, the anti-parallel diodes in inverter switches constitute current path. At this time, the inverter stage is zero. When the inverter stage is in the zero voltage condition, the inverter switches are given to PWM signal (S1, S4). So, inverter switches are turned on and off with ZVS. This mode is maintained when the main switch is turned-off. The main inductor current is given by Mode 2 ($t_1 < t < t_2$): When the resonant capacitor is fully discharged to Mode1, the anti-parallel diodes in inverter switches constitute current path. At this time, the inverter stage is zero. When the inverter stage is in the zero voltage condition, the inverter switches are given to PWM signal (S1, S4). So, inverter switches are turned on and off with ZVS. This mode is maintained when the main switch is turned-off. The main inductor current is given by.

$$I_{L1}(t) = I_{L1}(t_1) + V_{in}/L(t_2 - t_1) \quad (9)$$

The resonant inductor current and resonant capacitor voltage

are given by

$$i_{Lr}(t) \equiv i_{Lr}(t_1) \equiv i_{Lr}(t_2) \quad (10)$$

$$V_{cr}(t_1) \equiv V_{cr}(t_2) \equiv 0V \quad (11)$$

C. Mode 3 ($t_2 < t < t_3$):

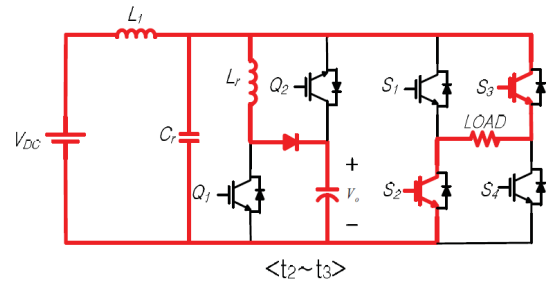

When the switch is turned off with ZVS, the resonant inductor releases energy. Thus, the bridge diode is turned on. The dc-link capacitor is transferred to main inductor and resonant inductor energy through the bridge diode. The resonant capacitor starts to charge main inductor energy. At that time, the resonant inductor current and resonant capacitor voltage are given by

$$i_{Lr}(t) = v_0 + (I_{in}/C - v_0) \cos \omega_r (t_3 - t_2) - I_{L(0)}/Z_r \sin \omega_r (t_3 - t_2) \quad (12)$$

$$V_{cr}(t) = v_0 - v_0 \cos \omega_r (t_3 - t_2) + Z_r (I_{in} - I_0 - I_{L(0)}) \sin \omega_r (t_3 - t_2) \quad (13)$$

$$i_{L1}(t_3) \equiv 0 \quad (14)$$

In this mode, the main inductor current is given by

$$I_{L1}(t) = I_{L2}(t_2) - v_0 - v_{in}/L(t_3 - t_2) \quad (15)$$

$$I_{L1}(t_2) \equiv I_{max} \quad (16)$$

D. Mode4 ($t_3 < t < t_4$)

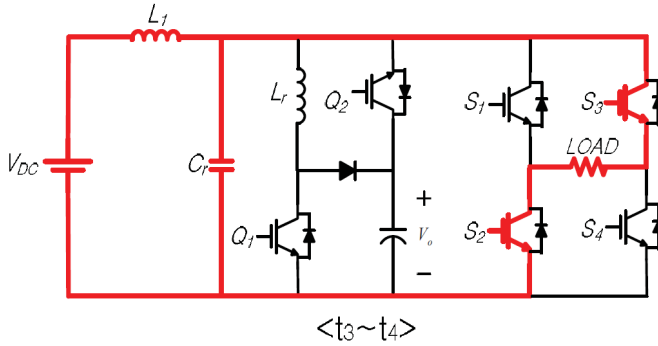

When the resonant inductor energy is fully released, the bridge diode is turned-off. This mode is maintained until the resonant capacitor voltage becomes 400[V]. The main inductor current flows continuously through the inverter switches (S1, S4). In this mode, resonant capacitor voltage is given by

$$v_a(t) = I_{L1} - I_0 / C(t_4 - t_5) + V_c(t_3) \quad (17)$$

$$V_{cr}(t_4) \equiv V_{out} \quad (18)$$

Resonant inductor current is given by

$$i_{Lr}(t_3) \equiv i_{Lr}(t_4) \equiv 0 \quad (19)$$

E. Mode 5 ($t_4 < t < t_5$)

This mode is started when the resonant

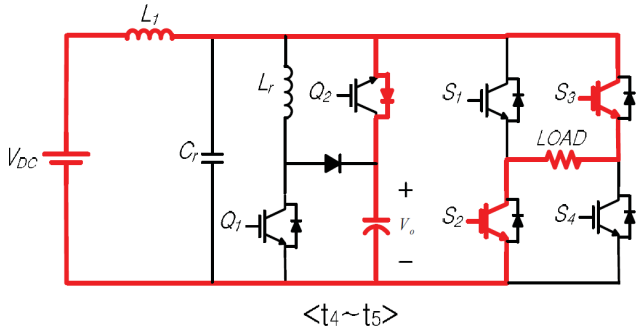

This mode is started when the resonant capacitor is fully charged. After that, the auxiliary switch is turned on with ZVS because the switch voltage is zero. When the main inductor current decreases linearly, the dc-link capacitor is charged from the main inductor energy. Because the main inductor current flows through the anti-parallel diode, the auxiliary switch voltage is zero voltage. When the auxiliary switch current path is changed, the next mode starts. In this mode, the main inductor current can be expressed as

$$I_{L1}(t) = I_{L1}(t_4) - V_0 - V_{in} / L(t_5 - t_4) \quad (20)$$

F. Mode6 ($t_5 < t < t_6$)

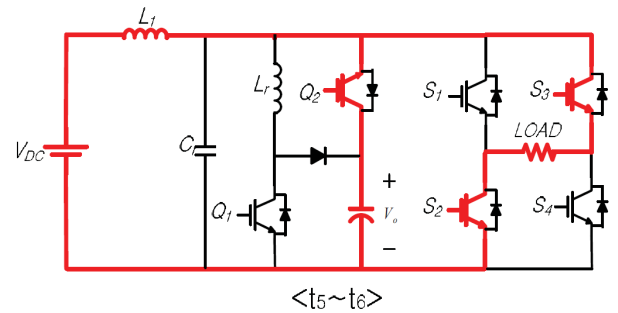

In this mode, the auxiliary switch current path is changed because the dc-link capacitor starts to discharge. Therefore, the load is supplied the energy by the dc-link capacitor and main inductor. This mode maintains that the main inductor current equal to the resonant current. The main inductor current in this mode is expressed as

$$I_{L1}(t) = I_{L1}(t_5) - V_0 - V_{in} / L(t_6 - t_5) \quad (21)$$

$$i_{L1}(t_6) \equiv I_{min} \quad (22)$$

$$i_{Lr}(t_5) \equiv i_{Lr}(t_6) \equiv 0 \quad (23)$$

$$V_{cr}(t_4) \equiv V_{out} \quad (24)$$

After this mode ends, returning the mode 1.

WAVEFORM

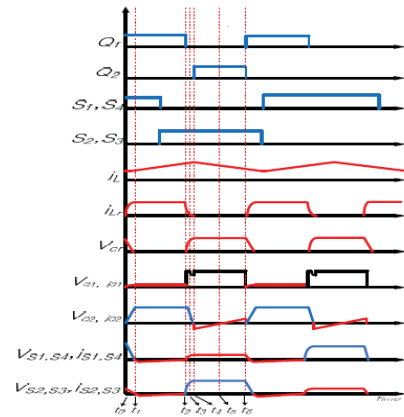

Fig.3 Operation waveforms for the novel DC-AC single phase resonant inverter using soft-switching boost converter

IV. SIMULATION MODEL

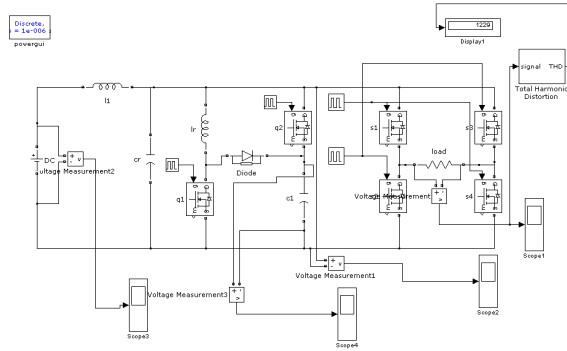

Fig.8 Designed Simulation Model For A Novel Dc-Ac Single Phase Resonant Inverter Using Soft Switching Boost Converter With R- Load with resonating components.

A. Simulation Parameters Used:

| | |
|----------------------|----------------|
| Vdc | 200[V] |
| Vdc-link | 400[V] |
| Main inductor | 1000[μ H] |
| Resonant inductor | 10[μ H] |
| Resonant capacitor | 10[nF] |
| DC-Link-Cap | 1000[μ F] |
| Con. Switching Freq. | 30[kHz] |
| Inv. Switching Freq. | 15[kHz] |

Fig.9 Simulation Parameters Used

V. SIMULATION RESULTS

A. Input Voltage Of A Novel Dc-Ac Single Phase Resonant Inverter Using Soft Switching Boost Converter:

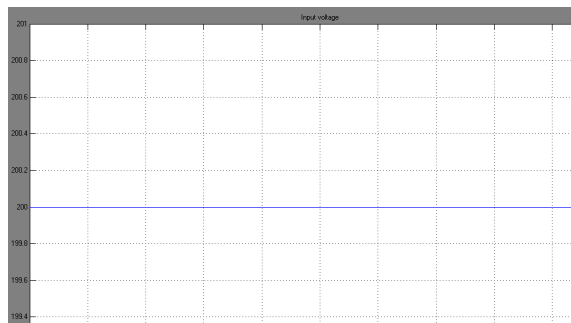

Fig.10 Input Voltage of a Novel Dc-Ac Single Phase Resonant Inverter Using Soft Switching Boost Converter

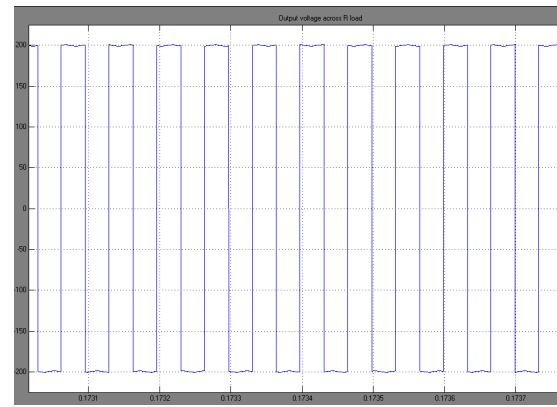

Fig.11 Output Voltage of a Novel Dc-Ac Single Phase Resonant Inverter across R-load

B. Voltage in the Boost Converter:

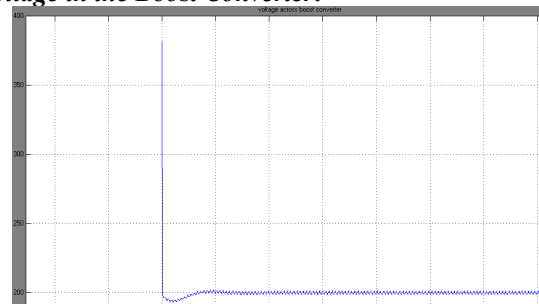

Fig.12. Voltage in the Boost Converter

C. Voltage across Dc-Link Capacitor:

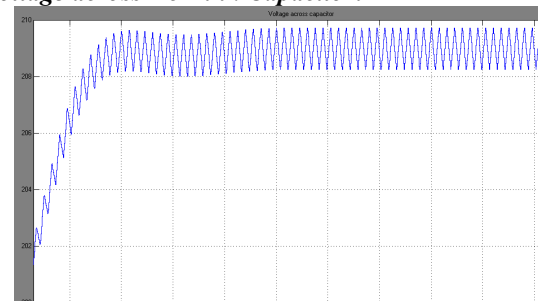

Fig.13 Voltage across Dc-Link Capacitor

VI.SIMULATIONMODEL

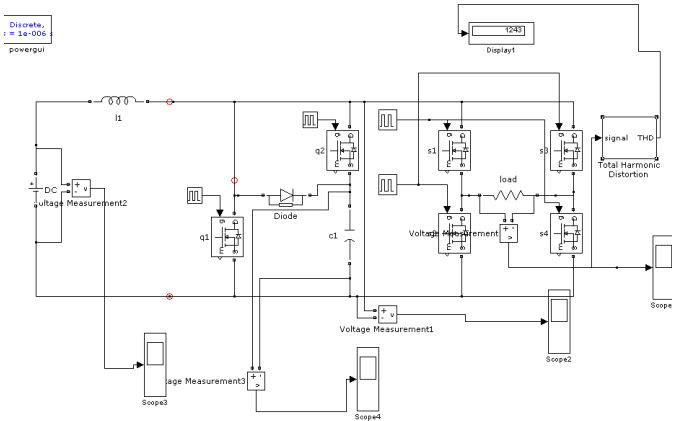

Fig.14. Designed Simulation Model For A Novel Dc-Ac Single Phase Resonant Inverter Using Soft Switching Boost Converter With R- Load without resonating components.

A. Simulation Parameters Used

| | |
|----------------------|----------|
| Vdc | 200[V] |
| Vdc-link | 400[V] |
| Main inductor | 1000[μH] |
| Resonant inductor | 10[μH] |
| Resonant capacitor | 10[nF] |
| DC-Link-Cap | 1000[μF] |
| Con. Switching Freq. | 30[kHz] |
| Inv. Switching Freq. | 15[kHz] |

Fig.15 Simulation Parameters Used

VII. SIMULATION RESULTS

A. Input Voltage Of A Novel Dc-Ac Single Phase Resonant Inverter Using Soft Switching Boost Converter:

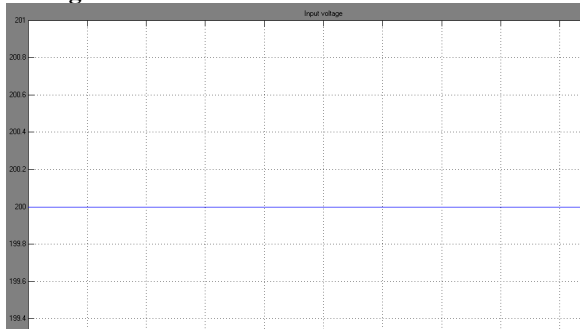

Fig.16. Input Voltage of a Novel Dc-Ac Single Phase Resonant Inverter Using Soft Switching Boost Converter

B. Output Voltage across R load:

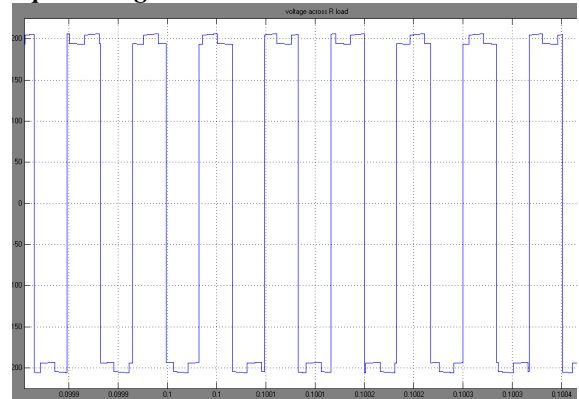

Fig.17. Output Voltage of a Novel Dc-Ac Single Phase Resonant Inverter across R load

C. Voltage in the Boost Converter:

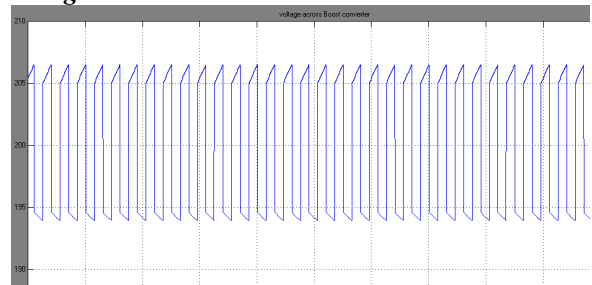

Fig.18 Voltage in the Boost Converter

D. Voltage across Dc-Link Capacitor:

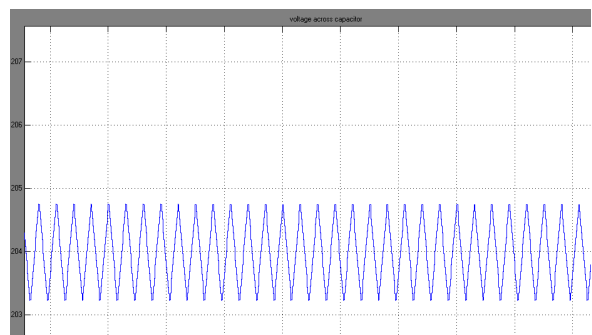

Fig.19. Voltage across Dc-Link Capacitor

VIII. APPLICATIONS

This type of inverter produces an approximately sinusoidal waveform at a high output frequency, ranging from 200 to 100 kHz, and is commonly used in relatively fixed output applications, for example, induction heating, sonar transmitter, fluorescent lighting, or ultrasonic generators. Due to the high switching frequency, the size of the resonating components is small.

- a. Industrial Applications.
- b. Instrumentation.
- c. Servo Applications.
- d. Microwave Oven Control.
- e. Refrigerators.

IX. CONCLUSION

In this paper, we proposed a novel DC-AC single phase resonant inverter using soft-switching boost converter. In this topology, all switches perform a soft switching by resonance between the resonant inductor and capacitor. So, the proposed topology can reduce the switching loss and voltage stress. The proposed inverter is analyzed through the operation mode, and its validity is proven through simulation.

ACKNOWLEDGMENT

This work is outcome of the fostering project of the Specialized Graduate School supported financial Ministry of Knowledge Economy (MKE).

REFERENCES

- [1] D. M. Divan, G. Skibinski, "Zero switching loss inverters for high Power applications," IEEE IAS Rec., pp. 627-634, 1987.
- [2] S.R. Park, S.H. Park, C.Y. Won, Y.C. Jung, "Low loss soft switching Boost converter", 2008 13th International Power Electronics and Motion Control Conference (EPE-PEMC 2008) pp. 181 - 186. 2008
- [3] K. Wang, G. Hua, and F. C. Lee, "Analysis, design and ZCS-PWM Boost converters" in Proc. IEEJ Int. Power Electronics Conf., pp.1202-1207, 1995
- [4] G. Hua, X. Yang, Y. Jiang, and F.C. Lee, "Novel zero-current-transition PWM converter", IEEE Power Electronics Specialist Conf. Rec., pp.538-544, 1993.
- [5] H. Ohashi, "Power Electronics Innovation with Next Generation Advanced Power Devices", Proceeding of INTELEC'03, Oct.2003, Yokohama (Japan), pp.9-13
- [6] D. M. Divan and G. Skibinski, "Zero switching loss inverters for high Power applications," IEEE IAS Rec., pp. 627-634, 1987.