

Performance Analysis of Rake Receiver for SUI Channel Modelling

Shital B. Kumbhalkar¹, Prashant R. Khond² and D. Sailaja³

^{1,3}Department of Electronics and Communication Engineering,
Sree Kavitha Engineering College, JNTU Hyderabad, Andhra Pradesh, India
²Ballarpur Institute of Technology, RTM Nagpur University, Maharashtra, India
E-mail: ^{1,3}skumbhalkar9@gmail.com, sailajadasare@gmail.com, ²vrkhond@gmail.com

(Received 9 October 2014; Revised 18 October 2014; Accepted 5 November 2014; Available online 15 November 2014)

Abstract - This paper is concerned about the performance of UWB system in the multiuser environment. The existence of several multiuser access can cause a significant performance degradation and hence the transmission rate. In this paper, an adaptive least bit error rate (LBER) Rake receiver used for synchronous CDMA UWB system for SUI channel modelling to mitigate multiple access interference and inter symbol interference. Combining weights of Rake receiver is adapted based on the LBER criteria and calculate the cumulative results. BER performance of the conventional MRC, MMSE and LBER Rake receiver can be studied by varying the number of fingers for different number of users and also compare with SUI channel. The conditional probability density function for the output signal is generated to analyze the effect of MAI and ISI at the receiver side. The proposed LBER Rake receiver with SUI channel shows that receiver can suppress MAI and ISI more effectively and also have the lowest path loss in the multiuser environment hence increases the number of active user and transmission rate.

Keywords: Ultra-Wideband, Rake Receiver, Stanford University Interim Model, Multiuser Access Interference, Intersymbol Interference, Least Bit Error, Minimum Mean Square Error.

I. INTRODUCTION

In recent year, ultra-wideband (UWB) communication has captured the interest of research communities worldwide, because it provides high-speed digital connections between PCs and digital peripherals [6]. Ultra-Wideband system (UWB) with spread-spectrum (SS) technique gives a tremendous result in multiple access wireless communication. The search for a utilization of a very wide transmission information measure ends in nineties to satisfy the stress of future wireless network. In addition to this, it also provide position location, immunity to narrowband interference, multiple access capability, covert transmission and lustiness against multipath attenuation [1]. Hence, in this paper DS-UWB standard is used, due to its simplicity and highly orthogonality. The multiple access technique used in proposed system is Code Division Multiple Access (CDMA).

In CDMA-UWB system, the narrowband message signal is multiplied by a very large bandwidth signal called the spreading signal. The spreading signal has a chip rate which is much greater than the data rate of the message signals. In CDMA-UWB system, each user assigns a unique code

which is different from other and hence high orthogonality is maintained between the users for sharing the channel simultaneously. The orthogonality between the users is destroyed at the receiver side as the intermodulation products are generated due to interference and limits the total number of user sharing the same channel. To eliminate this effect, different multiuser detection technique have been proposed [1-2,7-8]. One of the most widely used technique is the adaptive multiuser detection (MUD) in which the minimum mean square error criterion is used to eliminate ISI and MAI [7-8]. An adaptive MUD can be introduced after the Rake receiver [2]. The Rake receiver work on the principle of multipath diversity, where the Rake receiver first attempt to resolve multipath component and improve quality of reception by collecting time delay version of the original transmitted signal. Rake receiver quality goes up linearly for every path whose energy is exploited, whereas MMSE quality is constant and continuously exploits for all multipath energy that falls in its observation window and is resolvable [5]. In addition to this, the MMSE has the advantage of suppressing intersymbol interference (ISI) attributable at the observation window, while the Rake receiver rejects solely to the amount of the processing gain. Even though the adaptive MUD with MMSE criterion does not give the desired bit error rate performance in multiuser environment [9-11].

In this paper, we use the MBER criterion to obtain the Rake finger coefficient for computing results. The proposed adaptive Rake receiver uses least mean square algorithm [9] with a SUI channel modeling to increase the BER performance. Unlike many other forms of assessment, bit error rate gives overall performance of a system including the transmitter, receiver and medium. In BER performance evaluation, the more concentration is given to the overall operation of the system rather than testing the component parts and hoping. Hence to increase the performance of the system SUI channel is used, in which the bit error rate noise and propagation path loss both are reduced and also increase efficiency of the system. The conditional probability density function at the receiver side is generated to analyze the effect of inter symbol interference and multi access interference and also to increase the system performance [4].

II. ANALYTICAL MODELLING FOR MULTIUSER UWB SYSTEM MODEL

In this section modulation technique for transmission and reception of data has been explained. Consider DS-UWB system in which the BPSK technique is used for the single user which is given by [3]:

$$b(t) = \sum_{i=-\infty}^{\infty} d[i]p(t - iT_c) \quad (1)$$

Where data symbol $\{d[i]\} \in \{-1,1\}$ for BPSK, i being the symbol index and $p(t)$ represents the delayed version of UWB pulses with a symbol duration T_{sym} i.e. $T_{sym} = JT_c$.

$$p(t) = \sum_{j=0}^{J-1} c[j]g(t - jT_c) \quad (2)$$

Where $\{c[i]\} \in \{1,0\}$ represents the relative pulse timing within a symbol and also representing the time hopping codes and spacing between the pulses for the j^{th} chip of the UWB spreading of length J , T_c is the chip duration of the UWB system, $g(t)$ is the channel response which is either first or second derivative of a Gaussian pulse.

Digital modulation involves choosing a particular signal waveform $S_i(t)$ from a finite set of symbols based on the $b_i(t)$ information bit applied for modulation. If L is the total number of users then modulation signal set S can be represented as

$$S = \{S_1(t), S_2(t), \dots, S_L(t)\} \quad (3)$$

Therefore the transmitted multi-user CDMA UWB signal for this vector space can be represented by:

$$s(t) = \sum_{i=1}^L s_i(t)b_i(t) \quad (4)$$

As the DS-CDMA technique has been used, gold codes are transmitted for spreading the data due to their high orthogonality values in synchronous condition. The channel impulse response can be generated according to Saleh-Valenzuela model or any of its derivatives for UWB channel with slight modulation consisting of M clusters for K multipath components [3]:

$$h_i(t) = G_i \sum_{m=0}^M \sum_{k=0}^K \alpha_{k,m}^i \delta(t - T_m^i - \tau_{k,m}^i) \quad (5)$$

Where G_i represent the amplitude gain of the log normal showing, T_m^i is the delayed pulse of m^{th} clusters, $\alpha_{k,m}^i$ is the gain coefficient and $\tau_{k,m}^i$ is delay of m^{th} multipath component relative to the m^{th} cluster and $\delta(\cdot)$ is the Dirac delta pulses used in order to express a realization and simulation of channel impulse response.

The receiver consists of combination of match filter with an impulse response followed by a rake receiver to decode the data. As the BPSK modulation has been used at transmitter side, coherent detection is used to recover the original data at the receiver side. In the coherent technique, a phase synchronize carrier to be generated at the receiver to recover the information signal. Coherent technique is complex but it gives the better performance. The received signal after passing through the multipath communicating channel is given as[2]:

$$r(t) = \sum_{n=0}^N h_n(t)s(t) + \varnothing(t) \quad (6)$$

Where $\varnothing(t)$ is the amount of noise introduced by the L number of user in N channels.

If multipath components arriving randomly at different angle, they are superimposed on nonfading signals. At this particular instant, the output of an envelope detector has the Ricean distribution. Hence to increase the performance of the system at multipath environment SUI channel modeling is used with microscopic effect i.e. tapped delay line, fading, antenna diversity to describe the statistical time varying nature of the received envelope. Therefore the received signal passed through a bank of correlator is given by;

$$y_1(t) = r(t)S_1(t) \quad (7)$$

If only first user is considered, then the output from the bank of correlator can be rewritten as

$$y_1(t) = r(t)S_1(t) \quad (8)$$

$$= \sum_{n=0}^N h_n(t)s(t)S_1(t) + \varnothing(t)S_1(t) \quad (9)$$

$$= \sum_{n=0}^N h_n(t) \alpha_1 + \sum_{i=0}^N \sum_{j=0}^K h_i(t) S_{1j}(t) \alpha_j + S_1(t) \varnothing(t) \quad (10)$$

Where, equation (10) denotes the combined effect of ISI, MAI and noise on the information signal. First term represents the user information with ISI, middle term represents MAI and the last term is noise component. In this paper, the main goal is to suppress the MAI and ISI effectively and also to increase the bit error rate performance by using SUI channel modelling.

III. ANALYSIS OF ADAPTIVE RAKE RECEIVER FOR CDMA UWB SYSTEM

Figure 1 shows the block diagram of adaptive Rake receiver for Q fingers is given by [1]

$$f(t) = \sum_{q=0}^{Q-1} \beta_q \gamma_q(t - \theta_q) \quad (11)$$

Where β_q is the Rake coefficients whose value is $\beta_q = [\beta_0, \beta_1, \dots, \beta_{Q-1}]$ and θ_q are the finger delays i.e. $\theta_q = [\theta_0, \theta_1, \dots, \theta_{Q-1}]$. Assume that, the value of θ_q is quarter of symbol period [1], the output of over sampled signal can be written as:

$$f(k) = \sum_{q=0}^{Q-1} \beta_q y'_q(k - \tau) \quad (12)$$

Where, y'_q is the output of vector for over sampled signals.

The decision device $x(k)$ will take a decision simply from the sign of $f(k)$:

$$x(k) = \text{sgn}(f(k)) \quad (13)$$

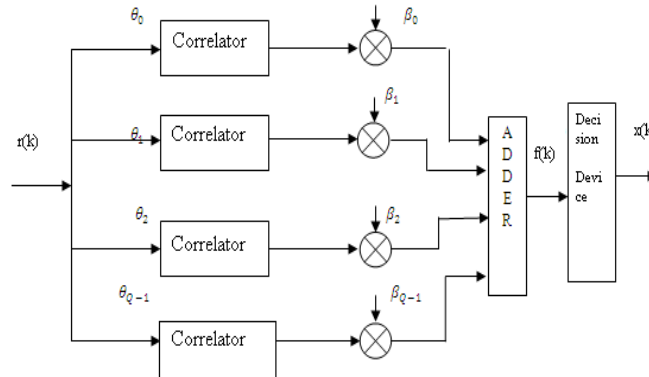

Fig. 1 Block Diagram of Adaptive Rake Receiver

A. Adaptive MMSC Rake Receiver

In MMSE, attention is paid to the Rake weights. Basically, the weight vector is improved for each iteration to minimize the mean square error after equalization [2]. The expression for adaptive MMSE is given by

$$\beta_{MMSE} = \arg \min_{\beta} MSE \quad (14)$$

Where, MSE is mean square error which is given by

$$MSE = E[f(k) - x(k-D)]^2 \quad (15)$$

D is the delays in channel and receiver. Here we have to assume that correlation having a perfect knowledge of the channel delays and amplitude. The adaptive algorithm for the receiver is given by [4]:

$$\beta_{q+1} = \beta_q + \mu [f(k) - x(k-D)] y'_q(k) \quad (16)$$

Where μ is the uniform step size.

B. Adaptive LBER Rake Receiver

The least mean square algorithm works on the principle of, it searches for the optimum or near optimum filter weights for each iterative operation. The constant value in iteration may be adjusted by the algorithm to control the variations between filter weights on successive iteration. This process is repeated rapidly in programming loops while the equalizer attempts to converge for minimizing the error. Therefore the MBER criterion is formulated to minimize the bit error rate after each iterative equalization [9]:

$$\beta_{MBER} = \arg \min_{\beta} P_E \quad (17)$$

Where P_E is the probability of errors;

$$P_E = \int_{-\infty}^{\infty} p(z; \beta) dz \quad (18)$$

In equation (13), $P(z; \beta)$ is the probability density function which is given by [10];

$$P(z; \beta) = \frac{1}{\sqrt{2\pi} \sqrt{\sum_{k=1}^K \beta_k^2}} \exp \left[-\frac{(z - z'(k))^2}{2 \sum_{k=1}^K \beta_k^2} \right] \quad (19)$$

Where k is bit sequence of $b(t)$, σ^2 is variance, $z = f$ and $z'(k)$ is the decision variable of $z'(k) = x(k) \cdot f(k)$.

Thus, the bit error rate measure for Rake receiver is given by:

$$P_E = \frac{1}{\sqrt{2\pi} \sqrt{\sum_{k=1}^K \beta_k^2}} \times \sum_{k=1}^K \int_{-\infty}^{\infty} \exp \left[-\frac{(z - z'(k))^2}{2 \sum_{k=1}^K \beta_k^2} \right] dz \quad (20)$$

$$= \frac{1}{K} \sum_{k=1}^K Q(Q(k)) \quad (21)$$

Where $g(k) = \frac{\beta_q}{\sqrt{\beta_q^2 + \beta_q^2}}$.

By equalizing β_q into $\frac{\beta_q}{\sqrt{\beta_q^2 + \beta_q^2}}$ to get the fix solution of a unit vector energy [2] and also replacing the oversampled output

$f(k)$ from the Rake fingers ,the gradient of P_E with respect to β_q is defined as

$$\nabla P_E = \frac{1}{2\sigma^2 \sum_{k=1}^K \exp\left[-\frac{f(k)^2}{2\sigma^2}\right]} \times x(k) \cdot y'_q(k) \quad (22)$$

To minimize error at the receiver output, many techniques such as gradient or steepest decent algorithm has been used to attempt convergence and then freezes the filter weights until the error signal exceeds an acceptable level. Therefore the Rake finger coefficient for this algorithm is given by

$$\beta_{q+1} = \beta_q - \mu \nabla P_E \quad (23)$$

Therefore the LMS algorithm for the optimum filter to performance the iterative operation is given by

New weights = Previous weights + (constant) \times (Previous error) \times (current input vector)

This can be applied to the equation (16) by replacing $K=1$ and σ as the radius parameter by ρ . Therefore the proposed adaptive LBER Rake receiver is given by cf((23)):

$$\beta_{q+1} = \beta_q + \frac{\mu}{\sqrt{2\pi\rho}} \exp\left[-\frac{f(k)^2}{2\rho^2}\right] \times x(k) \cdot y'_q(k) \quad (24)$$

IV. STANFORD UNIVERSITY INTERIM MODEL

Small scale fading or fading is the variation in amplitude, phase or multipath delay of radio signal over a short period of time. Fading is caused by interference between two or more version of the transmitted signal which arrives at the receiver at different time. These waves called as multipath wave. In proposed system, the transmission is at the multipath environment is occurred, hence to increase the BER performance i.e., to minimize the error, SUI channel is used. In multipath channel environment, most important effect has been considered i.e., fluctuation in signal strength over a small interval of time, variation in frequency modulation due to varying doppler shift on different multipath signals and time dispersion(echoes) causes by multipath propagation delays.

SUI channel has been developed by Stanford University for IEEE 802.16. It is used for frequency higher than 1900MHz. The SUI channel can be used for the fixed broadband wireless application [13]. In this propagation model, three different types of terrains are considered, ‘A’ represents an area with the highest path loss for highly dense populated region while ‘B’ represents the sub urban environment with moderate path loss and ‘C’ is a rural or flat area with the least amount of path loss. A set of 6 typical SUI channel were selected to represent 3 different

terrains for specifying statistical parameter of microscopic effect such as Doppler spread, delay spread and LOS or NLOS condition [12].

TABLE I PARAMETRIC VIEW OF SUI CHANNEL FOR 3 DIFFERENT TERRAINS.

Channel	Terrain Type	Doppler Spread	Spread	LOS
SUI-1	C	Low	Low	High
SUI-2	C	Low	Low	High
SUI-3	B	Low	Low	Low
SUI-4	B	High	Moderate	Low
SUI-5	A	Low	High	Low
SUI-6	A	High	High	Low

The general structure for SUI channel model is shown below. It is a three tapped delay model combined the effect of path loss and shadowing (excess path loss) to overcome the noise at channel. For each tap, zero mean gaussian distribution is generated with a variance of 0.5 for real as well as imaginary parts, so that the total average power become 1[14].

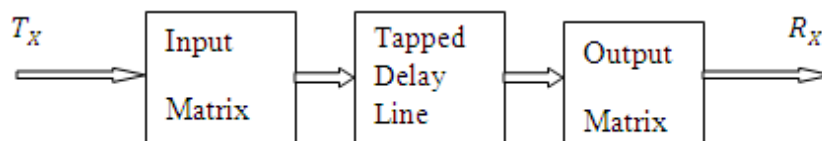

Fig. 2 Block Diagram of SUI channel Model.

The function of each section in the block diagram is as follow:

Input Matrix:-The signals from the transmitter are directly fed for correlation to the input side for modeling if multiple transmitting antennas are used.

Tapped delay line matrix:-This is intermediate stage, in which the multipath fading has been modeled with a 3 taps of non uniform delay. The gain associated with each tap is characterized by Rayleigh distribution with $K=0$ for the magnitude of complex coefficient, Ricean distribution with $K > 0$ for constant part component and also the maximum Doppler frequency. Where K is the ratio of power between constant part and Rayleigh (variable) part of the component.

Output matrix:-This is the last stage, in which the correlation between the output signals are modeled if multiple receiving antennas are used.

Therefore, the probability density function of received power ‘r’ for Ricean distribution is given by

$$P_r = \frac{r}{\sigma^2} e^{-\left(\frac{r^2 + A^2}{2\sigma^2}\right)} I_0\left(\frac{rA}{\sigma^2}\right) \quad 0 \leq r < \infty \quad (25)$$

Here, σ^2 is the time average power of the received signal. $I_0(\cdot)$ is the modified Bessel function of the first kind zero order and ‘A’ denotes the peak amplitude of the dominant signal. If there is no LOS component then the value of A becomes 0 and pdf of such a received signal can be defined by Rayleigh distribution which is given by cf((25)):

$$P_r = \frac{r}{\sigma^2} e^{-\left(\frac{r^2}{2\sigma^2}\right)} \quad 0 \leq r < \infty \quad (26)$$

The ratio $\frac{A^2}{2\sigma^2}$ in equation (21) represent by K i.e., $K = \frac{A^2}{2\sigma^2}$ is called as K factor or Ricean factor. It represents ratio of LOS components to NLOS components. In other words, it is the ratio between the deterministic signal power and variance of the multipath. As $A \rightarrow 0$, $K \rightarrow \infty$, decreasing the amplitude of dominant path, converting Ricean distribution into the Rayleigh distribution.

V. RESULTS AND DISCUSSION

In this section, the performance of three different types of Rake receiver i.e. adaptive MMSE, MRC and proposed adaptive LBER Rake receiver for SUI channel is presented.

A. Simulation Parameters

In this section, different UWB parameter is defined, the UWB chip spreading, $c[i]$ is set of [1 0 0 0], step size μ of 0.002 for MMSE as well as adaptive LBER Rake receiver, the radius of receiver is $\rho^2 = 0.796$. Simulation is performed over a 100 channels i.e., $N_c = 100$. Therefore, the impulse response is averaged over 100 channel for iterative algorithm. The performance of receiver has been studied by varying the Rake fingers and total number of user L for the SUI channel. As the coherent receiver used, we assume that the receiver is perfectly synchronized and having the knowledge of finger delays τ_q .

B. BER Performance

Figure 3 shows the comparison of BER performance of the Rake receiver for MMSE and LBER for different number of fingers. It is observed that the proposed LBER Rake receiver attain good BER performance as compare to MMSE. Furthermore, LBER-20 Rake receiver indicate that using fewer fingers LBER Rake receiver can reduce the intersymbol interference and multiuser access interference more effectively as compare to the MMSE Rake receiver.

Figure 4 shows BER performance comparison of the conventional maximum ratio combining (MRC) rake receiver, adaptive MMSE Rake receiver and adaptive LBER Rake receiver are made by varying the number of fingers for SUI channel. The LBER with 10 fingers gives minimum bit error rate as compare to MMSE and MRC Rake receiver for SUI channel. Hence, the proposed adaptive LBER Rake receiver is more effective to minimize the effect of MAI and also for suppressing sufficient amount of ISI and supporting large number of active user at a lower bit error rate and higher data transmission rate for SUI channel. In otherwords, the LBER receiver can support more number of active users for transmission of data in the presence of MAI and ISI than MRC and adaptive MMSE Rake receiver.

C. Result Analysis

In all results presented in this proposed system, the great impact of SUI channel modelling for DS-UWB multichannel system is observed. For some purpose it can be required to have the SUI channel coefficient as an arbitrary observation rates i.e. data rate to predict the path loss and minimize the MAI in all multipath environment. The conditional probability density function are used to separate out the mean value closer to transmitted signal than that of proposed LBER Rake receiver and MMSE Rake receiver. Among both the receiver, the LBER Rake receiver are found to be best fit for suppressing MAI and increasing bit error rate performance. In other words, the LBER Rake receiver is more robust in noisy environment. Figure 4 shows that, the accuracy of estimated results for LBER Rake receiver is less affected by noise introduced in

the multi-path environment for SUI channel. Hence, the proposed receiver is more preferable in multiuser DS-UWB environment for SUI channel to obtain a better BER performance and increases the transmission rate and hence efficiency of system.

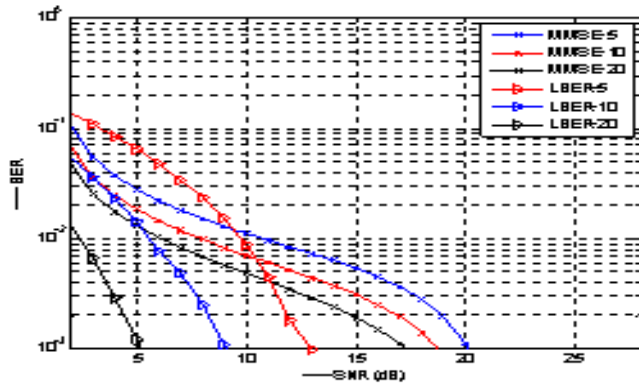

Fig. 3 Comparison of Rake receivers for different number of fingers.

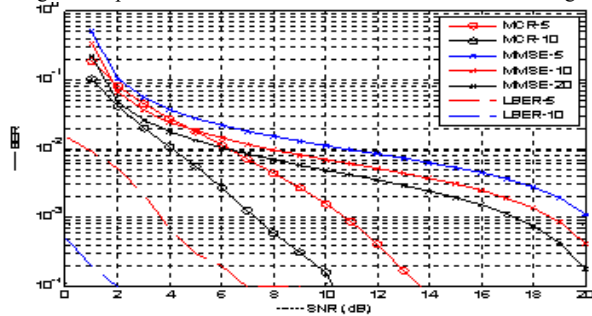

Fig. 4 BER Performance comparison of Rake receiver for SUI channel.

VI. CONCLUSION

An adaptive least bit error rate (LBER) Rake receiver for synchronous CDMA UWB system for SUI channel has been proposed to increase the BER performance. For this, a set of six channels for fixed broadband wireless systems are used to derive the path loss and multipath fading model to mitigate ISI and MAI. The performance of the system for multiple accesses has been analyzed in terms of error probability, data transmission rate and number of active users in the specified multipath fading channel. It shows that, SUI channel give better BER performance as compare to other channels. It has been demonstrated using the SUI channel modelling, LBER Rake receiver want fewer fingers to achieve desired BER performance over the MRC Rake

receiver and MMSE Rake receiver. Hence it has been concluded that the proposed adaptive LBER Rake receiver is found to have better ability of suppressing ISI and MAI more effectively as compared to the other receivers for DS-UWB system. Future work can be achieved by extending the proposed receiver to nonlinear receiver for SUI channel.

REFERENCES

- [1] D. Cassioli, M. Z. Win, F. Vatalaro and A. F. Molisch, "Low Complexity Rake Receivers in Ultra-Wideband Channel," 4th IEEE transactions on wireless communications, vol. 6, no. 4, April 2007.
- [2] M. Eslami, and X. Dong, "Rake-MMSE-Equalizer Performance for UWB," *IEEE Communications Letters*, vol. 9, no. 6, pp. 502 - 504, June 2005.
- [3] C. R. Aderson, J.H. Reed, R.M. Buehre, D.Sweeney and S.Griggs, *Introduction to Ultra Wideband Communication System*, Prentice Hall PTR, USA, 2005.
- [4] G. C. Chung, "Multi-user Access Interference Suppression for UWB System", 2012 International Conference on Computer & Information Science (ICIS).
- [5] U. Madhow, "Blind adaptive interference suppression for direct-sequence CDMA," *Proc. IEEE*, vol.86, pp. 2049-2069, Oct. 1998.
- [6] R.Kshetrimayum, "An Introduction to UWB Communication System", *IEEE Potentials*, vol.28, Issue 2, pp.9-13, March-April 2009.
- [7] M. R. Gajbhiye, "Performance comparison of MMSE-based adaptive multiuser detection of DS-SS CDMA signals," *Industrial Electronics, control & Robotics Conference (IECR)*, pp.71-76, 27-29 December 2010.
- [8] K. Jeong, M. Yokoyama, and H. Uehara, "A Time-Varying Modified MMSE Detector for Multirate CDMA Signals in Fast Rayleigh Fading Channels", *ETRI Journal*, vol.29, No.2, April 2007.
- [9] S. Chen, Ahmad K. Samingan, and B. Mulgrew, "Adaptive Minimum-BER Linear Multiuser Detection for DS-SS Signals in Multipath Channels," *IEEE Transactions on Signal Processing*, vol.349, issue 6, pp. 1240 - 1247, June 2001.
- [10] C.C.Yeh, and J.R. Barry, "Adaptive Minimum Bit-error-rate Filtering," *IEEE Transactions on Vision, Image & Signal Processing*, vol.49, issue 6, pp.1240-1247, June 2001.
- [11] S. Chen, S. Tan, L. Xu and L. Hanzo, "ADAPTIVE Minimum error rate Filter design review," *IEEE Transaction on Signal Processing*, vol.88, issue 7, pp.1671-1679, 2008.
- [12] N. Shabbir, M.T. Sadiq, H. Kashif, and Rizwan Ullah, "Comparison of Radio Propagation Models For Long Term Evolution Network", *IJNGN Journal*, vol.3, No.3, september 2011.
- [13] V.S. Abhayawardhana, I.J. Wassel, d. Crosby, M.P. Sellers, M.G. Brown, "Comparison of empirical propagation path loss models for fixed wireless access systems," 61th IEEE Technology Conference, Stockholm, pp.73-77, 2005.
- [14] D.S. Baum, "Simulating the SUI Channel Models", *IEEE 802.16.3c-01/53*, 2001.