

# Optimised Adaptive Controller for an Interacting System

S. Preethi<sup>1</sup> and A. Sanjeevi Gandhi<sup>2</sup>

<sup>1</sup>Department of Electronics and Instrumentation, Karunya University, Coimbatore - 641 114. Tamil Nadu, India

Email: spreethi128@gmail.com

(Received on 27 February 2013 and accepted on 15 May 2013)

**Abstract** - In this paper, a method for controlling multivariable process is presented. The system under investigation is a two tank interacting process. A decoupler is designed in order to minimize the interaction effects. Then, the Model Reference Adaptive Controller is designed for the process with decoupler block. The tuning parameter is optimised using Genetic Algorithm. Optimised Model Reference Adaptive Controller was then compared with conventional controllers. The performance comparisons have been made in terms of rise time, settling time and performance criteria.

**Keywords** : Multi Input Multi Output, Model Reference Adaptive Control, Two Inputs Two Outputs

## I. INTRODUCTION

The processes encountered in the real world are generally Multiple Input Multiple Output (MIMO) systems [8]. The level control applications are tremendous especially in chemical process industries. The traditional control such as the classical feedback control, modern control theory has encountered many difficulties in its applications. The design and analysis of these control systems are established on their accurate mathematical models which are usually very difficult to achieve outstanding to the complexity, nonlinearity, time varying and incomplete characteristics of the existing realistic systems. One of the most effectual ways to solve the problem is to use the technique of adaptive control system.

A multivariable system consists of decomposing the design problem into two parts: The first part consists of decoupling the system in order to minimize interaction then, design the controllers using some decentralized method. The final control system will be the multiplication of the decoupling and the controller matrices. The Decouplers, along with Model reference adaptive controller constitutes an adaptive controller. MRAC or model reference adaptive control which is one of a kind in adaptive control techniques

is implemented. The desired performance is expressed in terms of reference model, which gives the desired response to a command signal. The desired parameters for the system were first established using Model Reference Adaptive Control and then the Genetic Algorithm is used to optimize the tuning parameter. Therefore, fast convergence to global optimal is obtained.

In this paper the Model Reference Adaptive Controller and an Optimised Model Reference adaptive controller is designed and compared for a two tank interacting process. Section II describes the process. Section III explains Controller Design. Section IV deals with Results and Discussion. Then in section V the conclusion and future remarks are given.

## II. PROCESS DESCRIPTION

Consider the two tank interacting process as shown in Fig.1. This consists of two cylindrical tanks (Tank 1 and Tank 2), two independent pumps that deliver the liquid flows ( $m_1$  and  $m_2$ ) to Tank 1 and Tank 2. These two tanks are interconnected at the bottom through a manually controlled valve. In this work, two tank interacting process is considered as two inputs two outputs process in which level  $c_1$  in Tank1 and level  $c_2$  in Tank 2 are considered as output variables and  $m_1$  and  $m_2$  are considered as respective manipulated variables.

Both the levels  $C_1$  and  $C_2$  are sensed using a level transmitter. The level transmitter output is then given to the current to voltage converter. The output voltage is given to the DAQ ant then to the controller. The controller will take the correct action and the control signal is given to the voltage to current converter. The I/P converter converts the current to pressure and then given to the control valve. Thus the flow is regulated and hence the level is controlled.



Fig.1. Experimental setup of Two Tank interacting process

Here, Lineal Decoupling [10] is opted. The prefatory closed loop control system Block diagram of 2 X 2 systems is shown in Fig.2. In a system with interactions,  $G_{12}$  and  $G_{21}$  matrix will not be not zero, but can manipulate the controller signal such that the system appears to be partially decoupled.

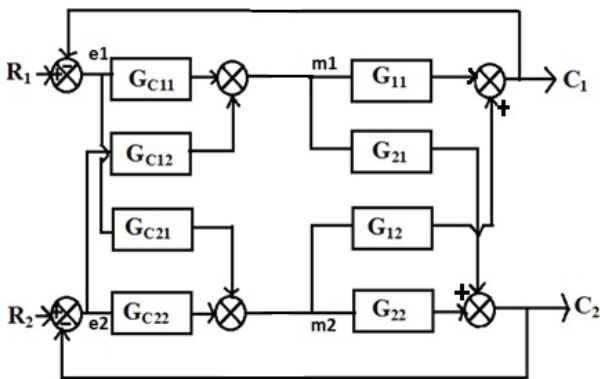

Fig.2. Closed loop block diagram of 2 X 2 systems

From the block diagram we can write,

$$c_1 = G_{11} m_1 + G_{12} m_2$$

$$c_2 = G_{21} m_1 + G_{22} m_2$$

where  $G_{11}$ ,  $G_{12}$ ,  $G_{21}$ ,  $G_{22}$  are the process transfer functions. The inputs are  $m_1$  and  $m_2$  and the outputs are  $c_1$  and  $c_2$  [9].

### III. CONTROLLER DESIGN

#### A. Design of Model Reference Adaptive Controller

Model reference adaptive system that uses Model Reference Adaptive Control (MRAC) [7] is an adaptive system that makes denotative use of such models for identification or control purposes. In MRAC, a good intellect of the plant and the performance requirements grants the designer to come up with a model, referred to as reference model that describes the desired properties of the closed loop plant.

The Model Reference Adaptive Controller is designed for a decoupled two tank interacting System ie, the controller designed is then given to the process with Decoupler.

The basic structure of the MRAC is shown in Fig.3. The reference model is selected to yield the desired trajectory,  $y_m$  that the plant output  $y$  has to follow [9]. The tracking error is generated by taking the difference between the plant output and the reference model output, establishes the digression of the plant output from the desired trajectory.

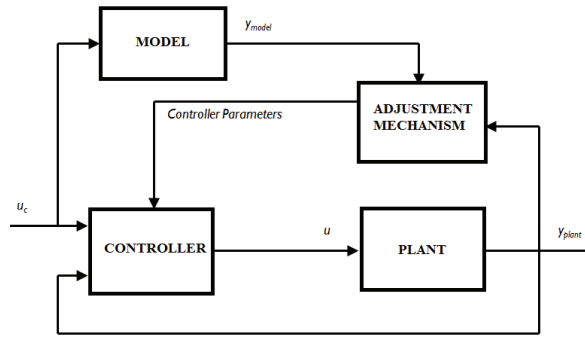

Fig.3. Block diagram of Model Reference Adaptive Control

Fig.4. shows the Block diagram of the process with Model Reference Adaptive Controller in Lab VIEW.

The closed loop plant is made up of an ordinary feedback control law that contains the plant and a controller and an adjustment mechanism that bring forth the controller parameters.

#### B. Design of an Optimised Model Reference Adaptive Controller using Genetic Algorithm

Here the tuning parameter gamma is optimised using Genetic Algorithm. The procedure for Genetic Algorithm is as follows:

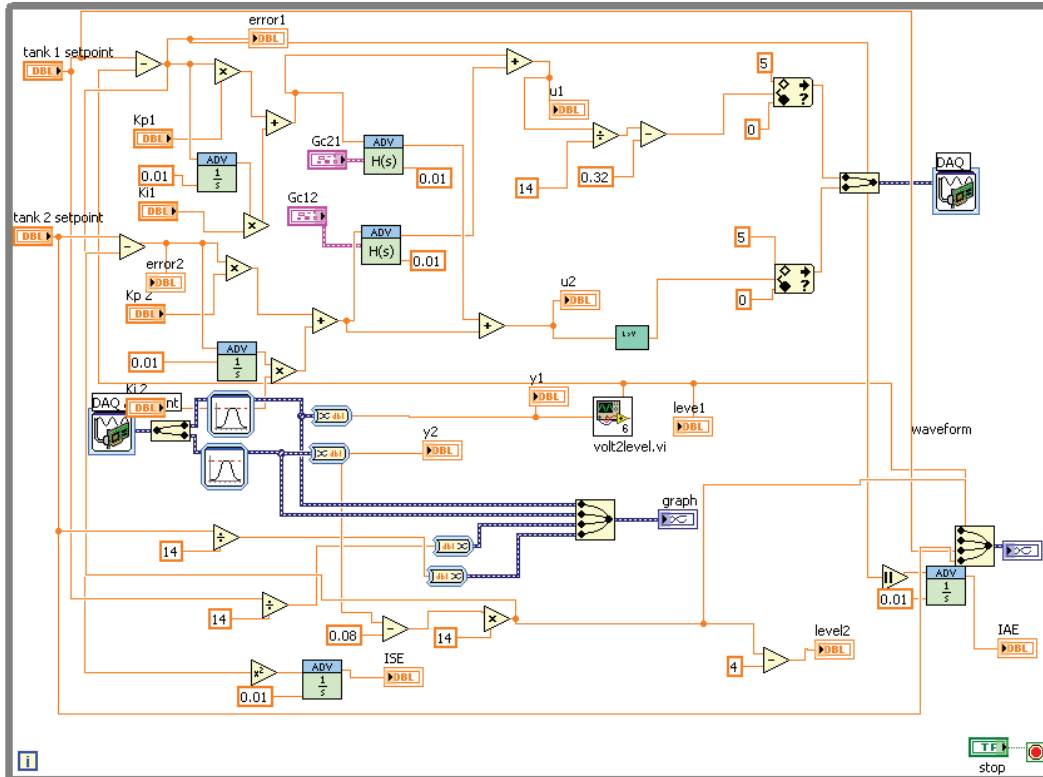

Fig.4. Block diagram of the plant with Model Reference Adaptive Control

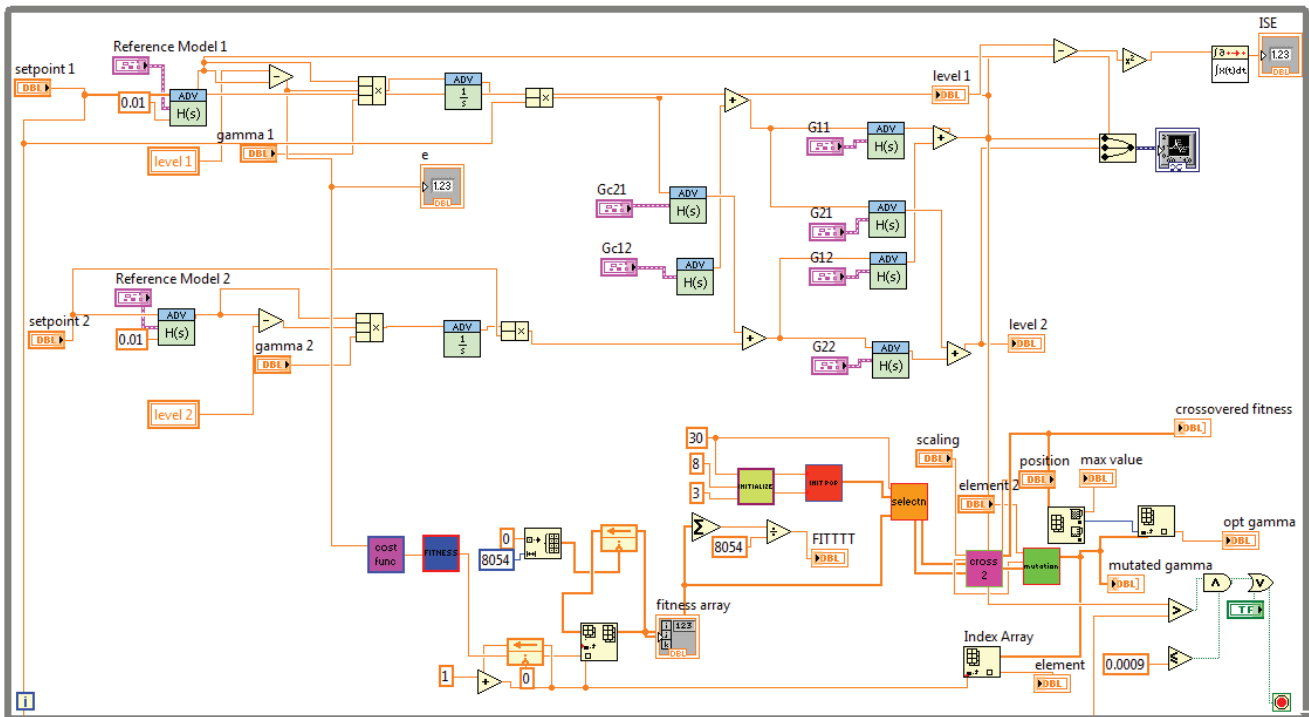

Fig.5. Block diagram of the plant with an optimised Model Reference Adaptive Control

1. Choose an population of individuals
2. Measure the fitness of each individual in that population
3. Repeat the procedure until termination
  - a. Select the best fit individuals for reproduction/selection.
  - b. The new individuals will then go through crossover and mutation process to produce new offspring.
  - c. Measure the fitness of each new individuals.
  - d. Substitute the least-fit population with new individuals.

Fig.5. shows Block diagram of the plant with optimised Model Reference Adaptive Controller in LabVIEW. This is used to obtain an optimised tuning parameter, gamma. The selection, crossover and mutation are given as subVI's.

The GA starts with a random population being initialized. This can be easily achieved in LabVIEW using the random number generator. Determining the number of population is the one of the important step in GA. It suggested that the safe population size is from 20 to 100 [1]. Here a population of 30 is used. The objective function used in this work was the cost function which is selected for MRAC i.e.  $J(\theta) = 1/2e^2(\theta)$ .

Another function that is the fitness function is usually used to transform the objective function value into a measure of relative fitness. This mapping is always needed when the objective function is to be minimized as the lower objective function values correspond to fitter individuals [12]. Most often used transformation is that of proportional fitness assignment. The fitness function, f used was:  $f = 1 / (0.01 + \text{Cost function})$

#### IV. RESULTS AND DISCUSSION

The real time results using an Optimised Model Reference Adaptive Control and conventional controller for the two tank interacting system are given as follows. The performance of the two controllers are evaluated and compared in terms of rise time and settling time. The performance index, Integral square error (ISE), Integral Absolute Error or IAE [2] is computed to demonstrate a performance comparison between the two controllers with a justification that having a lesser value of ISE and IAE means better performance [3].

Fig.6 and Fig.7 shows the response of MRAC for different setpoints and Fig.8 and Fig.9 shows the response of Optimised MRAC for different setpoints.

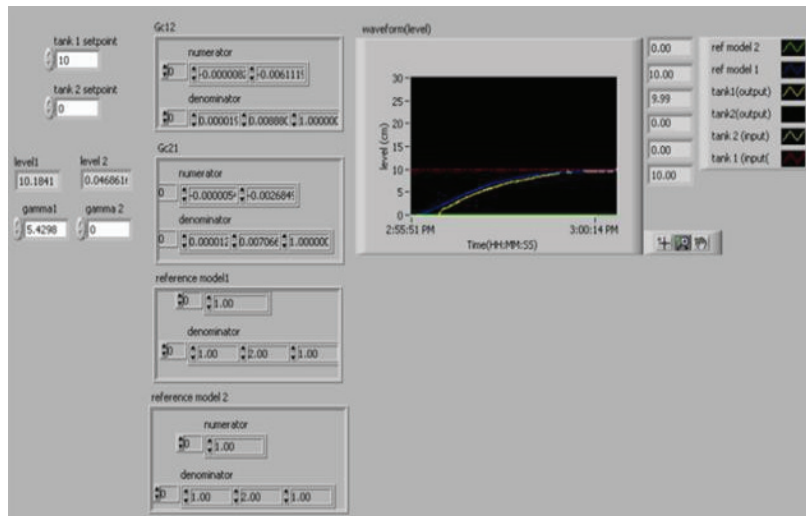

Fig.6. Response of the plant with Model Reference Adaptive Control for setpoint 10

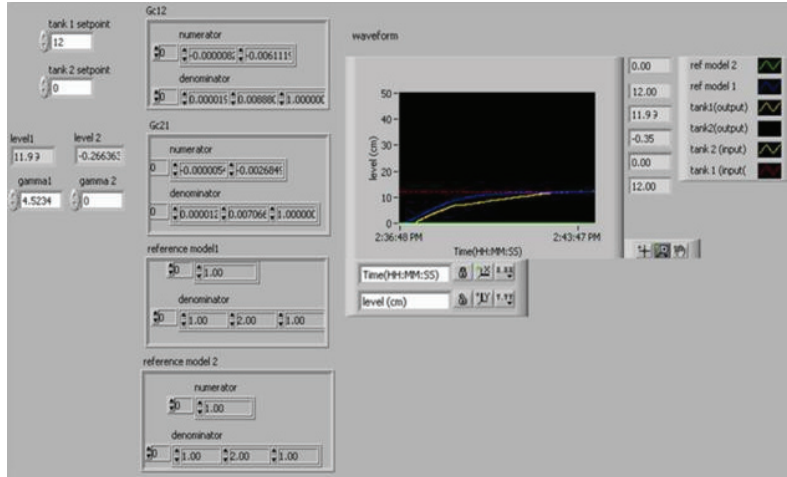

Fig.7.Response of the plant with Model Reference Adaptive Control for setpoint 12

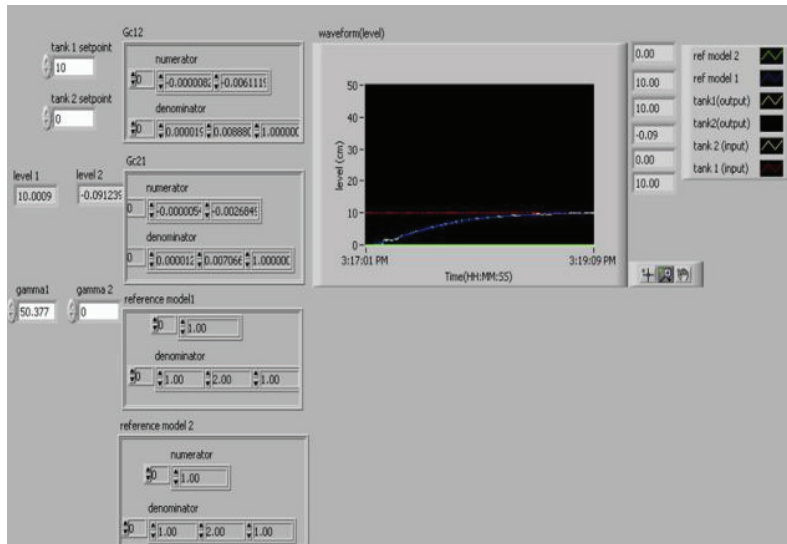

Fig.8.Response of the plant with an Optimised Model Reference Adaptive Control for setpoint 10

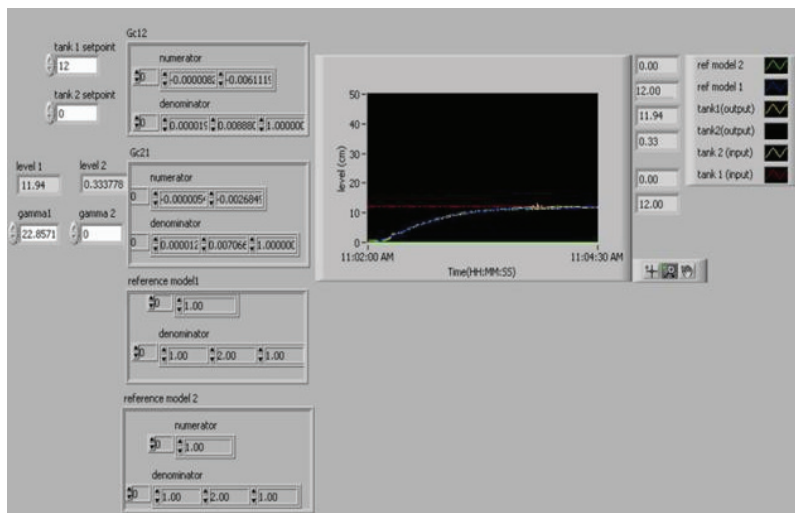

Fig.9.Response of the plant with an Optimised Model Reference Adaptive Control for setpoint 12

TABLE I PERFORMANCE CRITERIA

| CONTROLLER        | SETPOINT (cm) | RISE TIME(sec) | SETTLING TIME(sec) | INTEGRAL SQUARE ERROR (ISE) | INTEGRAL ABSOLUTE ERROR (IAE) |
|-------------------|---------------|----------------|--------------------|-----------------------------|-------------------------------|
| PI Controller     | 10            | 169            | 240                | 4466.27                     | 1038.16                       |
|                   | 12            | 97             | 185                | 8525.16                     | 1407.99                       |
| MRAC              | 10            | 99             | 143                | 1630.2                      | 984.80                        |
|                   | 12            | 75             | 150                | 1899.38                     | 1038.22                       |
| GA Optimised MRAC | 10            | 65             | 132                | 192.242                     | 160.438                       |
|                   | 12            | 65             | 136                | 208.646                     | 141.319                       |

Table I shows the performance criteria based on the responses obtained for an Optimised Model Reference Adaptive Controller, Model Reference Adaptive Controller. The Time Integral Performance Criteria such as Integral Square Error (ISE) and Integral Absolute Error (IAE), Rise time, Settling time are tabulated. The Rise time, Settling Time, ISE and IAE values are improved when an Optimised Model Reference Adaptive Controller is used.

V. CONCLUSION

In this work the design of an Optimised Model Reference Adaptive Control was done in real time using LabVIEW. The performance comparisons have been made in terms of rise time, settling time and performance criteria. From the responses it is clear that the Optimised Model Reference Adaptive Control shows a better response than other controller. That is the process is perfectly following the model. Also the settling time is much faster than the process settling time. The performance index tells that it is one fold better. An Optimised Model Reference Adaptive Control proves to be robust and achieves an excellent control performance as compared to conventional MRAC.

REFERENCES

[1] Abdul Jaleel, Abdul Nazir, Gautham, Remya Surajan, Binu.L.S, (2009) ‘A simplified Genetic Algorithm for online tuning of PID controller in LabVIEW, World Congress on Nature & Biologically Inspired Computing (NaBIC).

[2] D. Rathikarani &D. Sivakumar, October (2009) ‘Adaptive PI Controller for a Nonlinear System’, Sensors & Transducers Journal.

[3] Ivan Holic and Vojtech Vesey, (2011) ‘Robust PID Controller Design for Coupled-Tank Process’, 18th International Conference on Process Control June 14–17.

[4] Mohd Fua’ad Rahmat & Sahazati Md Rozali, (2008) ‘Modeling and Controller Design for A Coupled Tank Liquid Level System: Analysis & Comparison’ *Journal Technology*, University Technology, Malaysia, 113–141.

[5] Muhammad Nasiruddin, Mahyuddin and Mohd Rizal Arshad, (2008) ‘Performance Evaluation of Direct Model Reference Adaptive Control on a Coupled-tank Liquid Level System’, *Journal Technology*, Malaysia, 9-17.

[6] N. Farokhnia, R. Khoraminia and G.B. Gharehpetian,(2010) ‘Optimization of PI Controller Gains in Nonlinear Controller of STATCOM Using PSO and GA’, *International Conference on Renewable Energies and Power Quality Granada* (Spain).

[7] Pankaj Swarnkar, Shailendra Jain, And R.K Nema, (2010) ‘Effect of Adaptation Gain on system Performance for Model Reference Adaptive Control Scheme using MIT Rule’, *World Academy of Science, Engineering and Technology* 70.

[8] R.Prakash, R.Anita, (2010) ‘Robust Model Reference Adaptive PI Control’ *Journal of Theoretical and Applied Information Technology*.

[9] Astrom, K.J. and Wittenmark.B, (2002) ‘Adaptive Control’, *Second Edition*, Englewood Cliff, NJ: Prentice Hall. 187-222.

[10] Deshpande.B, (1989) ‘Multivariable process Control’, Instrument Society of America.

[11] George Stephanopoulos, (1984) ‘Chemical Process Control an Introduction to Theory and Practice’, Prentice Hall, Englewood Cliffs, New Jersey, 486-504.

[12] Pedro Ponce-Cruz Fernando& D. Ramirez-Figueroa, (2010) ‘Intelligent Control Systems with LabVIEW’, *Springer London Dordrecht Heidelberg*, New York.