

Simulation of IGBT Based Cyclo-Inverter Run Induction Motor

Sudhin Govind and Jiku Thomas

PG Scholars, Karunya University, Coimboore - 641 114, Tamil Nadu, India

Email : sudhinpr@gmail.com

(Received on 21 February 2013 and accepted on 24 April 2013)

Abstract - This paper introduces a new technique for converting power at supply frequency to a higher frequency, using a cyclo-inverter circuit, where IGBT is used as the switching element. This circuit is used in induction heating, ballast, high frequency supplies and in high speed induction motors. The control circuit developed for the cyclo-inverter supplies trigger signals for the IGBT for developing power at any frequency which is an integer multiple of supply frequency. The high frequency power is then used to run a single phase capacitor start induction motor for developing high speeds. The working of the proposed system was verified by observing waveforms on CRO and was found to be satisfactory.

Keywords: MATLAB, Cyclo-converter, Induction motor

I. INTRODUCTION

Rapid developments in the field of power electronics has led to the availability of a wide range of inverter circuits, varying in output frequency and voltage. The origin of such circuits is the single phase bridge inverter circuit, but its output is not sinusoidal and contains harmonics. Hence, resonant inverters are used where the frequency is much higher, at around 100 KHz, with high efficiency but since the switch carries the load current for a longer period, the device rating has to be higher.

Variable voltage and variable frequency ac motor drives have come to increased use in various industrial applications. These new approaches need a simple method of control for ac motors.

A cyclo-inverter is a type of power control in which an alternating voltage at supply frequency is converted directly to an alternating voltage at load frequency without any intermediate d.c stage. The cyclo-inverter is controlled by controlling the firing pulses so that it produces an alternating output voltage. By controlling the frequency and depth of phase modulation of the firing angles of the converters, it is possible to control the frequency and amplitude of the

output voltage. Thus, a cyclo-inverter has the facility for continuous and independent control over both its output frequency and voltage. The quality of output voltage wave and its harmonic distortion also impose the restriction on this frequency. The distortion is very low at low output frequency.

Here, a cyclo-inverter is suggested where the IGBT switch is self commutated and hence eliminates the need for a commutation circuit. The proposed cyclo-inverter is then used to power a capacitor start induction motor and its performance is simulated in MATLAB.

II. PROPOSED CONVERTER

The figure 1 below shows the detailed circuit of the proposed converter. It consists of a single phase transformer with mid tap on the secondary winding and four thyristors, without any flow of circulating current. Two of these thyristors P1,P2 are for positive group and the other two are for negative group. Load is connected between secondary winding and terminal A as shown. Output is obtained through proper conduction of IGBTs in the two input cycles. The IGBTs are fired according to a cycle depending on the integer multiple with which the supply frequency is to be multiplied. Thus, the output of converter will have a frequency, $f_o = f_i \times N_r$ where N_r is an integer and f_i is the source frequency.

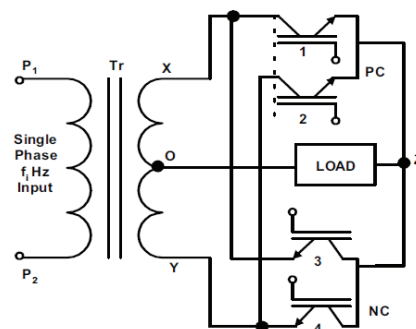

Fig.1 mid-point cyclo-inverter

III. CAPACITOR START INDUCTION MOTOR

In a split phase rotating field induction motor, the phase difference between start and run winding currents fall far short of 90 degrees. The starting torque developed in a motor that uses a split-phase stator also falls far short of the maximum that can be attained at an ideal 90 degree phase difference.

A phase shift closer to the ideal 90 degrees is possible through the capacitor-start system for creating a rotating stator field. This system, a modification of the split-phase system, uses a low reactance capacitor placed in series with the start winding of the stator to provide a phase shift of approximately 90 degrees for the start current. This results in greatly improved starting torque over the standard split-phase system. Capacitor start motors have the same running characteristics as their split phase counterparts.

Since the two stator windings, the main and auxiliary coil, hav different number of turns, they will yield different mutual reactances. Therefore, a transformation is made to transfer the auxiliary winding to and equivalent winding with the same number of turns as that of the main coil. The new variables referred to the equivalent coil are given as follows

The voltage equation of the motor can be written in the d-q stationary frame as

$$\begin{aligned} \hat{V}_{sd} &= r_{sd} \cdot \hat{i}_{sd} + \frac{1}{\omega_0} \hat{\psi}_{sd} + \hat{V}_c \\ \hat{V}_{sq} &= r_{sq} \cdot \hat{i}_{sq} + \frac{1}{\omega_0} \hat{\psi}_{sq} \\ 0 &= r_r \cdot \hat{i}_{rd} + \frac{1}{\omega_0} \hat{\psi}_{rd} + \frac{\omega_r}{\omega_0} \hat{\psi}_{rq} \\ 0 &= r_r \cdot \hat{i}_{rq} + \frac{1}{\omega_0} \hat{\psi}_{rq} - \frac{\omega_r}{\omega_0} \hat{\psi}_{rd} \\ \hat{V}_c &= \omega_0 \cdot X_c \cdot \hat{i}_{sd} \end{aligned}$$

The torque and speed are governed by the equations

$$\begin{aligned} T_e &= \frac{P}{2\omega_0} (\hat{\psi}_{sd} \cdot \hat{i}_{sq} - \hat{\psi}_{sq} \cdot \hat{i}_{sd}) \\ \hat{\omega}_m &= \frac{P}{2j} (T_e - T_L - T_{damp}) \end{aligned}$$

where:

$\hat{\psi}_{sd}, \hat{\psi}_{sq}, \hat{\psi}_{rd}, \hat{\psi}_{rq}$ are the d-q- stator and rotor flux linkage, respectively.

σ_s Is the d-axis stator leakage reactanc.

r_r Is the rotor resistance;

R_r Are the rotor resistance;

ω_b Is the base speed, 314 rad/sec;

ω_r Is the rotor speed, electric rad/sec;

T_e Is the developed torque;

T_L Is the load torque;

T_{damp} Is the damping torque;

p Is the number of poles.

IV. SIMULATION RESULTS

Let X1 represents the pulses at a frequency of 50 Hz and X2 of 150 Hz. Then ANDing of X1 and X2 will result the pulses required by the IGBT T1. Further if this X2 is inverted by a NOT gate, then the ANDing of X1 and X2' will result the pulses required by the IGBT T4. Similarly, ANDing of X1' and X2 result the pulses required by IGBT T2 and then ANDing the X1' and X2' finally generates the required pulses required for IGBT T3.

The pulses produced by the pulse wave generator circuit are usually at low power level. They may not be able to trigger the devices into conduction if fed directly. These pulses are therefore boosted to high power level by acircuit known as driver circuit.

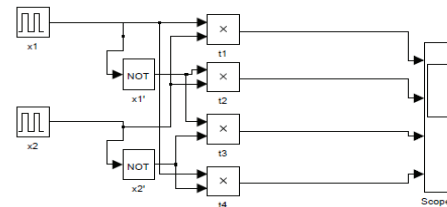

Fig. 2 trigger circuit

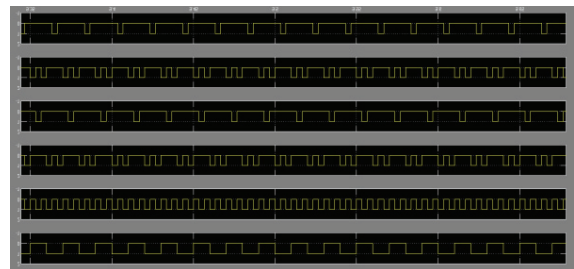

Fig.3 Trigger pulses for IGBTs

V. MATLAB SIMULATION OF IGBT BASED CYCLO-INVERTER

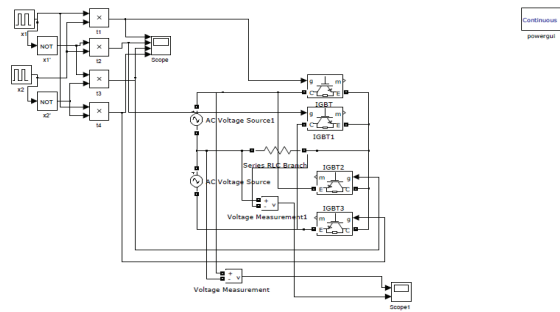

Fig.4 cyclo-inverter circuit

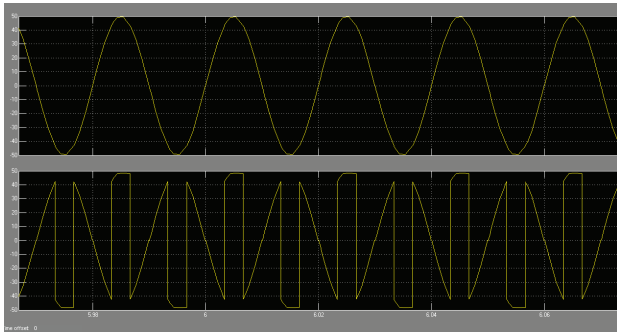

Fig.5 Input and output wave form of cyclo-inverter

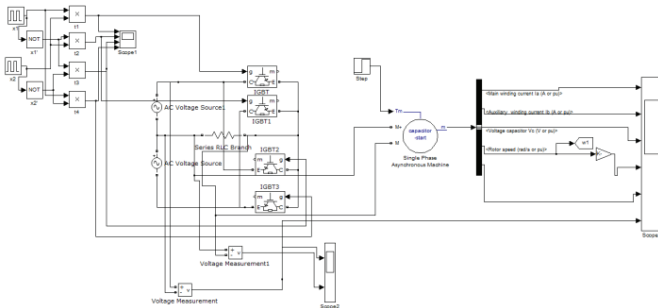

Fig.6 IGBT Based cyclo-converter run induction motor

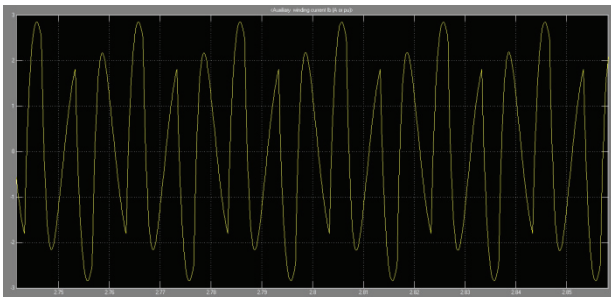

Fig.7 Axillary current

VI. CONCLUSION

The cyclo-inverter circuit was designed and simulated and desired results are obtained. A single phase cyclo-inverter was used for controlling a capacitor start single phase induction motor to generate torque characteristics that matches with demand torque characteristics. This different

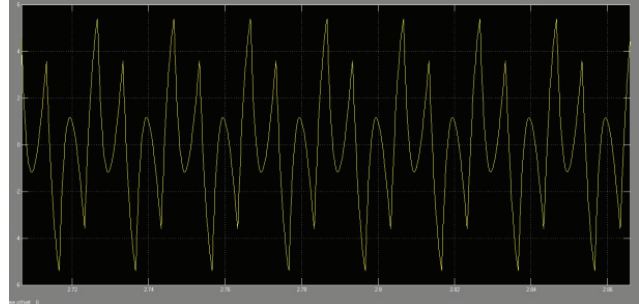

Fig.8 Main current

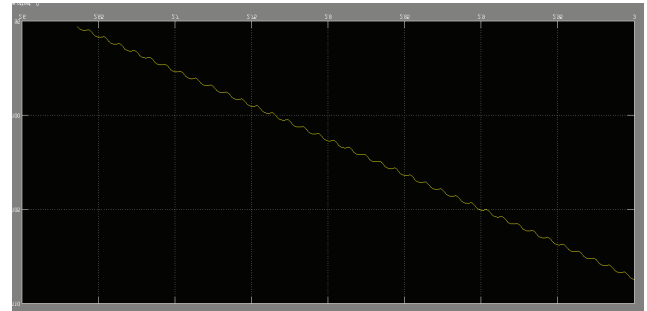

Fig.9 Speed

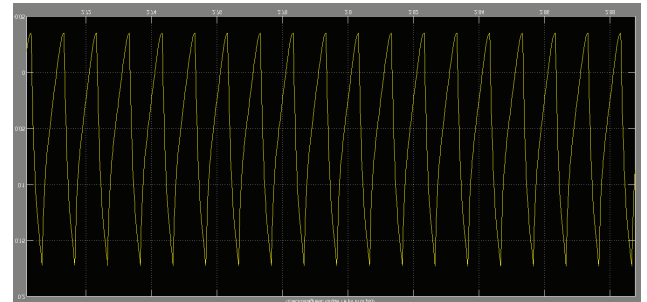

Fig.10 Torque

frequency of cycloconverter is also useful to replace flywheel from the operating machine which reduces the cause of torsional vibration and fatigue damage of machine.

REFERENCES

- [1] J. Zhang, G.P. Hunter, V.S. Ramsden, "A Single Phase Input Cyclo converter Driving a Three Phase Motor", *The European Power Electronics Association*, pp. 128-132, 1993.
- [2] Jonathan M. Gilliom, "Simulation and performance of a high frequency cyclo converter". MS thesis June 2006
- [3] Sandeep Pande and Hashit Dalvi "Simulation Of Cycloconverter Based Three Phase Induction Motor", *IJAET* July 2011.
- [4] Vineeta Agarwal and Peeyush Agarwal, "IGBT Based Cyclo-Inverter", *Asian Power Electronics Journal*, Vol. 2, No. 1, Apr 2008.
- [5] V. Ambrozic, M. Bertoluzzo, G. S. Buja, and R. Menis, "An assessment of the inverter switching characteristics in DTC induction motor drives", *IEEE Transactions on Power Electronics*, Vol. 20, No. 2, pp. 457 – 465, Mar 2005.
- [6] Abhishek, Pratap Singh and V.K. Giri, "Simulation Of Cycloconverter Fed Split Phase Induction Motor", *International Journal of Engineering Science and Technology (IJEST)*.