

Study on Load Profiling and Energy Management Systems

C.V. Aravind¹, * Norhisam², PRP Hoole¹, K.Pirapaharan¹, John Wiselin²

¹Taylor's University Malaysia, ²University Putra Malaysia, Malaysia

³Bharath University, Chennai, Tamil Nadu, India

E-mail: *aravindcv@ieee.org

(Received on 25 August 2012 and accepted on 05 November 2012)

Abstract - Energy Management System plays a very important role in the load profiling and towards the efficient organizational electrical load factor. This involves the energy auditing which is a crucial activity energy monitoring and analysis. Based on the load factor a system is modeled using commercially viable software and a system of conventional and renewable energy is proposed to improve the efficiency of the system under investigations.

Keywords: Energy Saving, Building, Energy Management System, Load Profiling, Optimization

I. INTRODUCTION

With an increase in the demand of electrical energy with the increase in the convenience mankind for household and buildings as heating, cooling and lighting the conservation of energy is crucial. The HVAC system and commercial usage significantly contribute much of electrical energy consumption. This emphasizes the importance for energy efficient operations and consumption for equipment for viable energy conservation solution. An energy efficient environment can be achieved by continuous monitoring and measurement with energy monitoring and management systems. A typical energy management embraces the data monitoring component through acquisition and analysis tool for understanding the consumption of energy over a specific period of time. Data acquisition systems with real time report generation capabilities can be realized with advanced data communication systems [1]. This work is mocked for a possible design and sizing of a complete PV system (either grid connected or standalone). This study is limited to the UCNW in Malaysia, but the evaluation approach can be applied to other systems. Under the 8th and the 9th national strategy the Malaysian government has proposed significant allocation for the use of renewable energy technology to sustain and address to the global demand on the energy. Solar Photovoltaic (PV) system is visualized as a potential resource considering the geographical location of the country. The solar radiation for the reference building is located at the (Latitude 3° 08'62"N) 3° 59'N and (Longitude 101° 74'11" E) 101° 59' E in Year 2011 is as shown in Fig.1. In this investigation the

objective for the use of photovoltaic studies is based on the cost effectiveness of feed-in tariff that results in efforts to offset the electricity consumption rate during the day time thereby increasing energy savings and management system. The scope of this work is to be able to design a graphical user interface for Energy Management system using HOMER[®] and PSCAD[®]. Fig.2 shows the power consumed in a typical load cycle.

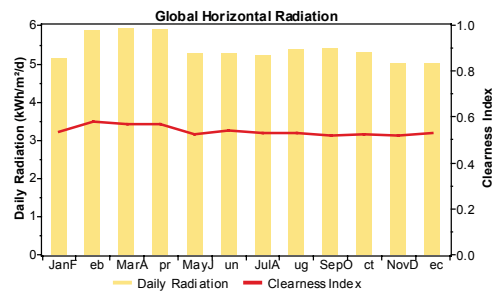

Fig. 1 Annual solar radiation tabulation for UCNW [2]

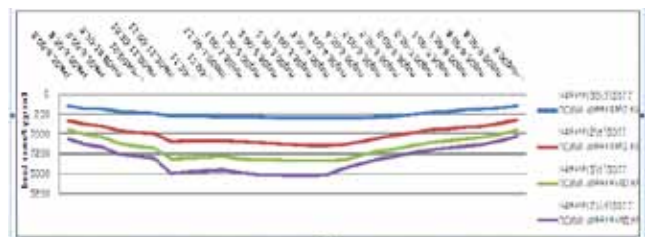

Fig. 2 24 Hourly Power (kW) Load Data Profile on 11kV/110V on March 30, April 2, 5, 17, 2011 (30 min interval)

II. SYSTEM DESIGN AND OVERVIEW

In this work HOMER[®] is used to for the Optimization of the energy system. PSCAD[®] is used to design the PV/ Grid energy management system, and to evaluate the filter design and harmonic analysis, optimal design of controller parameters, to investigate the circuit and control concepts and to investigate the pulsing effects of solar PV panel shading on electricity networks. The proposed Hybrid Renewable Energy System (HRES) consist of generators, batteries, and solar panel (PV) is as in Fig. 3. Various modeling techniques are developed by researchers to model components of HRES

for energy managements [4-5]. Similar to the above the HRES for energy management is developed.

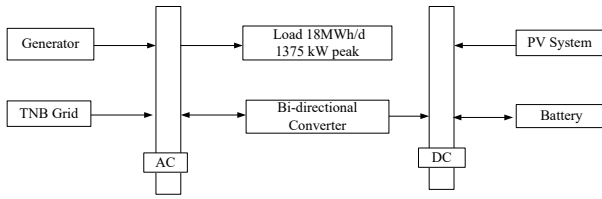

Fig. 3 Overview of the possible Hybrid Renewable Energy System (HRES)

Figure 4 shows the flowchart representation on the operational strategy for the HRES. After the data is received, the calculations are performed before retrieving back the optimized data and sensitivity analysis results. Fig.5 shows the CAD model developed for the proposed. As can be seen the PV module is designed based on the built-in incremental conductance algorithm as in Fig.6. Fig 7 and Fig.8 shows the built in model of PV/grid system proposed inside the energy management system. Table I shows the possibility proposal for the investigated center for economic viability.

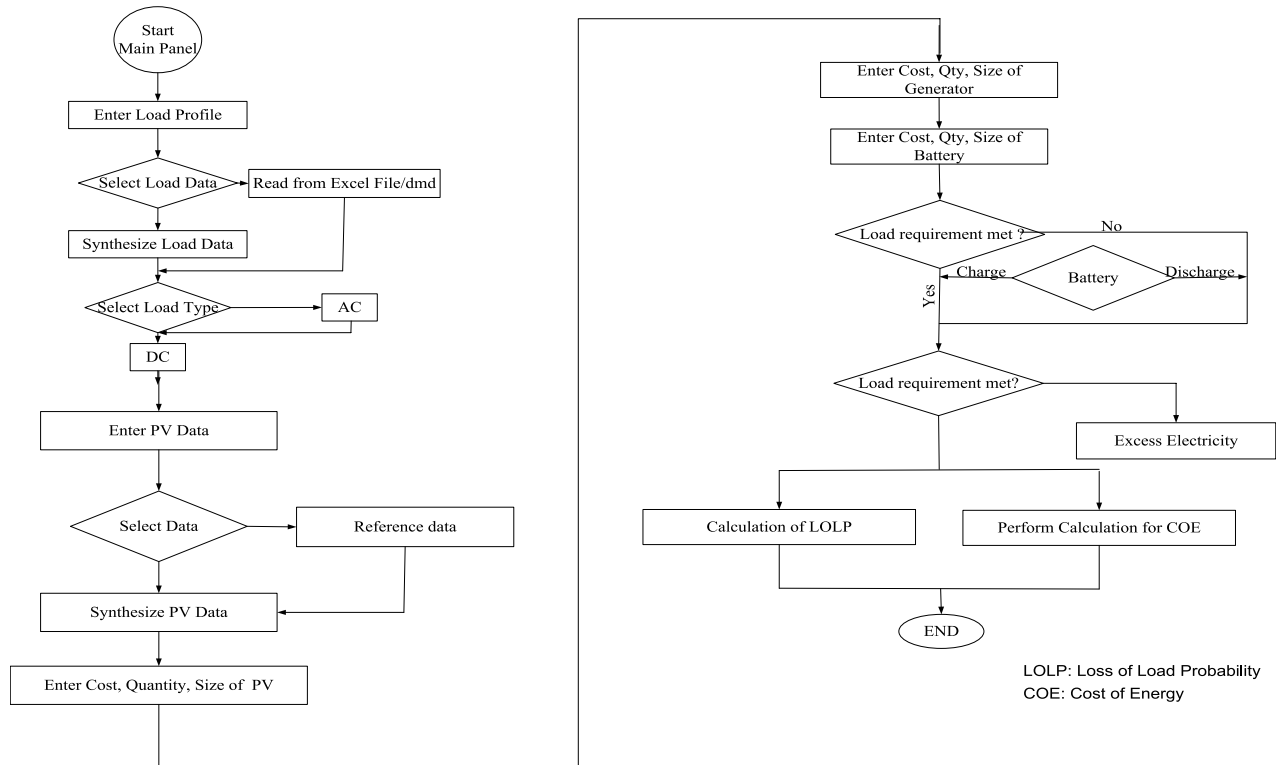

Fig. 4 Overview of the possible Hybrid Renewable Energy System configuration (PV/TNB)

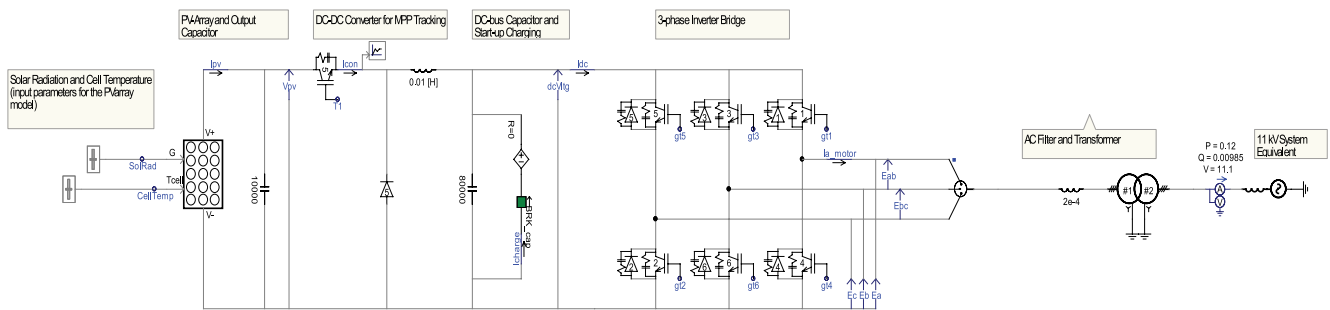

Fig. 5 CAD model of the proposed Hybrid Renewable Energy System configuration (PV/TNB) [6]

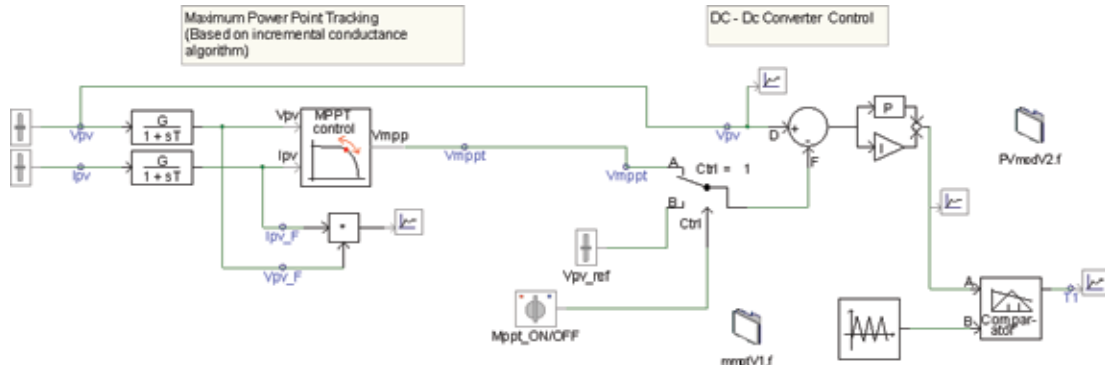

Fig. 6 Incremental conductance algorithm implemented proposed HRES using PSCAD (PV/TNB) [6,7]

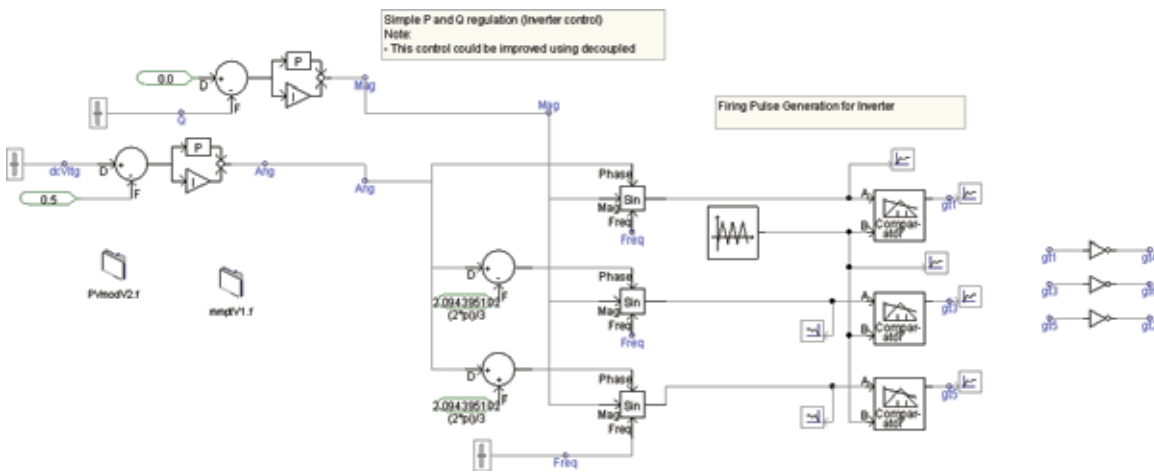

Fig. 7 PSCAD software proposed modeled PV/Grid System

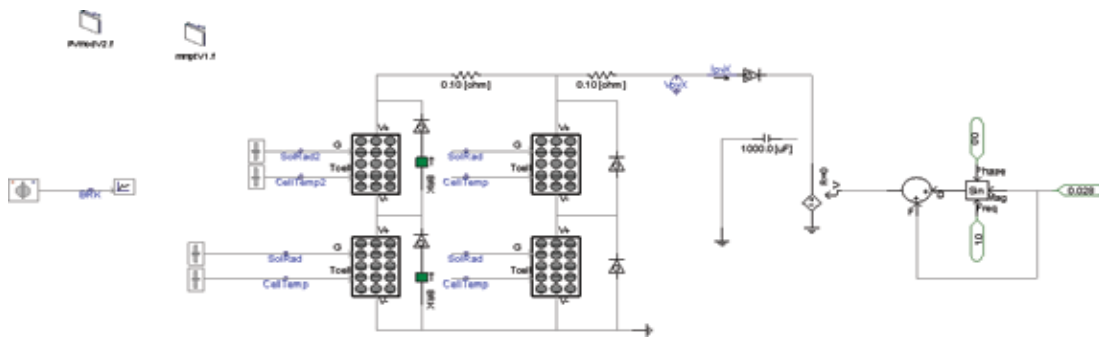

Fig. 8 PSCAD software proposed modeled PV Shading System

TABLE I SUMMARY OF THE FOUR PROPOSED OPTIMAL HRES SYSTEM IN HOMER®

	Optimum system (Case 1) 5882 kWh/day	Optimum system (Case. 1) 6113 kWh/day	Optimum system (Case 1) 6160 kWh/day	
Sizing of conventional generators (kW)	20	20	20	
Sizing of renewable energy components (PV Panel)(kW)	9	100.8	190	
Size of converter	5	31	31	
Number of batteries	0	0	0	
	Optimum system (Case 2) 5882 kWh/day	Optimum system (Case 2) 6113 kWh/day	Optimum system (Case 2) 6160 kWh/day	
Sizing of conventional generators (kW)	20	20	20	
Sizing of renewable energy components (PV Panel)(kW)	9	100.8	190	
Size of converter	5	31	31	
Number of batteries	32	32	32	
	Optimum system (Case 3) 5882 kWh/day	Optimum system (Case 3) 6113 kWh/day	Optimum system (Case 3) 6160 kWh/day	System with derating factor of 0.7895 (5800 kWh/day)
Sizing of conventional generators (kW)	20	20	20	0
Sizing of renewable energy components (PV Panel)(kW)	21	190	190	9
Size of converter	5	31	31	1
Number of batteries	0	0	64	0

A. Energy Analysis

To effectively produce an energy management system, simulating the energy yield and cost analysis are carried out. This is done by pointing out the different energy using system in the building and their operation with the Load Factor been put into consideration (must be close to 1 as much as possible). An energy using system that consumes a continuous amount of energy all year round and the seasonal loads (HVAC system consumption) which mostly due the variations in weather, season, operation of the building like school season etc. The trends in energy consumption including the watching the ups and down and the movement of the energy usage trend in kWh, demand, natural gas or cost. The 12 month rolling method using graphical analysis of a 12-month period of the energy usage system of the building. An efficient energy management system must comprise of energy auditing, monitoring and management with the capabilities of scheduling, duty cycling, demand limiting, optimal is starting, monitoring and direct digital control. For this project, data were acquired from the metering console.

B. Economical Study

In this study, an estimated cost for PV system implementation is being predicted using HOMER software. The estimated cost is including the capital cost, replacement cost, operation and maintenance cost and salvages cost for each component of the system. Fig. 9 shows the cost summary of the components in the solar-pv tariff system. Fig.10 shows the return of investment for a period of 25 years. Fig.11 shows the electricity expenditure during the

period of investigations. Fig. 12 shows the expenditure with implementing the proposed PV/grid system. Fig. 13 shows the optimized output for the case of the 5882kWh/day.

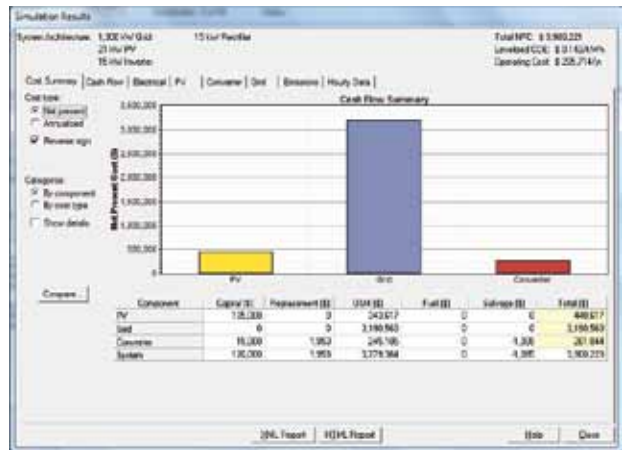

Fig. 9 Economics of each component in the PV Tariff System for the 5882kWh / day

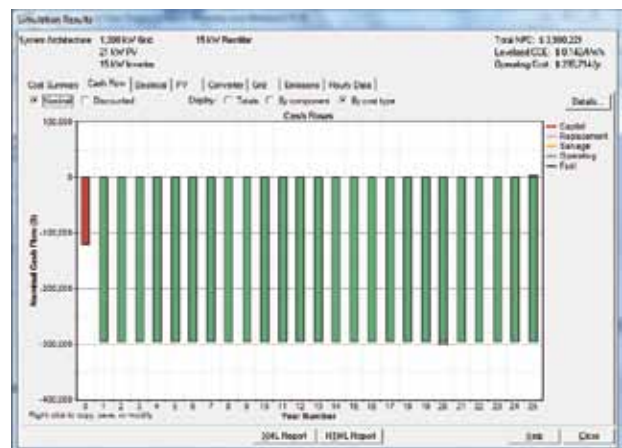

Fig. 10 Cash Flows in 25 Years

III. CONCLUSION

The proposed design Energy Management System show an appropriate type of power system to be designed, components to include in the design, size, available type of energy resource that are cost effective, and type of energy balance calculation for the system performance. The objectives of the investigations are being achieved through a justified validation using experimental and simulation results in real time and the system was modeled using PSCAD®. The optimized output for the case of the 5882kWh/day shows the economic viability in saving costs towards the plant operation.

ACKNOWLEDGMENT

The author wishes to credit the work done by the student Daniel Ekine in building the system.

REFERENCE

- [1] P. E. Albert Thumann, C. E. M and William J. Younger, C. E. M. Handbook of Energy Audits (7th Edition), pp. 32 -315, 2008.
- [2] WCE 2010, London, U. K; (System Design and Cost Analysis Simulation of Small Dual-Tariff Solar Photovoltaic (PV) System in UiTM Pulau Pinang Malaysia, June 30 – July 2, 2010.
- [3] Peter Lilienthal, “HOMER Energy – Hybrid Renewable & Distributed Power Design Support, Energy Modeling Software for Hybrid Renewable Energy Systems,”
- [4] A. D. Rajapakse, D. Muthumuni, N. Perera, and K. Strunz, “Electromagnetic Transients Simulation for Renewable Energy Integration Studies,” *Proceedings of IEEE PES Annual Meeting, Tampa, FL, USA*, pp. 24–28, June 2007.
- [5] Eyad S. Hrayshat “Techno-economic Analysis of Autonomous Hybrid Photovoltaic-Diesel-Battery System,” Jordan, *Elsevier- Energy For Sustainable Development*, 28 July 2009.
- [6] Warsono, DJ. King, C. S. Ozveren and D. A. Bradley, “Economic Load Dispatch Optimization of Renewable Energy in Power System Using Genetic Algorithm,” *Power tech07*, April 2007.

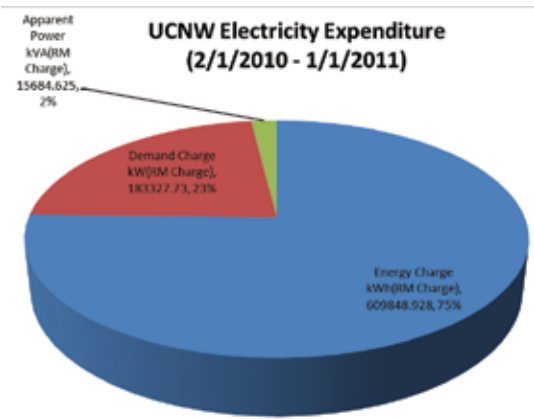

Fig. 11 Effect of electricity expense without a PV/Grid system

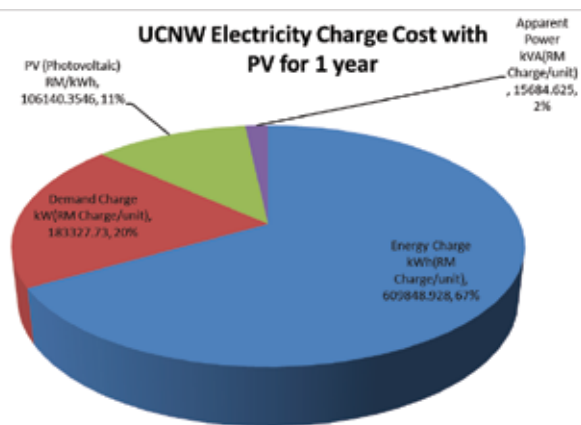

Fig. 12 Effect of electricity expense with a PV/Grid system

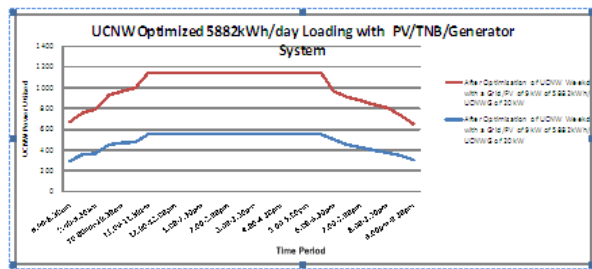

Fig. 13 Optimized Output for the possible optimum system of (5882 kWh/day)